

**INSULATING FLANGE PLAN**

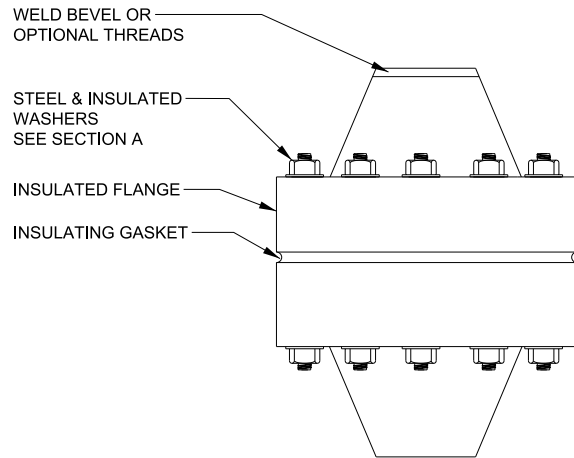

**INSULATING FLANGE PROFILE**

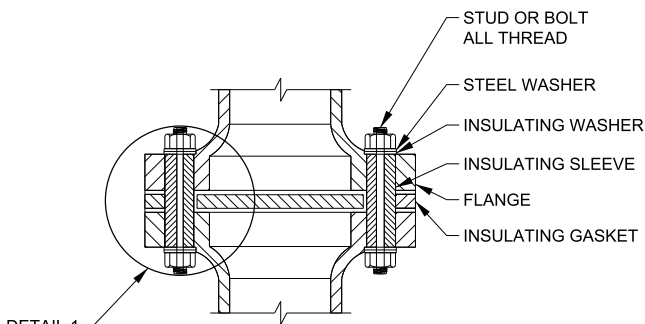

**SECTION A-A**

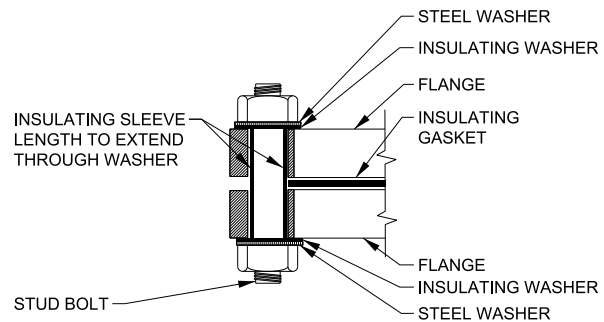

**DETAIL 1**

**NOTE**

1. PROVIDE FITTINGS & INSULATING COMPONENTS SUITABLE FOR PRESSURES, TEMPERATURES & MATERIALS WITHIN & ADJACENT TO THE PIPE. ALL FITTINGS POTABLE WATER SHALL BE NSF 61 CERTIFIED.
2. INSULATED FITTINGS SHALL BE SIZED SO AS NOT TO RESTRICT FLOW CHARACTERISTICS.
3. INSULATED FLANGE TO BE SELECTED FROM THE APPROVED PRODUCT LIST.



**PUBLIC WORKS  
STANDARD DRAWING**

REV. DATE: FEBRUARY 2015

APPROVED BY

**WT**

STD. DWG. NUMBER

**3-2-6**

DRAWN BY

**AECOM**

SCALE

**N.T.S.**

**INSULATING FLANGE**