

TYPICAL SECTION
AIR VALVE

NOTES:

1. ALL WASTE WATER AIR VALVES TO BE STAINLESS STEEL WITH MINIMUM 50mm INLET.
2. ALL ALL THREADED PIPE, FITTINGS, VALVES AND APPURTENANCES MUST BE STAINLESS STEEL 316L SCHEDULE 40 TO ASTM A776.
3. WASTE WATER FORCEMAIN DIAMETER, MATERIAL, VALVE CHAMBER SIZES PER LINEAR STANDARD DESIGN.
4. ALL PIPING, FITTINGS, VALVES AND APPURTENANCES TO BE c/w DENSO PASTE, DENSO MASTIC AND DENSO TAPE OR APPROVED EQUAL, APPLIED TO MANUFACTURER'S RECOMMENDATIONS.
5. PROVIDE FLANGED TEE TO EQUAL SIZE OF FORCEMAIN AND MIN. 200mm FOR FORCEMAINS LARGER THAN 200mm.

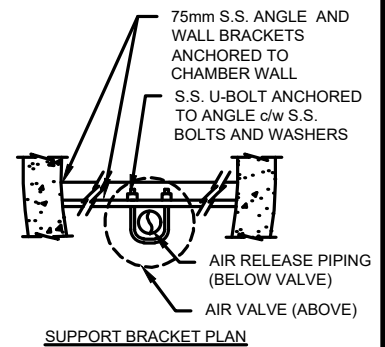

SUPPORT BRACKET PLAN



PUBLIC WORKS
STANDARD DRAWING

REV. DATE: APRIL 2021

APPROVED BY
MNB

DRAWN BY
GM BluePlan

SEWAGE PUMPING STATION
AIR VALVE DETAIL

STD. DWG. NUMBER
SPS-113

SCALE
Not to Scale