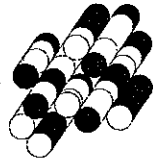


**Appendix U**  
**Geotechnical and Pavement Assessment**

**Appendix U.1**  
**Geotechnical and Pavement Assessment**  
**for Mississauga Road/Old Main Street**  
**and Bush Street**



# Terraprobe

Consulting Geotechnical & Environmental Engineering  
Construction Materials Inspection & Testing

DRAFT

## PRELIMINARY PAVEMENT DESIGN REPORT

BUSH STREET (RR 11) AND MISSISSAUGA ROAD (RR 1)

FROM WINSTON CHURCHILL BOULEVARD TO OLDE BASE LINE ROAD

REGIONAL MUNICIPALITY OF PEEL, ONTARIO

**PREPARED FOR:** Region of Peel  
9445 Airport Road, 3<sup>rd</sup> Floor  
Brampton, Ontario  
L6S 4J3

File No. 1-10-5056  
August 06, 2010

**Terraprobe Inc.**  
10 Bram Court  
Brampton, Ontario  
L6W 3R6  
Phone: (905) 796 2650  
Fax: (905) 796 2250

**Distribution:**

1 Copy - Region of Peel  
1 Copy - Dillon Consulting Limited  
1 Copy - Terraprobe Inc., Brampton

---

**Terraprobe Inc.**

**Greater Toronto**  
10 Bram Court  
Brampton, Ontario L6W 3R6  
(905) 796-2650 Fax 796-2250  
brampton@terraprobe.ca

**Hamilton - Niagara**  
903 Barton Street, Unit 22  
Stoney Creek, Ontario L8E 5P5  
(905) 643-7560 Fax 643-7559  
stoneycreek@terraprobe.ca

**Central Ontario**  
220 Bayview Drive, Unit 25  
Barrie, Ontario L4N 4Y8  
(705) 739-8355 Fax 739-8369  
barrie@terraprobe.ca

**Northern Ontario**  
1012 Kelly Lake Rd.  
Sudbury, Ontario P3E 5P4  
(705) 670-0460 Fax 670-0558  
sudbury@terraprobe.ca

[www.terraprobe.ca](http://www.terraprobe.ca)

## TABLE OF CONTENTS

1	GENERAL DATA .....	1
1.1	Background & History .....	1
1.2	Terms of Reference .....	1
1.3	Project Limits .....	1
2	DESIGN CRITERIA .....	2
2.1	Traffic Volumes .....	2
3	PAVEMENT PERFORMANCE (EXISTING CONDITION).....	2
4	PHYSIOGRAPHY .....	3
5	FIELD INVESTIGATIONS AND LABORATORY TESTING .....	3
5.1	Field Work .....	3
5.2	Laboratory Testing.....	5
6	SOIL AND PAVEMENT DATA.....	5
6.1	Subgrade Soils .....	5
6.1.1	Mississauga Road .....	5
6.1.2	Bush Street.....	7
6.2	Groundwater Conditions .....	8
6.3	Bedrock .....	8
7	BORROW MATERIALS .....	8
8	AGGREGATE/GRANULAR MATERIALS .....	9
9	ALIGNMENT AND GRADELINE .....	9
10	PAVEMENT DESIGNS .....	9
10.1	Design Parameters.....	10
10.2	Mississauga Road .....	10
10.3	Bush Street .....	11
11	RECOMMENDATIONS AND CONSTRUCTION FEATURES.....	12
11.1	Pavement Structure (Material Types) .....	12
11.2	Padding .....	12
11.3	Asphalt Cement Grade .....	12
11.4	Tack Coat.....	12
11.5	Pavement Tapers .....	13
12	CUT MATERIALS AND DESIGN .....	13
13	EMBANKMENT MATERIALS AND DESIGN.....	13
14	DRAINAGE .....	13
14.1	Culvert Bedding, Cover and Backfill .....	13
14.2	Ditches .....	14
15	OTHER DESIGN FEATURES.....	14



15.1	Compaction .....	14
15.2	Excavations .....	14
15.3	Frost Penetration .....	15
15.4	Soil Disposition .....	15
16	LIMITATIONS AND RISK .....	16
16.1	Procedures .....	16
16.2	Changes in Site and Scope .....	16

### Figures

Key Plan	Figure 1
Site Photographs	Figures 2A to 2C
Borehole Location Plans	Figures 3 to 17

### Appendices

Appendix A	Record of Borehole Sheets and Granular Thickness Data
Appendix B	Pavement Condition Evaluation Forms
Appendix C	Pavement Core Data and Photographs
Appendix D	Laboratory Test Results
Appendix E	Subdrain Details
Appendix F	Certificates of Chemical Analysis
Appendix G	Falling Weight Deflectometer (FWD) Reports



## **1 GENERAL DATA**

### **1.1 Background & History**

Mississauga Road (Regional Road 1) is a north-south oriented two lane rural arterial roadway within the project limits. Bush Street (Regional Road 11) is a two-lane east-west oriented rural arterial road that passes through the Hamlet of Belfountain. A Schedule 'C' Municipal Class Environmental Assessment is required for the rehabilitation/reconstruction of both roadways. This study will also identify existing problems and opportunities for improvement.

Some of the key pavement related issues to be addressed as part of this study are:

- Deteriorating pavements.
- Structural and drainage deficiencies along study corridor.
- Insufficient shoulders necessitating pavement widening.
- Inadequate stopping sight lines necessitating modifications to the existing grade profile.

### **1.2 Terms of Reference**

Terraprobe carried out the investigation and preliminary design for this project as a sub-consultant to the Region of Peel.

This study includes the following main project components.

- Rehabilitation/reconstruction of the existing roadway platform.
- Improvements to the existing profile and road width to conform to current transportation standards.

### **1.3 Project Limits**

The west limit of Bush Street is Sta. -0+044 approximately 44 m west of the north leg of Winston Churchill Boulevard and the east limit is Old Main Street, Sta. 2+070 i.e. a total distance of about 2,114 m.

The project length on Mississauga Road is approximately 6,130 m and extends from Sta. 36+900 (south limit) to Sta. 43+030 (north limit).

The site location is depicted on the key plan in Figure 1 and site photographs of the roadway are included in Figures 2A, 2B and 2C.



## 2 DESIGN CRITERIA

### 2.1 Traffic Volumes

The traffic data for this project was provided by the Region of Peel. This data is summarized in the following table:

Parameter	Mississauga Road	Bush Street
AADT (2009)	3,266	2,640
Projected AADT (2011)	3,400	2,695
Projected AADT (2026)	4,575	3,130
Projected AADT (2031)	5,050	3,290
Annual Growth Rate	2%	1%
Percent Commercial	5%	2%

## 3 PAVEMENT PERFORMANCE (EXISTING CONDITION)

Visual pavement condition surveys of Mississauga Road and Bush Street were undertaken in May 2010. The survey was conducted in accordance with the procedures outlined in MTO's Pavement Design and Rehabilitation Manual (SDO-90-01). The Pavement Condition Evaluation Forms are included in Appendix B.

The table presented herein are summaries of the pavement distress features noted for the evaluated pavement sections.

Section	From	To	Overall Condition	General Distresses
Mississauga Road	36+900	40+000	PCR = 60 RCR = 6.0  Good	<ul style="list-style-type: none"> <li>• Few slight ravelling &amp; coarse aggregate loss</li> <li>• Frequent slight wheel track rutting</li> <li>• Few slight distortion</li> <li>• Few severe single and multiple centre line cracking</li> <li>• Few moderate single and multiple pavement edge cracking</li> <li>• Intermittent slight alligator pavement edge cracking</li> <li>• Few moderate half, full and multiple transverse cracks</li> <li>• Intermittent moderate alligator transverse cracking</li> <li>• Intermittent moderate longitudinal meander and midlane cracking</li> <li>• Few moderate random/map cracking</li> </ul>
Mississauga Road	40+000	43+030	PCR = 65 RCR = 6.5  Good	<ul style="list-style-type: none"> <li>• Few slight surface deformations</li> <li>• Few moderate centre line cracking</li> <li>• Intermittent moderate pavement edge cracking</li> <li>• Few moderate transverse cracking</li> <li>• Few moderate longitudinal meander and midlane cracking</li> <li>• Few moderate random/map cracking</li> </ul>



Section	From	To	Overall Condition	General Distresses
Bush Street	-0+044	2+070	PCR = 75 RCR = 7.5  Good	<ul style="list-style-type: none"> <li>• Few slight wheel track rutting</li> <li>• Few moderate centre line cracking</li> <li>• Few slight pavement edge cracking</li> <li>• Few moderate transverse cracking</li> <li>• Few slight random/map cracking.</li> </ul>

#### 4 PHYSIOGRAPHY

The site is located in the physiographic region of Southern Ontario referred to as the Guelph Drumlin Field<sup>1</sup>. Within this area the dominant soil materials are the stony tills of the drumlins and deep gravel terraces of the old melt-water spillways.

The overburden materials in the project area are generally glaciofluvial outwash gravel and gravelly sand, frequently overlain by several metres of sand or silt.

#### 5 FIELD INVESTIGATIONS AND LABORATORY TESTING

##### 5.1 Field Work

The field investigations for this project were carried out from June 04 to June 11, 2010 after clearing all underground utilities and obtaining road cut permits. The work was performed in accordance with lane closure times specified by Peel Region.

The borehole locations were established by referring to physical landmarks such as driveways, intersections, house addresses and station numbers as appropriate. The approximate locations are shown in Figures 3 to 17.

A truck mounted drill rig was used to drill the boreholes by a specialist drilling contractor who was observed on a full time basis by a member of Terraprobe's technical staff. Pavement cores were also extracted with a 100 mm diameter coring bit.

The supervisor logged the boreholes and processed the recovered soil and core samples for transport to Terraprobe's laboratory for further examination and testing. The Log of Boreholes are presented in Appendix A of this report.

Falling Weight Deflectometer (FWD) pavement load/deflection testing was also carried out within the project limits. The FWD tests were completed in both lanes at 100 m intervals with test locations offset so that a measurement is collected every 50 m along the roadway. Additional tests were also completed in areas of localized pavement distress.

<sup>1</sup> Chapman and Putnam, "The Physiography of South Ontario", 3<sup>rd</sup> Edition, 1984.





Details of the field investigation are presented below.

- Coring and borehole drilling and sampling through the lanes of Mississauga Road in both directions. The granular thickness of the existing shoulders was also investigated at selected locations. Samples of the underlying granulars and subgrade soils were collected during the field investigations. These samples were subjected to a detailed visual inspection and selected samples were subjected to laboratory testing. Retrieved cores were transferred to Terraprobe's Laboratory for further visual examination, measurement and photography.
- Coring and borehole drilling and sampling through the lanes of Bush Street in both directions. The granular thickness of the existing shoulders was also investigated at selected locations. Samples of the underlying granulars and subgrade soils were collected during the field investigations. These samples were subjected to a detailed visual inspection and selected samples were subjected to laboratory testing. Retrieved cores were transferred to Terraprobe's Laboratory for further visual examination, measurement and photography.
- FWD testing along the north bound and south bound lanes of Mississauga Road and the east bound and west bound lanes of Bush Street.
- Visual pavement condition survey of Mississauga Road and Bush Street.

The borehole and core counts are summarised below.

ROAD COMPONENT	No. OF BOREHOLES	
	Main Lanes	Shoulders
Mississauga Road	37	16
Bush Street	13	6
<b>Total</b>	<b>50</b>	<b>22</b>

ROAD COMPONENT	No. OF CORES
Mississauga Road	3
Bush Street	2
<b>Total</b>	<b>5</b>



## 5.2 Laboratory Testing

The asphalt cores were examined visually, measured and photographed. Laboratory testing and visual examinations were carried out on the retrieved granular and soil samples.

The following laboratory tests and/or examinations were done:

- Moisture content (LS-701) of selected in situ subsoil and aggregate materials encountered during the field investigations.
- Particle Size Analysis (LS-702 & 602) of the different soils and aggregate materials.
- Visual examination of asphalt cores to determine the types and thickness of the various asphalt layers.

All tests were in accordance with the materials testing requirements and procedures outlined in the Laboratory Testing Manual of the Ministry of Transportation, or ASTM/AASHTO, as applicable. The laboratory testing was conducted at Terraprobe's Brampton laboratory. Laboratory test results are included in the borehole logs in Appendix A and the gradation curves, are presented in Appendix D.

## 6 SOIL AND PAVEMENT DATA

The soil and pavement conditions encountered within the project limits are briefly described below. Refer to Appendix A for borehole data, Appendix C for core data and photographs and Appendix D for laboratory test results.

### 6.1 Subgrade Soils

The subgrade soils below the existing pavement structure generally consist of clayey silt and silty clay fill, sandy silt and silty sand fill, native gravelly sand, sandy gravel, silty clay, silty sand and sandy silt.

#### 6.1.1 Mississauga Road

The pavement structure of Mississauga Road is summarized in the following table. Pavement core data and photographs are appended in Appendix C.

Location	Main Lanes Average Thickness (mm)			Shoulders Average Thickness (mm)
	HMA	Granular	Total	Granular
Sta. 36+900 – 37+325	160	525	685	690
Sta. 37+325 – 37+850	240	375	615	525
Sta. 37+850 – 38+850	200	335	535	390
Sta. 38+850 – 39+900	230	380	610	560
Sta. 39+900 – 40+500	275	265	540	470
Sta. 40+500 – 43+030	145	335	480	425



The granular base/subbase material of the pavement is in a compact to very dense state based on SPT "N" values that ranged from 11 blows to more than 50 blows for 0.3 m penetration. The moisture content of this granular material ranged from 3% to 11% by weight.

Gradation analyses were conducted on three samples of the granular base/subbase material and the results are referenced to OPSS Granular A and Granular B Type I specifications. These results are illustrated in Figure D1 in Appendix D.

Cohesionless fill material consisting of silty sand and sandy silt was encountered across the site. This fill extends to depth ranging from 0.6 m to 2.0 m below ground surface. The grain size distribution curves of samples of the silty sand to sandy silt fill are provided in Figure D2, Appendix D.

The blow counts from Standard Penetration Tests in this fill ranged from 7 blows to more than 50 blows for 0.3 m penetration indicating a loose to very dense relative density. The moisture content of samples of the fill ranged from 8% to 34% by weight.

Clayey silt to silty clay fill soils were encountered at some borehole locations extending to depths ranging from 0.8 m to 1.2 m below ground surface. Standard Penetration tests in this fill material gave "N" values that ranged from 14 blows to more than 50 blows for 0.3 m penetration. Based on these values the fill is considered to have a stiff to hard consistency. The moisture content of samples of this fill ranged from 21% to 24% by weight.

Native gravelly sand and sandy gravel deposits were encountered near the north limit of Mississauga Road approximately between Sta. 41+570 and Sta. 43+030. These deposits extend to depths ranging from 0.8 m to 2.0 m below ground surface. The grain size distribution curve of a sample of the gravelly sand is shown in Figure D3, Appendix D.

Based on SPT "N" values of 16 blows to more than 50 blows for 0.3 m penetration the gravelly sand and sandy gravel deposits are considered to have a compact to very dense relative density. The moisture content of samples from these deposits ranged from 4% to 14% by weight.

A silty clay deposit was encountered in Borehole 13 extending to a depth of 2.0 m below ground surface. A sample of this silty clay was subjected to a grain size analysis and the results are presented in Figure D4, Appendix D.

Standard Penetration tests in the silty clay gave "N" values that ranged from 13 to 19 blows for 0.3 m penetration. Based on these results the silty clay is considered to have a stiff to very stiff consistency. The moisture content of samples of this soil ranged from 14% to 18% by weight.

Silty sand and sandy silt deposits were encountered across the site extending to depths ranging from 1.4 m to 2.0 m below ground surface. The results of grain size distribution tests conducted on samples obtained from these deposits are illustrated in Figures D5 and D6.



Standard Penetration tests in these deposits yielded “N” values ranging from 4 blows to more than 50 blows per 0.3 m penetration indicating a loose to very dense relative density. The moisture content of retrieved soil samples ranged from 3% to 23% by weight.

Particle size analysis conducted on representative subgrade soil samples, indicate the following frost susceptibility:

- LSFH – Silty Sand and Sandy Silt Fill, Gravelly Sand, Silty Sand and Sandy Silt
- MSFH – Sandy Silt Fill and Silty Clay
- HSFH – Sandy Silt

### 6.1.2 Bush Street

The pavement structure of Bush Street is summarized in the following table. Pavement core data and photographs are appended in Appendix C.

Location	Main Lanes Average Thickness (mm)			Shoulders Average Thickness (mm)
	HMA	Granular	Total	Granular
Sta. -0+044 – 0+450	155	365	520	700
Sta. 0+450 – 0+950	305	255	560	540
Sta. 0+950 – 2+070	170	325	495	535

Standard Penetration Tests conducted in the granular base/subbase of the pavement yielded “N” values ranging from 12 blows to more than 50 blows for 0.3 m penetration. Based on these results the granular fill has a compact to very dense relative density. The moisture content of samples of the granular fill ranged from 4% to 18% by weight.

Gradation analyses were conducted on two samples of the granular base/subbase material and the results are referenced to OPSS Granular A and Granular B Type I specifications. These results are illustrated in Figure D7 in Appendix D.

Sandy silt fill was encountered at this site extending to depths ranging from 0.8 m to 1.7 m below ground surface. Grain size distribution curves of samples of this fill material are presented in Figure D8, Appendix D.

The blow counts from Standard Penetration Tests in this fill ranged from 6 blows to more than 50 blows for 0.3 m penetration indicating a loose to very dense relative density. The moisture content of samples of this fill ranged from 12% to 20% by weight.

A layer of silty clay fill was encountered in Borehole 40 extending to a depth of 2.0 m below ground surface. The grain size distribution curve of a sample of the silty clay fill is shown in Figure D9, Appendix D.

Standard Penetration tests in the silty clay fill gave “N” values that ranged from 12 blows to more than 50 blows for 0.3 m penetration. Based on these results the fill is considered to have a stiff to hard consistency. The moisture content of samples of this fill ranged from 10% to 34% by weight.



Native gravelly sand and sandy gravel subgrade soils were encountered within the depths of investigation. These soils extend to depths ranging from 1.5 m to 2.0 m below ground surface. The grain size distribution plot of a tested sample of the sandy gravel is presented in Figure D10, Appendix D.

Based on SPT "N" values that ranged from 13 blows to more than 50 blows for 0.3 m penetration the gravelly sand and sandy gravel are considered to have a compact to very dense relative density. The moisture content of retrieved soil samples ranged from 4% to 10% by weight.

Silty sand soils were encountered within the project limits extending to depths ranging from 1.7 m to 2.0 m below ground surface. Refer to Figure D11, Appendix D where the grain size distribution curve of a sample of the silty sand is depicted.

The silty sand deposits are considered to have a compact to very dense relative densities based on SPT "N" values that ranged from 26 blows to more than 50 blows for 0.3 m penetration. The moisture content of these soils ranged from 4% to 17% by weight.

Particle size analysis conducted on representative subgrade soil samples, indicate the following frost susceptibility:

- LSFH – Sandy Silt Fill, Sandy Gravel and Silty Sand
- MSFH – Sandy Silt Fill and Silty Clay Fill

## **6.2 Groundwater Conditions**

Water level observations were made in each borehole during and after completion of drilling. Free water was encountered in Boreholes 6, 7A and 15 at depths ranging from 0.6 m to 0.9 m below ground surface. The remaining boreholes were dry and open to full depth.

## **6.3 Bedrock**

Bedrock was not encountered within the depths of investigation.

## **7 BORROW MATERIALS**

Only approved earth fill must be used on this project. Granular material obtained from removals below existing shoulders can be utilised as fill material for this project provided it is free of topsoil and other deleterious material.

The frost susceptibility of the native soils at this site ranges widely from low frost susceptibility to high frost susceptibility and it is imperative that careful control and monitoring be implemented to ensure that only acceptable approved fill is used.



Soils of low to medium frost susceptibility can be used as fill up to the proposed design subgrade elevation. Soils with high frost susceptibility are not recommended for re-use within a zone extending to a minimum depth of 1 m below the proposed pavement subgrade. These soils should be segregated and used elsewhere.

## **8 AGGREGATE/GRANULAR MATERIALS**

The aggregates and granular materials should satisfy the requirements given in Special Provision 110F13.

It is recognized that there is a potential for reusing the existing granular material at this site and the materials suitability for re-use should therefore be further assessed. This can be accomplished by collecting and testing additional representative samples of the granular material from below the roadway and its gravel shoulder during detail design.

## **9 ALIGNMENT AND GRADELINE**

No major areas of geotechnical concern were encountered in the boreholes extended within the project limits.

## **10 PAVEMENT DESIGNS**

The pavement structures were designed based on traffic information and design criteria provided by the Region of Peel and the data obtained from the field investigations and FWD testing. Preliminary pavement designs were undertaken for new construction and rehabilitation of the existing roadways.

The following references and guidelines were used for the pavement designs.

- MTO's "Adaptation and Verification of AASHTO Pavement Design Guide for Ontario Conditions", MI-183, March 2001.
- AASHTO Guide for the Design of Pavement Structures, 1993.
- "Procedures for Estimating Traffic Loads for Pavement Designs", Hajek J., 1995.



### 10.1 Design Parameters

The pavement was designed using AASHTOWare DARWin 3.1, a proprietary pavement design software. The AASHTO pavement design parameters used for the pavement design are presented in the following table.

DESIGN PARAMETER	MISSISSAUGA ROAD & BUSH ST.
Initial/Terminal Serviceability Index	$P_i = 4.2$ $P_t = 2.2$
Loss in Serviceability index	2.0
Desired Reliability (%) and Standard Deviation	$R = 85$ $SD = 0.44$
Estimated Elastic Modulus of Subgrade Soil (MPa)	20 – 30
Estimated Cumulative ESALS (20 yr Design Period)	1,154,250 (Mississauga Rd.) 334,565 (Bush St.)
Layer Coefficients of Hot Mix Asphalt (HMA)	New HMA = 0.42 Existing HMA=0.28
Layer Coefficient RAP/Granular Blend	0.10
Layer Coefficient of Granular Materials	Granular A=0.14 Granular B = 0.09 Pulverized HMA/Granular Mix = 0.1 Existing Granular = 0.07
Drainage Coefficient	$m = 1$ (new granular base & subbase) $m = 0.9$ (existing granular material)

### 10.2 Mississauga Road

The granular thickness of the pavement base and subbase is highly variable along this section of the alignment and reliable performance can only be guaranteed if a sufficiently thick and uniform base and subbase is provided.

The field investigations indicate “bathtub” construction i.e. the shoulder granulars are generally thinner than the granular base/subbase below the roadway. Inadequate and substandard ditches also exist within the project limits. Hence, reliable lateral drainage cannot be guaranteed.

It is also noted that the grade profile will be adjusted (raising and lowering) over relatively short distances in order to improve sight lines.

Given these constraints we recommend that the roadway be rehabilitated by full depth reconstruction. For the design traffic loads the flexible pavement structure required for new construction is:

HL-1 or Superpave 12.5 FC1 Surface Course	50 mm
HL-8 or Superpave 19 Binder Course	100 mm
Granular A Base	150 mm
Granular B Type I Subbase	400 mm
Total Depth	700 mm
Structural Number	120 mm
Granular Base Equivalency	717 mm



For partially paved shoulders the top two lifts of asphalt should be extended over the shoulder.

### **10.3 Bush Street**

The structural capacity of the existing pavement structure of Bush Street was evaluated using AASHTO's pavement overlay design procedure. Designs were undertaken over a service life extension of 20 years. The structural number of the existing pavement is about 75 mm and the required minimum structural number is 97 mm. Based on the foregoing the existing pavement requires strengthening in order to carry the design traffic loads over a 20 year service life extension.

The granular thickness of the pavement base and subbase is variable along this section of the alignment and reliable performance can only be guaranteed if a sufficiently thick and uniform base and subbase is provided. It is also noted that the grade profile of Bush Street will be adjusted (raising and lowering) over relatively short distances in order to improve sight lines.

Due to the foregoing, the presence of frequent cracks in the pavement and considering its age, a rehabilitation strategy involving a straight overlay will not be suitable. Moreover, a high level of reliability is warranted.

A rehabilitation strategy that involves full depth reclamation of the bituminous pavement and a portion of the underlying granular can be considered. However, the existing asphalt is thicker than 125 mm and partial depth milling will be required to reduce the asphalt thickness to 125 mm to allow for optimum pulverization of the asphalt and underlying granular material.

The following rehabilitation strategy can be considered:

- Pulverise 125 mm of the existing asphalt and 125 mm of the underlying granular material in-place for a total depth of 250mm.
- Compact pulverized RAP/granular blend.
- Pave roadway with 140 mm of HMA consisting of 40 mm of HL1 or Superpave FC1 surface course and 100 mm of HL8 or Superpave 19 binder course.

Since this rehabilitation strategy will result in a grade raise, the proposed design profile will have to be adjusted to accommodate this grade raise.





If a grade raise cannot be accommodated, then full depth reconstruction should be considered. For the design traffic loads the flexible pavement structure required for new construction is:

HL-1 or Superpave 12.5 FC1 Surface Course	40 mm
HL-8 or Superpave 19 Binder Course	100 mm
Granular A Base	150 mm
Granular B Type I Subbase	400 mm
Total Depth	690 mm
Structural Number	116 mm
Granular Base Equivalency	695 mm

For partially paved shoulders the top two lifts of asphalt should be extended over the shoulder. In order to ensure reliable lateral drainage the granular thickness in the widening areas may have to be increased at some locations to match existing granular. Further investigations of the existing shoulders will be required at the detail design to explore this issue further.

## 11 RECOMMENDATIONS AND CONSTRUCTION FEATURES

### 11.1 Pavement Structure (Material Types)

The following mix types are considered suitable for this project.

- HL1 or Superpave 12.5 FC1 Surface Course
- HL8 or Superpave 19 Binder Course

Granular A should be used for the shoulders and as base material for all new roadways. Granular B Type I is recommended as subbase material.

### 11.2 Padding

HL 3HS hot mix asphalt (or alternatively Superpave 9.5 for Superpave mixtures) is recommended as padding. Padding should be placed in lifts not exceeding 50 mm.

### 11.3 Asphalt Cement Grade

The recommended performance grade asphalt cement for surface course as well as binder course layers is PG 64-28. PG 58-28 should be used for all other mixes.

### 11.4 Tack Coat

SS1 Tack Coat must be applied to all existing or milled surfaces and between all new lifts of hot mix asphalt.



## **11.5 Pavement Tapers**

At the limits of construction, appropriate tapering of pavement thickness to match the existing pavement structure should be implemented in accordance with OPSS or applicable Region of Peel practice.

## **12 CUT MATERIALS AND DESIGN**

No slope stability problems are anticipated in shallow cut sections less than 4 m deep provided that these slopes are not constructed steeper than 2H:1V.

Adequate ditching must be provided and the slopes should be vegetated as soon as possible by seeding/mulching to control erosion.

## **13 EMBANKMENT MATERIALS AND DESIGN**

The placement of borrow material must be carefully monitored and properly compacted to ensure adequate support for the pavement. Mixing of materials from different sources is not recommended due to the risks associated with differential settlement, drainage problems and frost heave.

No slope stability problems are anticipated for earth fills constructed at minimum 2H:1V side slopes. However, seeding/mulching should be undertaken as soon as possible to control erosion.

Where existing embankments are to be widened the new fill material should be benched into the existing slope as per current OPSD standards.

The moisture content of the fill material at the time of construction shall be within 2% of the optimum moisture content. Reconditioning of the material to achieve optimum moisture content may be required prior to placement.

## **14 DRAINAGE**

### **14.1 Culvert Bedding, Cover and Backfill**

Bedding for CSP and/or minor concrete pipe culverts should be in accordance with the OPSD 802 series. Granular A material is recommending for bedding and cover to these minor culverts. Clean native material can also be used as cover for minor culverts provided it is placed below the design frost depth.

Granular frost tapers will be required when the frost line is below the top of culvert. Culvert installations should be undertaken in accordance with Region of Peel Standard Drawing 5-2-4.



## 14.2 Ditches

Ditches are required to collect and remove excess surface water and the grading should be in accordance with OPSD 200.010. In cut sections the ditch will be located adjacent to the roadway and the ditch invert must be at least 0.5 m below the top of the subgrade. For fill sections the ditch invert should extend at least 0.25 m below the base of the fill and should be separated at least 1.5 m horizontally from the toe of the fill.

To promote drainage of the pavement structure, the base granulars must extend across the full width of the roadway and must daylight in the ditches.

In all areas where a curb and gutter is proposed (urban sections), full-length subdrains placed beneath the curb in accordance with OPSD 216.020 is recommended for pavement drainage. In localized wet areas a subdrain system may be required.

Subdrains should consist of filter wrapped perforated plastic pipe subdrain placed in a trench excavated 300 mm by 300 mm into the subgrade. The trench should be backfilled with 19 mm clear stone. The subdrain pipe should be connected to a positive outlet. A typical subdrain detail is illustrated in Appendix E.

## 15 OTHER DESIGN FEATURES

### 15.1 Compaction

All granular base and subbase materials should be placed in 150 mm lifts and compacted to 100% of Standard Proctor Maximum Dry Density (SPMDD) at  $\pm 2\%$  of Optimum Moisture Content (OMC). Asphalt concrete should be placed in maximum 50 mm lifts and compacted in accordance with the appropriate OPSS or Region of Peel specifications.

### 15.2 Excavations

Excavations will be made through fill material (pavement granular, silty sand, sandy silt, clayey silt and silty clay), and native deposits comprising of silty clay, gravelly sand, sandy gravel, silty sand and sandy silt. Excavations must be carried out in accordance with the Occupational Health and Safety Act (OHSA). For the purposes of the OHSA, the soils at this site may be classified as:

- Fill material – Type 3 soils above the water table and Type 4 soils below the water table
- Silty clay – Type 2 soil above the water table and Type 3 soil below the water table
- Gravelly sand, sandy gravel, silty sand and sandy silt – Type 3 soils above the water table and Type 4 soils below the water table

Where workers must enter excavations extending deeper than 1.2 m, the trench walls must be suitably sloped and/or braced in accordance with the Occupational Health and Safety Act and Regulations for Construction Projects.



### 15.3 Frost Penetration

For design purposes assume a frost penetration depth of 1.2 m.

### 15.4 Soil Disposition

Eight soil samples were submitted to AGAT Laboratories for chemical characterization with respect to general inorganic parameters including metals, pH, sodium adsorption ratio (SAR) and electrical conductivity (EC). These are nominal parameters analysed when there are no indications of environmental impacts.

The analytical results were compared to Table 1 (Agricultural or Other Types of Property Use) of the MOE Soil, Ground Water and Sediment Standards for Use Under Part XV.1 of the Environmental Protection Act. It is anticipated that these results will be used to determine disposal options for excess soils generated during construction.

Comparison of the test results indicates that the metal concentrations were generally below the remediation concentrations stipulated in Table 1 with the exception of the tested soil sample in Borehole 49 where the copper concentration exceeds the "Agricultural or Other Property Use" guideline limit. The copper concentration however meets "All Other Types of Property Uses" in Table 1.

The SAR and chloride concentrations and electrical conductivity values also exceed the guideline limits in the tested soil samples which likely reflect the impact of road salting operations. The SAR and chloride concentrations and electrical conductivity values are compared with the remediation concentrations of MOE Table 1.

Parameter	Sample Number and Location				MOE Guideline Standards
	BH 2 0.8 – 1.4 m	BH 9 0.3 – 0.6 m	BH 15 0.6 – 0.8 m	BH 26 0.3 – 0.6 m	
Electrical Conductivity	4.86	1.23	1.56	1.22	0.47
SAR	75.7	21.5	19.7	15.9	1.0
Chloride	3710	703	917	726	58

Parameter	Sample Number and Location				MOE Guideline Standards
	BH 38 0.8 – 1.4 m	BH 40 0.3 – 0.6 m	BH 46 0.3 – 0.6 m	BH 49 0.8 – 1.4 m	
Electrical Conductivity	6.97	7.35	5.37	3.05	0.47
SAR	51.5	103	66.2	58.4	1.0
Chloride	5460	5680	4150	2110	58

Debris or stained/odorous soils, which are encountered during excavation, should be segregated and re-evaluated for disposal or re-use as fill and may require additional analysis.



## **16 LIMITATIONS AND RISK**

### **16.1 Procedures**

This investigation has been carried out using investigation techniques and engineering analysis methods consistent with those ordinarily exercised by Terraprobe and other engineering practitioners, working under similar conditions and subject to the time, financial and physical constraints applicable to this project. The discussions and recommendations that have been presented are based on the factual data obtained.

It must be recognized that there are special risks whenever engineering or related disciplines are applied to identify subsurface conditions. Even a comprehensive sampling and testing programme implemented in accordance with the most stringent level of care may fail to detect certain conditions. Terraprobe has assumed for the purposes of providing preliminary design parameters and advice, that the conditions that exist between sampling points are similar to those found at the sample locations. The conditions that Terraprobe has interpreted to exist between sampling points can differ from those that actually exist.

It may not be possible to drill a sufficient number of boreholes or sample and report them in a way that would provide all the subsurface information that could affect construction costs, techniques, equipment and scheduling. Further investigations will be required in order to undertake a detail design.

### **16.2 Changes in Site and Scope**

It must also be recognized that the passage of time, natural occurrences, and direct or indirect human intervention at or near the site have the potential to alter subsurface conditions. Groundwater levels are particularly susceptible to seasonal fluctuations.

The discussion and recommendations are based on the factual data obtained from preliminary investigations made by Terraprobe and are intended for use by the owner and its retained designers in the preliminary design phase of the project and further investigations will be required for detail design. If there are changes to the project scope and development features the interpretations made of the subsurface information, the geotechnical design parameters and comments relating to constructability issues and quality control may not be relevant or complete for the revised project. Terraprobe should be retained to review the implications of such changes with respect to the contents of this report

This report was prepared for the express use of the Region of Peel, Dillon Consulting Limited and their retained design consultants and is not for use by others. This report is copyright of Terraprobe Inc. and no part of this report may be reproduced by any means, in any form, without the prior written permission of Terraprobe Inc. Dillon Consulting Limited, The Regional Municipality of Peel and their retained design consultants are authorized users.



**DRAFT**

Engineering Analysis and Report Preparation by:  
Hussein Ahmed, P.Eng.,  
Geotechnical Engineer

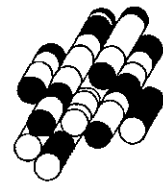
**DRAFT**

Report Reviewed by:  
R. Abdul, P.Eng.,  
Senior Geotechnical Engineer, Associate



# FIGURES

**Terraprobe Inc.**







# MISSISSAUGA ROAD



South project limit looking north.



Sta. 38 + 000 approximately looking south.

# MISSISSAUGA ROAD



Sta. 41 + 500 approximately looking north.



Sta. 42 + 825 approximately looking north.

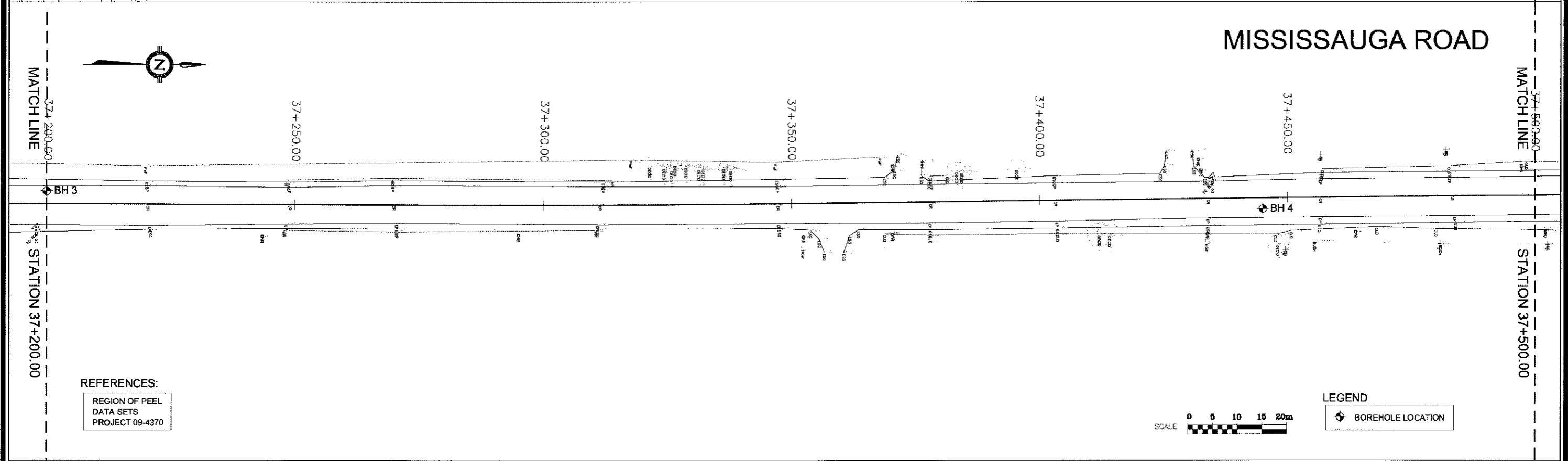
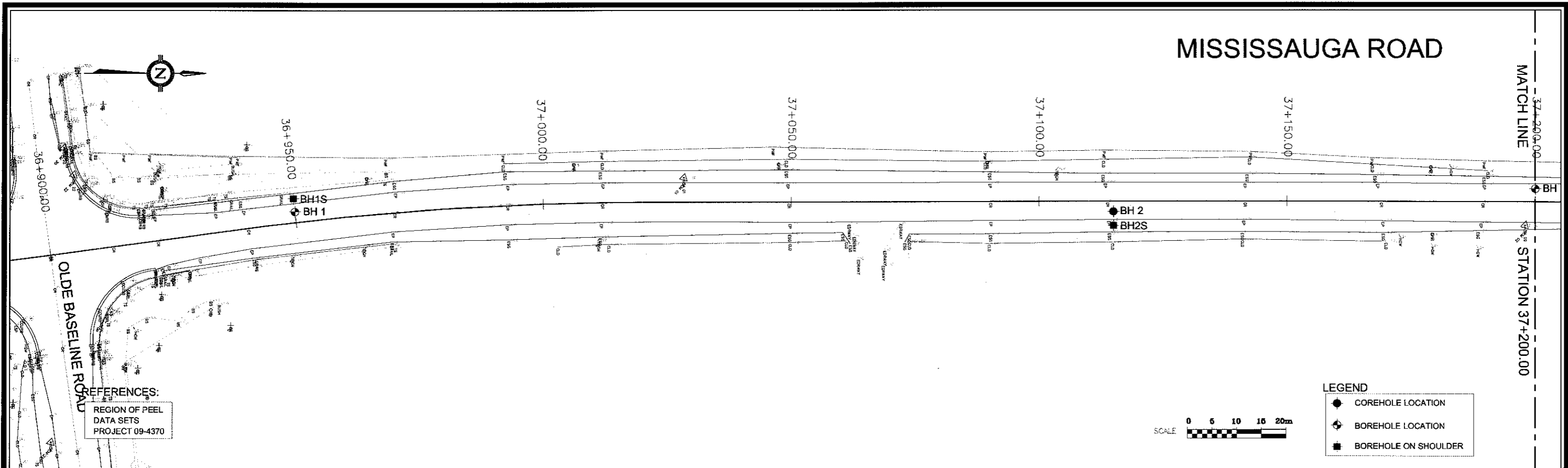
# BUSH STREET



Sta. 0 + 000 approximately looking east.



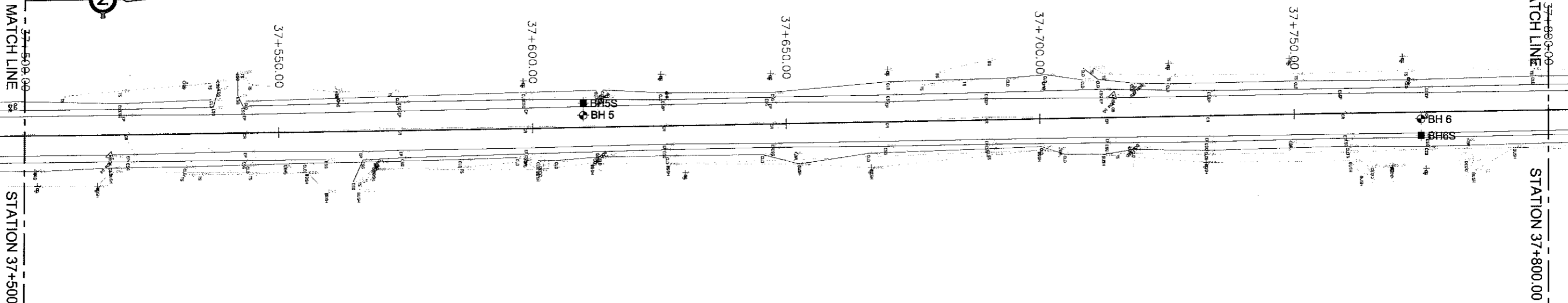
Sta. 2 + 050 approximately looking west.



**BOREHOLE LOCATION PLAN**

I:\Projects\2010 Files\1-10-5056\1-10-5056.dwg, Log\AutoCAD\1-10-5056 Road Adjustment Mississauga R2, version\printmg, KBL\N

# MISSISSAUGA ROAD

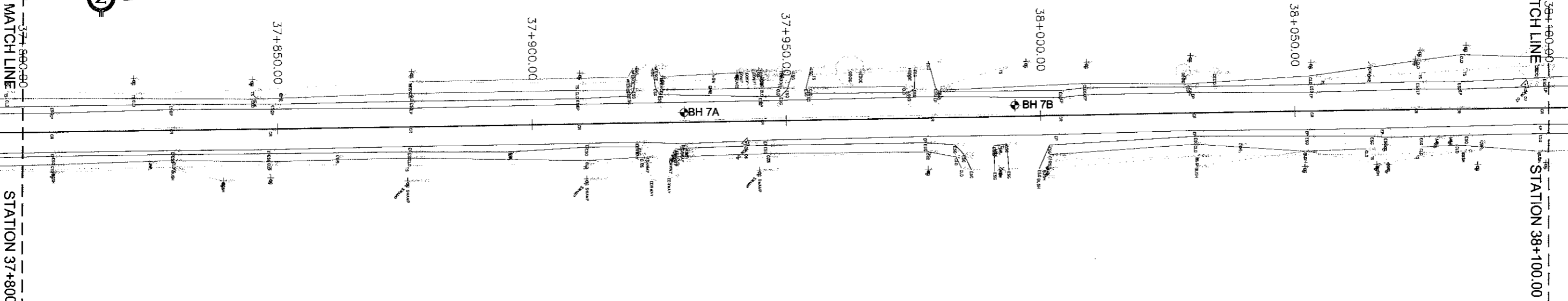


REFERENCES:  
 REGION OF PEEL  
 DATA SETS  
 PROJECT 09-4370

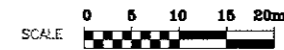


LEGEND  
 ◆ BOREHOLE LOCATION  
 ■ BOREHOLE ON SHOULDER

# MISSISSAUGA ROAD



REFERENCES:  
 REGION OF PEEL  
 DATA SETS  
 PROJECT 09-4370



LEGEND  
 ◆ BOREHOLE LOCATION

## BOREHOLE LOCATION PLAN

\\terraprobe\res\TerraProbe Limited\AMT\Projects\010\Files\1-10-5056\1-10-5056\_Road Adjustment Mississauga Rd\_west\010\TERRAPROBE.DWG

# MISSISSAUGA ROAD

MATCH LINE

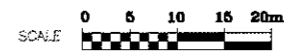
STATION 38+400.00

MATCH LINE

STATION 38+100.00

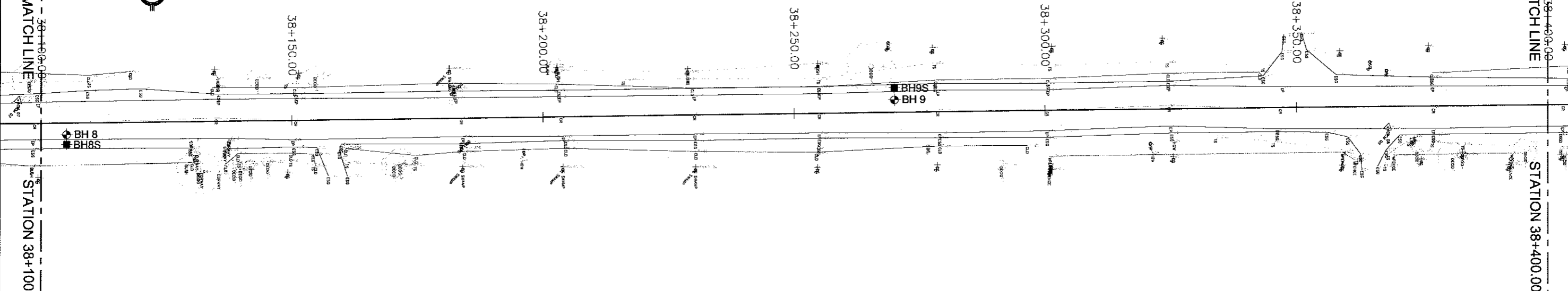


REFERENCES:  
REGION OF PEEL  
DATA SETS  
PROJECT 09-4370



### LEGEND

- ◆ BOREHOLE LOCATION
- BOREHOLE ON SHOULDER



# MISSISSAUGA ROAD

MATCH LINE

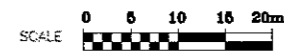
STATION 38+700.00

MATCH LINE

STATION 38+400.00

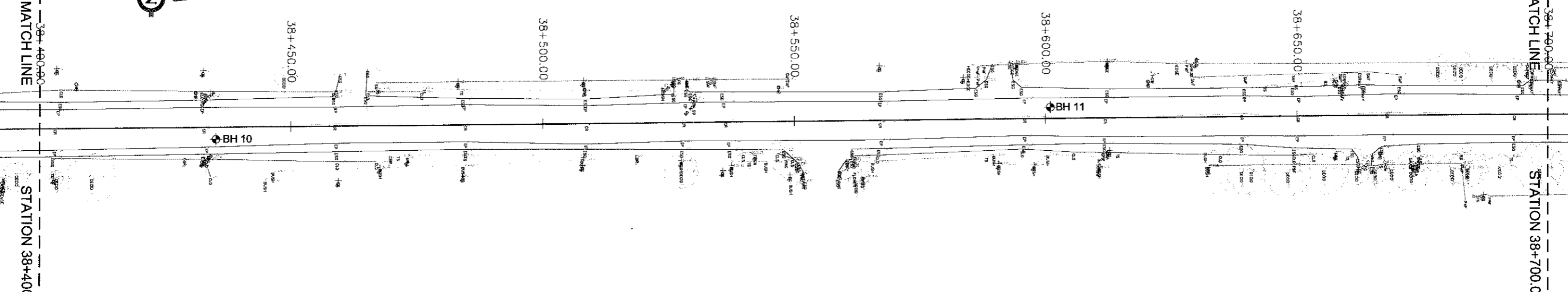


REFERENCES:  
REGION OF PEEL  
DATA SETS  
PROJECT 09-4370



### LEGEND

- ◆ BOREHOLE LOCATION



## BOREHOLE LOCATION PLAN

MISSISSAUGA ROAD

MATCH LINE

STATION 39+000.00

MATCH LINE

STATION 38+700.00



38+750.00

38+800.00

38+850.00

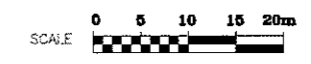
38+900.00

38+950.00

BH 12  
BH12S

BH 13  
BH13S

REFERENCES:  
REGION OF PEEL  
DATA SETS  
PROJECT 09-4370



LEGEND  
◆ BOREHOLE LOCATION  
■ BOREHOLE ON SHOULDER

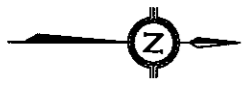
MISSISSAUGA ROAD

MATCH LINE

STATION 39+300.00

MATCH LINE

STATION 39+000.00



39+050.00

39+100.00

39+150.00

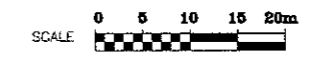
39+200.00

39+250.00

BH 14

BH 15

REFERENCES:  
REGION OF PEEL  
DATA SETS  
PROJECT 09-4370

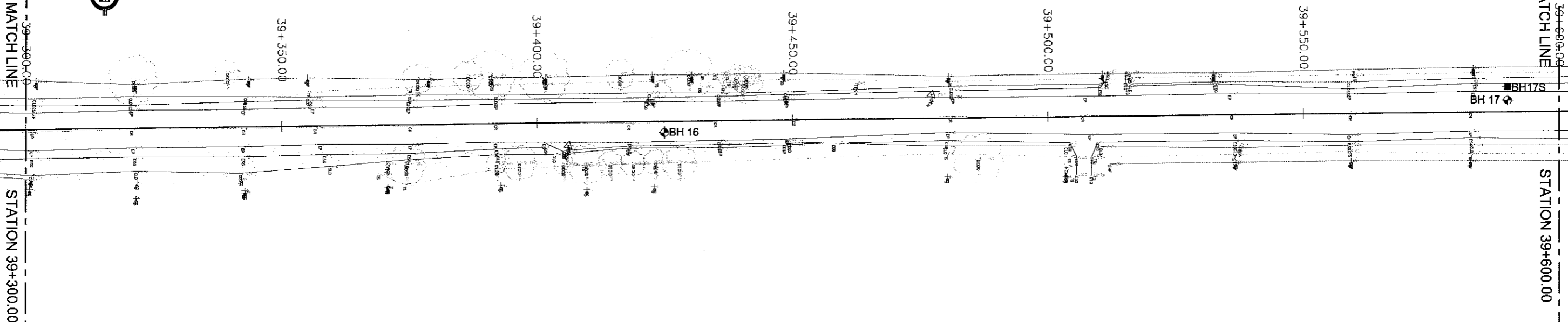


LEGEND  
◆ COREHOLE LOCATION  
◆ BOREHOLE LOCATION

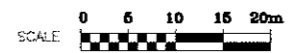
BOREHOLE LOCATION PLAN

\\TerraProbe\fileserver\TerraProbe\_Limited\All Projects\1-10-5056\1-10-5056\_09-4370\Drawings\09-4370-01-116595.dwg, 09-4370-01-116595.dwg, 10-5056-01-116595.dwg, 10-5056-01-116595.dwg

# MISSISSAUGA ROAD

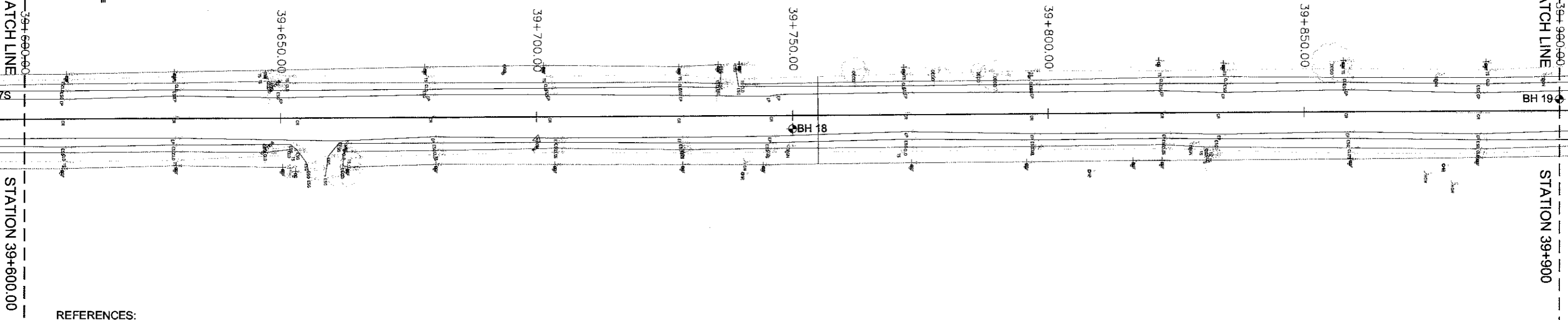


REFERENCES:  
 REGION OF PEEL  
 DATA SETS  
 PROJECT 09-4370

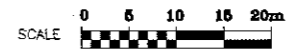


LEGEND  
 ◊ BOREHOLE LOCATION  
 ■ BOREHOLE ON SHOULDER

# MISSISSAUGA ROAD



REFERENCES:  
 REGION OF PEEL  
 DATA SETS  
 PROJECT 09-4370



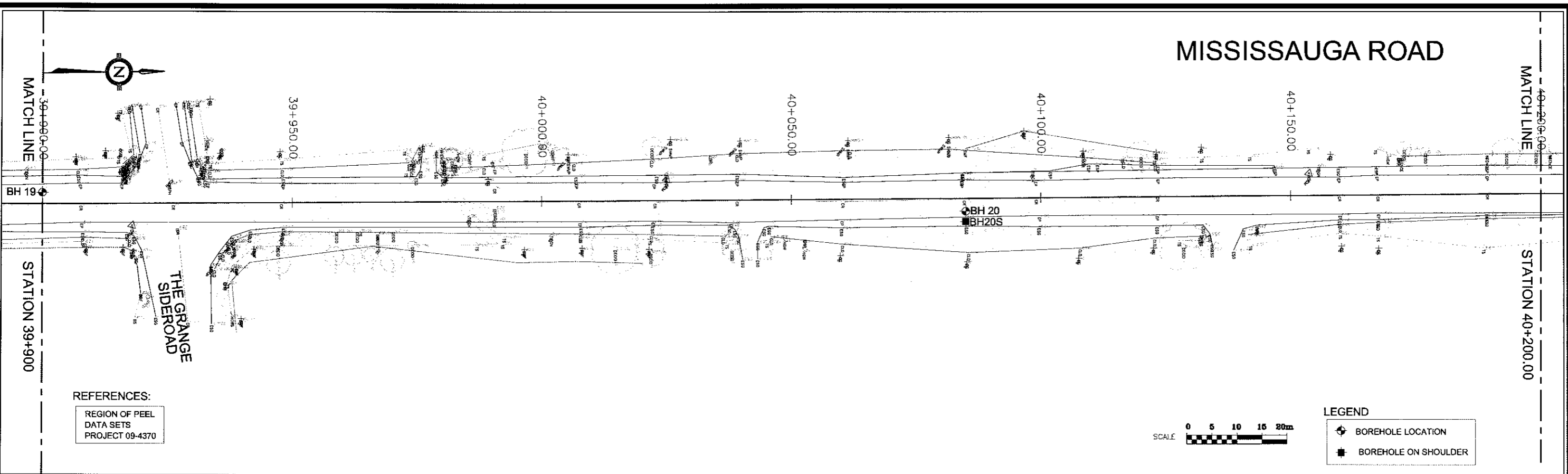
LEGEND  
 ◊ BOREHOLE LOCATION

## BOREHOLE LOCATION PLAN

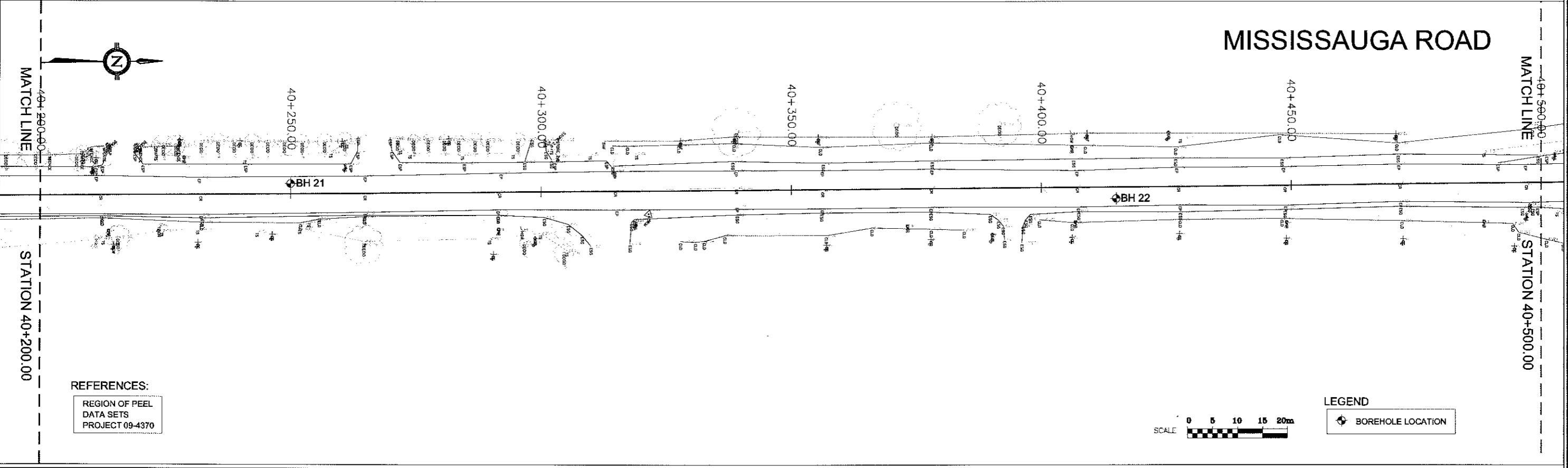
I:\Terraprobe\Inventories\Terraprobe Invenet\Terraprobe Invenet\1-10-5056 Road Adjustment\Mississauga Road\Road Adjustment\Mississauga Road\BOREHOLE LOCATION PLAN\BOREHOLE LOCATION PLAN.dwg, Date: 11/15/2006, by: 1000, File: 1-10-5056



# MISSISSAUGA ROAD

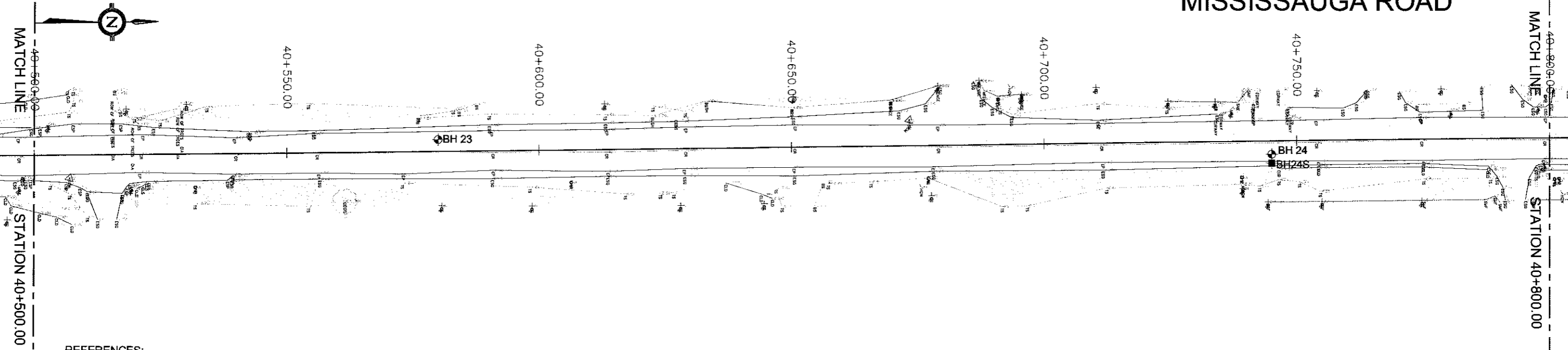


# MISSISSAUGA ROAD



## BOREHOLE LOCATION PLAN

# MISSISSAUGA ROAD



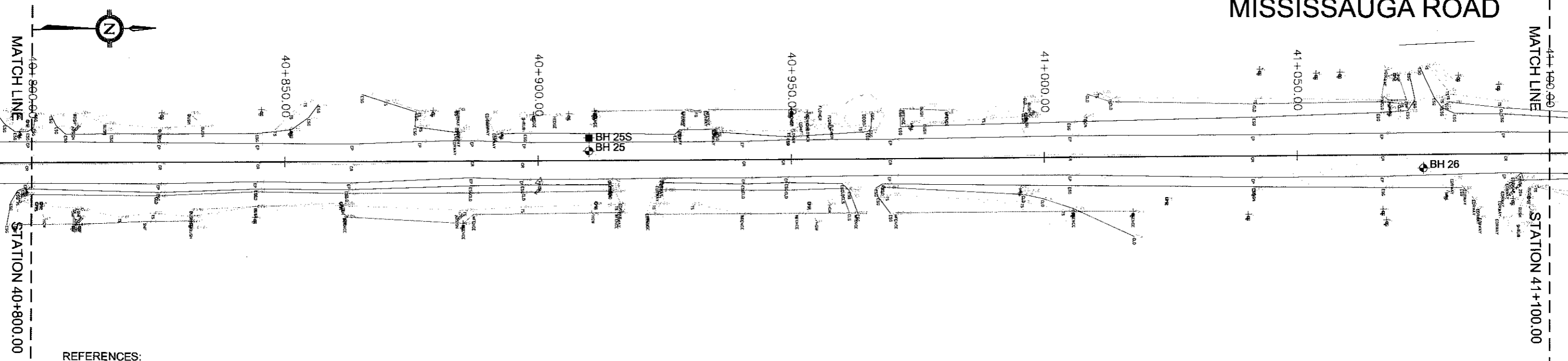
REFERENCES:  
REGION OF PEEL  
DATA SETS  
PROJECT 09-4370

LEGEND

- ◆ BOREHOLE LOCATION
- BOREHOLE ON SHOULDER

SCALE 0 5 10 15 20m

# MISSISSAUGA ROAD



REFERENCES:  
REGION OF PEEL  
DATA SETS  
PROJECT 09-4370

LEGEND

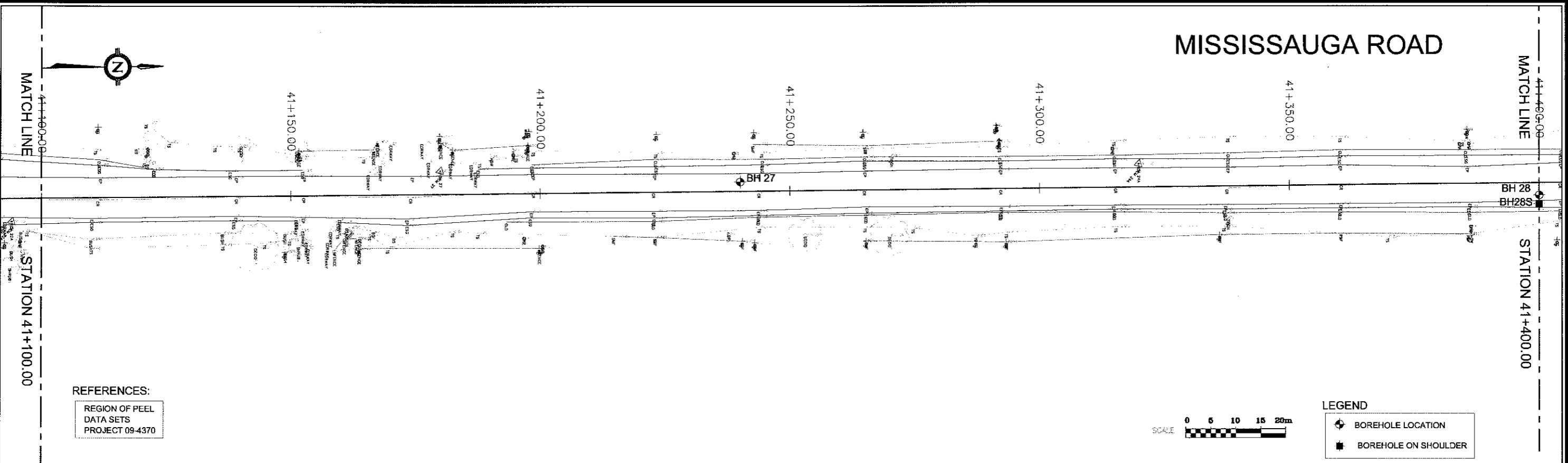
- ◆ BOREHOLE LOCATION
- BOREHOLE ON SHOULDER

SCALE 0 5 10 15 20m

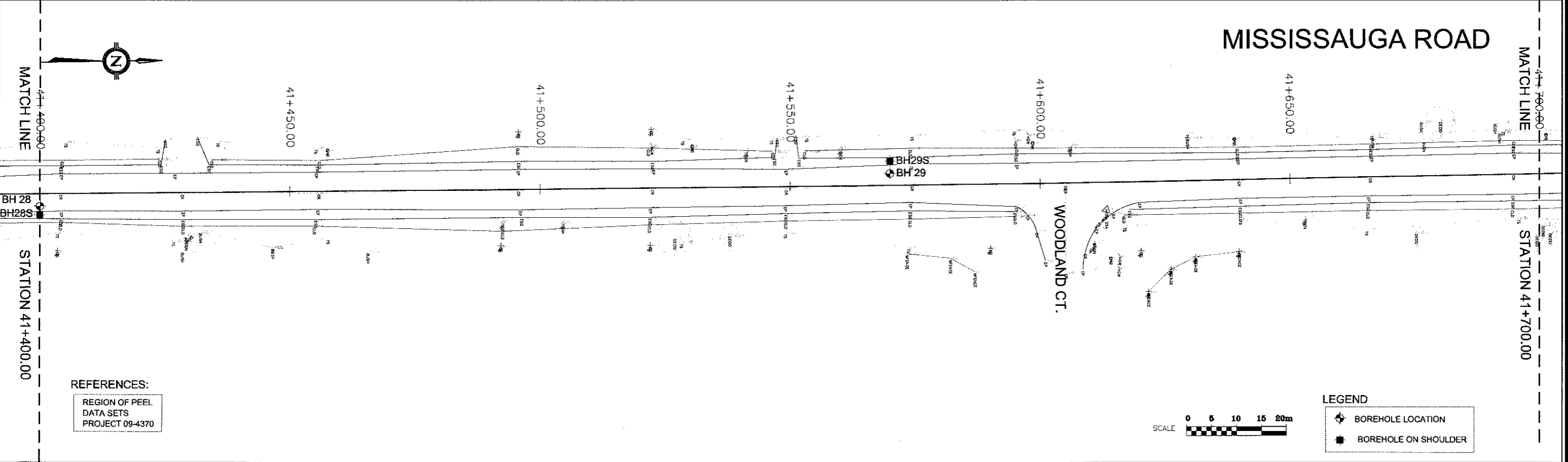
## BOREHOLE LOCATION PLAN

\\Terraprobe\Research\Terraprobe\_Limitada\Projects\09-4370\09-4370-1000\Map\Station 40+500.00 to 40+800.00.dwg

# MISSISSAUGA ROAD



# MISSISSAUGA ROAD



## BOREHOLE LOCATION PLAN

\\TerraProbe\server\Users\paul.van@terraprobe.com\Projects\1-10-5056\1-10-5056.dwg

MISSISSAUGA ROAD

MATCH LINE 42+000.00

MATCH LINE 41+700.00



41+750.00 41+800.00 41+850.00 41+900.00 41+950.00

BH 30

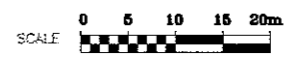
BH 31

CALEDON MOUNTAIN DRIVE

STATION 42+000.00

REFERENCES:  
REGION OF PEEL  
DATA SETS  
PROJECT 09-4370

LEGEND



BOREHOLE LOCATION

OLD MAIN STREET

MATCH LINE 42+200.00

OLD MAIN STREET

STATION 42+200.00

CALEDON MOUNTAIN DRIVE

MATCH LINE 42+000.00

STATION 42+000.00

42+050.00

BH 32

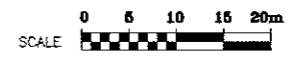
42+100.00

42+150.00

OLD MAIN STREET

REFERENCES:  
REGION OF PEEL  
DATA SETS  
PROJECT 09-4370

LEGEND

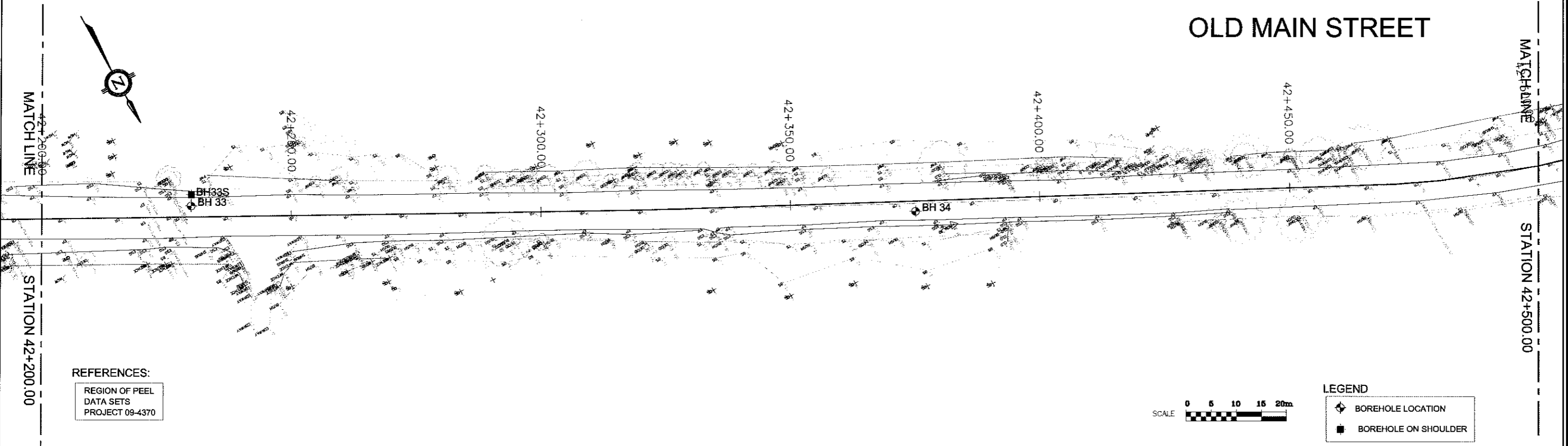


COREHOLE LOCATION  
BOREHOLE LOCATION  
BOREHOLE ON SHOULDER

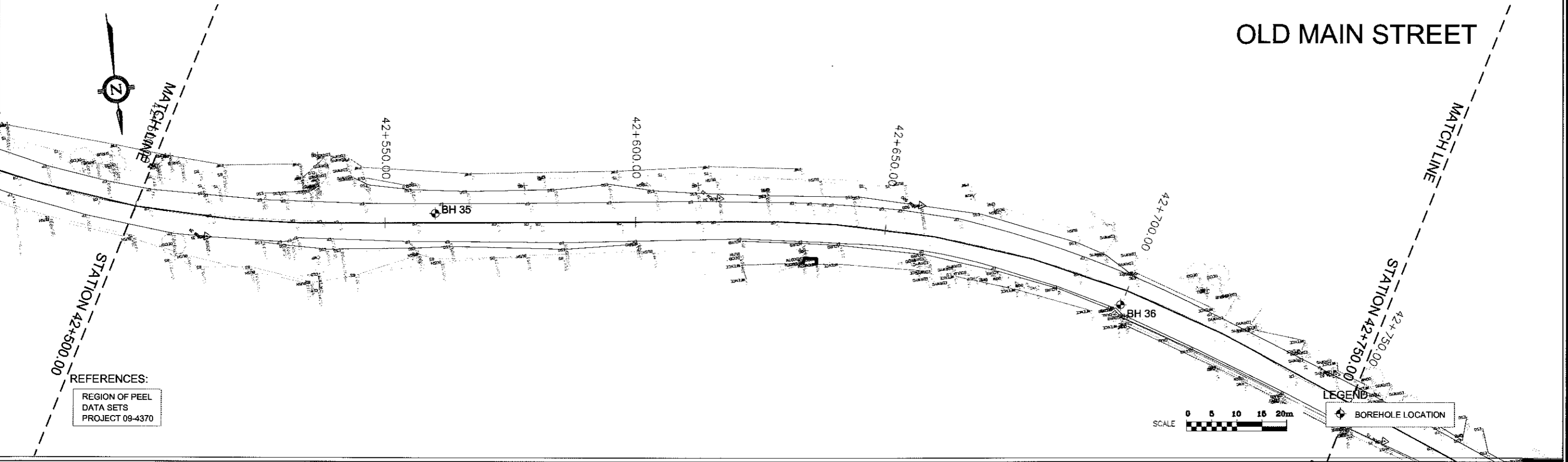
BOREHOLE LOCATION PLAN

I:\TerraProbe\reserv\TerraProbe\1-10-5056\1-10-5056-01-10-5056.dwg

**OLD MAIN STREET**

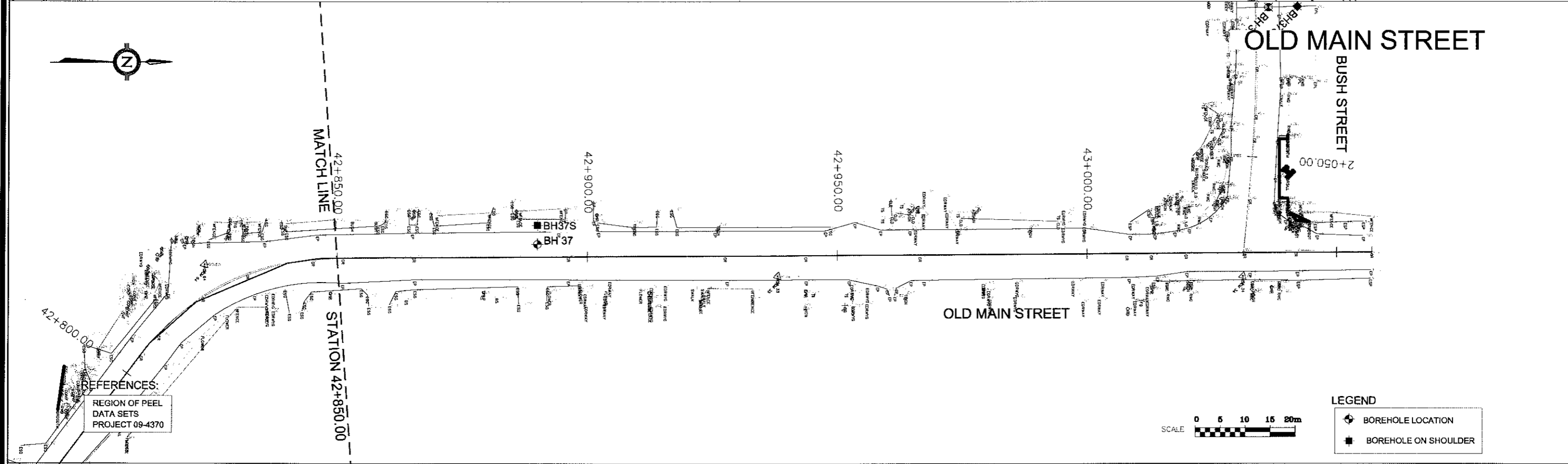
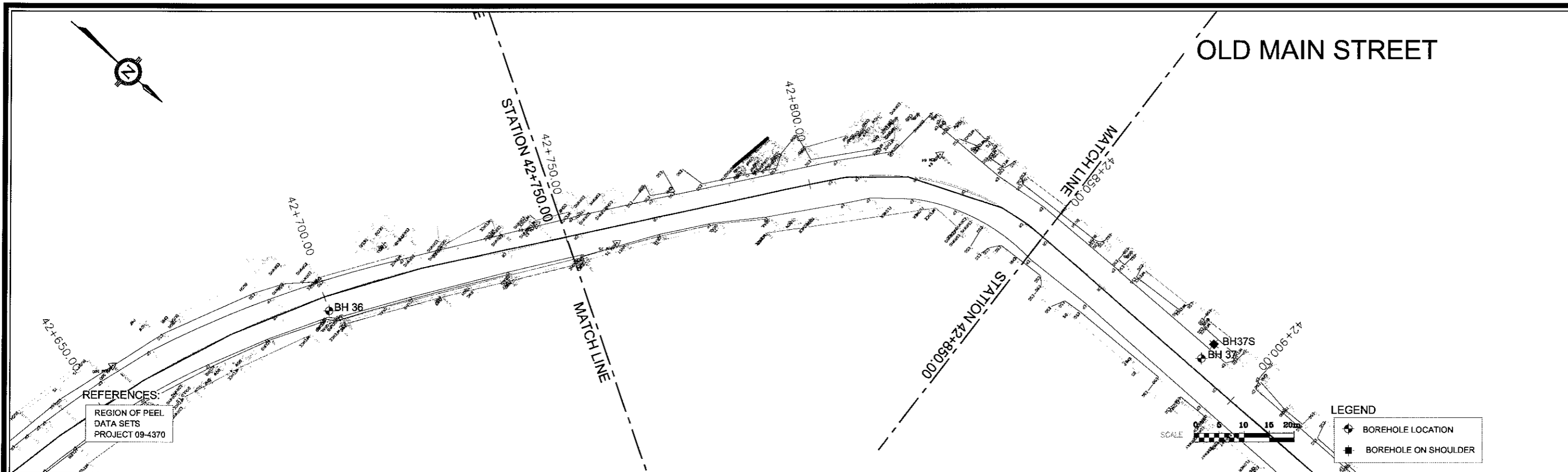


**OLD MAIN STREET**



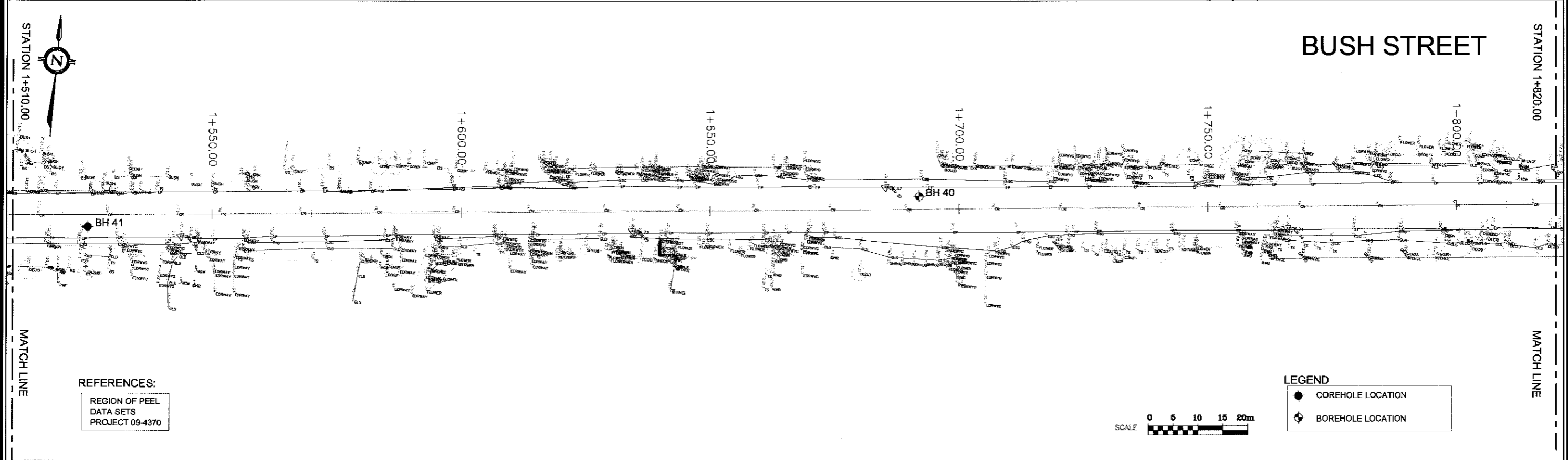
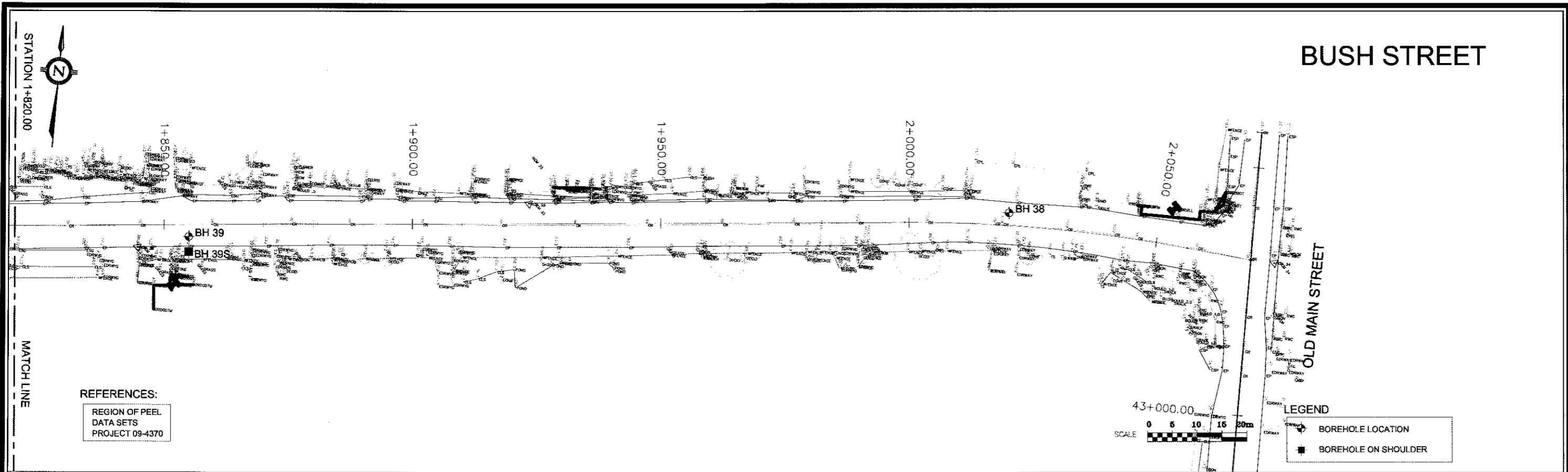
**BOREHOLE LOCATION PLAN**

\\TerraProbe\fileserver\1\user\p\p\Projects\09-4370\Drawings\09-4370-1-10-5056.dwg 10/26/2010 10:58:09 AM



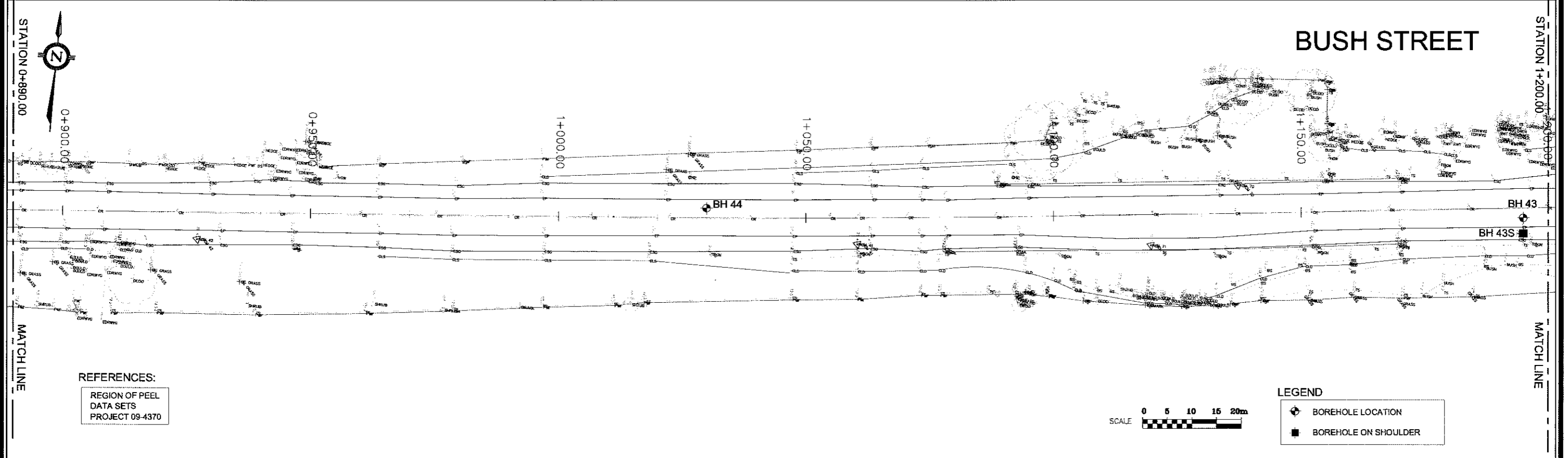
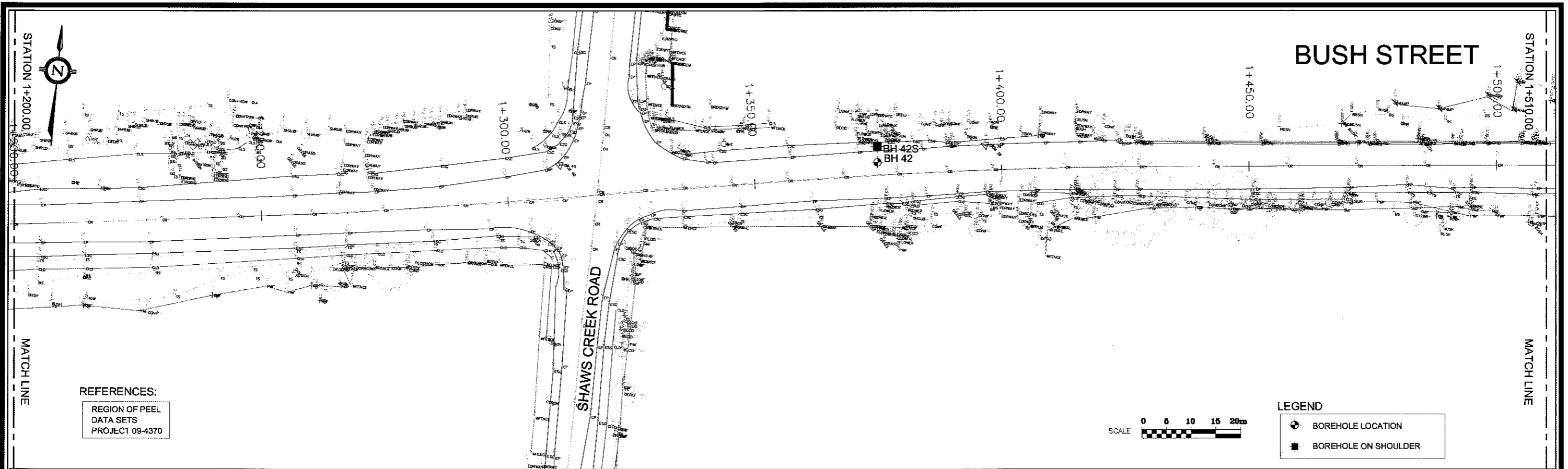
**BOREHOLE LOCATION PLAN**

\\terraprobe\server\terraprobe\_limited\1-10-5056 to 5056\1-10-5056\1-10-5056 Road Adjustment\_Mississauga Rd\_venduz2.rvt.dwg (REV)



**BOREHOLE LOCATION PLAN**

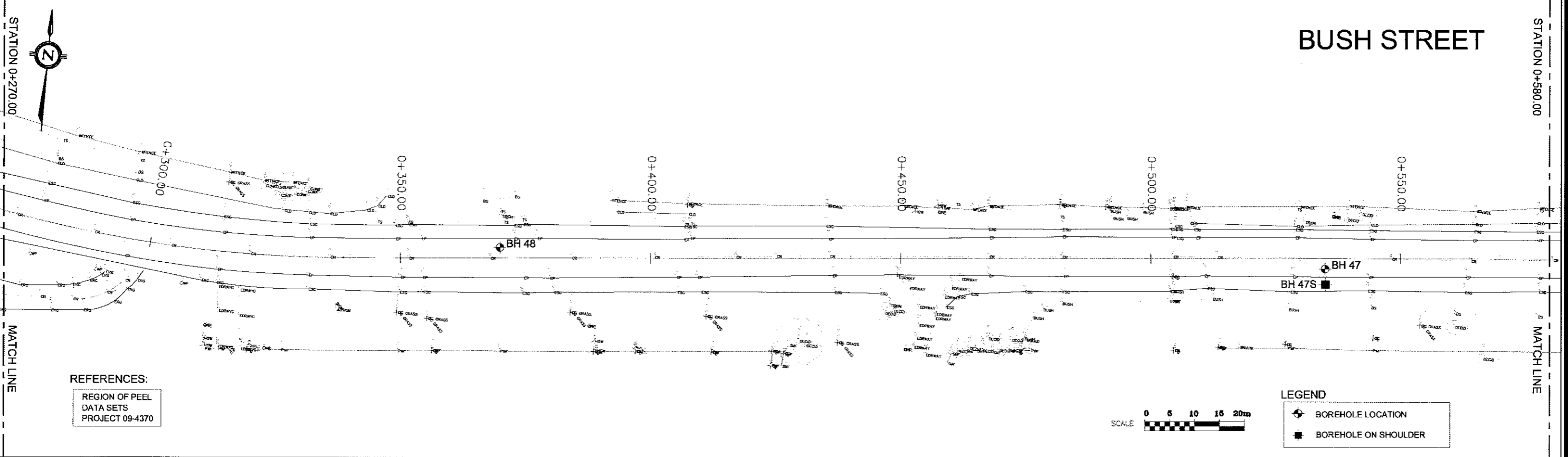
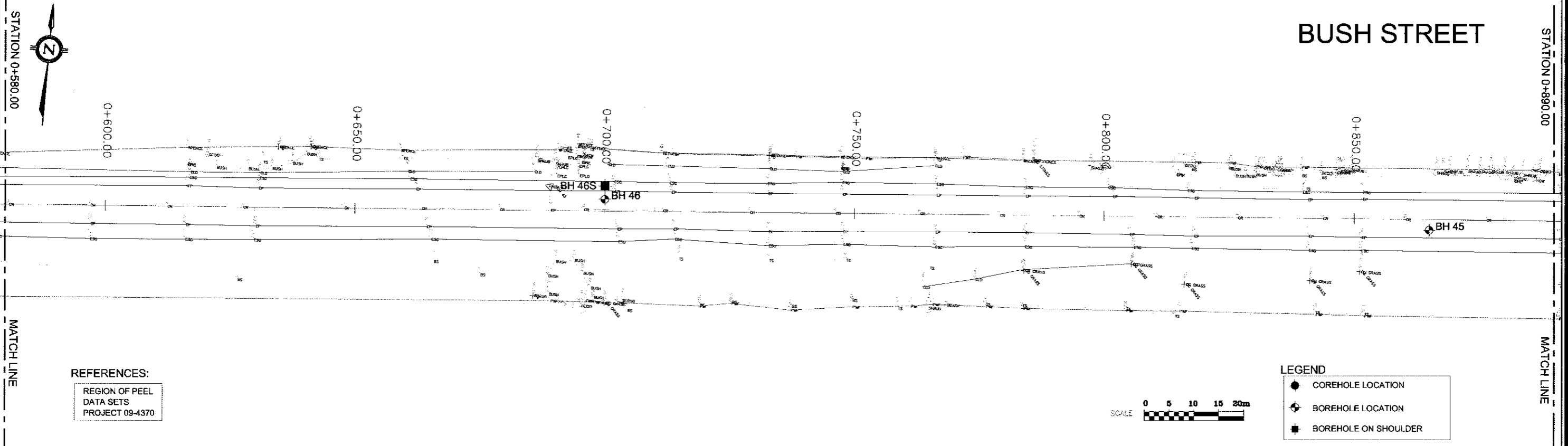
I:\Veridata\Veriserve\Terraprobe\_Umbraco\Projects\2010\_Files\1-10-5056\_Road\_Adjustment\_Bush\_Road\Map\_Rev01.dwg



**BOREHOLE LOCATION PLAN**

I:\Projects\2010\Projects\2010\1-10-5056\1-10-5056\Road Adjustments\Bush Road\Map\REVISION





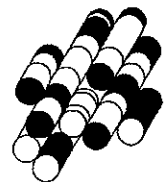
### BOREHOLE LOCATION PLAN

\\terradocs\server\Terraprobe\Linmark\1\Projects\2010 Files\1-10-5056\1-10-5056\A\_Dwg\Map\Map001-10-5056\_Road\_Adjustment\_Bush\_Street.dwg, MEL/N



# APPENDICES

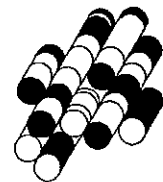
**Terraprobe Inc.**



# **APPENDIX A**

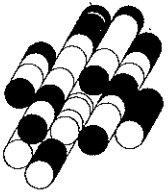
## **Record of Borehole Sheets and Granular Thickness Data**

**Terraprobe Inc.**



**BOREHOLE LOGS**

<b>SAMPLING METHOD</b>  SS split spoon ST Shelby tube AS auger sample WS wash sample RC rock core  WH weight of hammer PH pressure, hydraulic		<b>PENETRATION RESISTANCE</b>  <b>Standard Penetration Test (SPT) resistance ('N' values)</b> is defined as the number of blows by a hammer weighing 63.6 kg (140 lb.) falling freely for a distance of 0.76 m (30 in.) required to advance a standard 50 mm (2 in.) diameter split spoon sampler for a distance of 0.3 m (12 in.).  <b>Dynamic Cone Test (DCT) resistance</b> is defined as the number of blows by a hammer weighing 63.6 kg (140 lb.) falling freely for a distance of 0.76 m (30 in.) required to advance a conical steel point of 50 mm (2 in.) diameter and with 60° sides on 'A' size drill rods for a distance of 0.3 m (12 in.).																																			
<b>SOIL DESCRIPTION - COHESIONLESS SOILS</b>  <table border="1"> <thead> <tr> <th>Relative Density</th> <th>'N' value</th> </tr> </thead> <tbody> <tr> <td>very loose</td> <td>&lt; 4</td> </tr> <tr> <td>loose</td> <td>4 - 10</td> </tr> <tr> <td>compact</td> <td>10 - 30</td> </tr> <tr> <td>dense</td> <td>30 - 50</td> </tr> <tr> <td>very dense</td> <td>&gt; 50</td> </tr> </tbody> </table>		Relative Density	'N' value	very loose	< 4	loose	4 - 10	compact	10 - 30	dense	30 - 50	very dense	> 50	<b>SOIL DESCRIPTION - COHESIVE SOILS</b>  <table border="1"> <thead> <tr> <th>Consistency</th> <th>Undrained Shear Strength, kPa</th> <th>'N' value</th> </tr> </thead> <tbody> <tr> <td>very soft</td> <td>&lt; 12</td> <td>&lt; 2</td> </tr> <tr> <td>soft</td> <td>12 - 25</td> <td>2 - 4</td> </tr> <tr> <td>firm</td> <td>25 - 50</td> <td>4 - 8</td> </tr> <tr> <td>stiff</td> <td>50 - 100</td> <td>8 - 15</td> </tr> <tr> <td>very stiff</td> <td>100 - 200</td> <td>15 - 30</td> </tr> <tr> <td>hard</td> <td>&gt; 200</td> <td>&gt; 30</td> </tr> </tbody> </table>			Consistency	Undrained Shear Strength, kPa	'N' value	very soft	< 12	< 2	soft	12 - 25	2 - 4	firm	25 - 50	4 - 8	stiff	50 - 100	8 - 15	very stiff	100 - 200	15 - 30	hard	> 200	> 30
Relative Density	'N' value																																				
very loose	< 4																																				
loose	4 - 10																																				
compact	10 - 30																																				
dense	30 - 50																																				
very dense	> 50																																				
Consistency	Undrained Shear Strength, kPa	'N' value																																			
very soft	< 12	< 2																																			
soft	12 - 25	2 - 4																																			
firm	25 - 50	4 - 8																																			
stiff	50 - 100	8 - 15																																			
very stiff	100 - 200	15 - 30																																			
hard	> 200	> 30																																			
<b>SOIL COMPOSITION</b>  <table border="1"> <thead> <tr> <th></th> <th>% by weight</th> </tr> </thead> <tbody> <tr> <td>'trace' (e.g. trace silt)</td> <td>&lt; 10</td> </tr> <tr> <td>'some' (e.g. some gravel)</td> <td>10 - 20</td> </tr> <tr> <td>adjective (e.g. sandy)</td> <td>20 - 35</td> </tr> <tr> <td>'and' (e.g. sand and gravel)</td> <td>35 - 50</td> </tr> </tbody> </table>			% by weight	'trace' (e.g. trace silt)	< 10	'some' (e.g. some gravel)	10 - 20	adjective (e.g. sandy)	20 - 35	'and' (e.g. sand and gravel)	35 - 50	<b>TESTS, SYMBOLS</b>  MH mechanical sieve and hydrometer analysis w, w <sub>c</sub> water content w <sub>l</sub> liquid limit w <sub>p</sub> plastic limit I <sub>p</sub> plasticity index k coefficient of permeability γ soil unit weight, bulk φ' angle of internal friction c' cohesion shear strength C <sub>c</sub> compression index																									
	% by weight																																				
'trace' (e.g. trace silt)	< 10																																				
'some' (e.g. some gravel)	10 - 20																																				
adjective (e.g. sandy)	20 - 35																																				
'and' (e.g. sand and gravel)	35 - 50																																				
<b>GENERAL INFORMATION, LIMITATIONS</b>																																					
<p>The conclusions and recommendations provided in this report are based on the factual information obtained from the boreholes and/or test pits. Subsurface conditions between the test holes may vary.</p> <p>The engineering interpretation and report recommendations are given only for the specific project detailed within, and only for the original client. Any third party decision, reliance, or use of this report is the sole and exclusive responsibility of such third party. The number and siting of boreholes and/or test pits may not be sufficient to determine all factors required for different purposes.</p> <p>It is recommended Terraprobe be retained to review the project final design and to provide construction inspection and testing.</p>																																					



# Terraprobe

# LOG OF BOREHOLE 1

PROJECT: Bush Street and Mississauga Road, from  
Winston Churchill Boulevard to Olde Base Line Road

DATE: June 10, 2010

LOCATION: Caledon, Ontario

EQUIPMENT: Solid Stem Augers

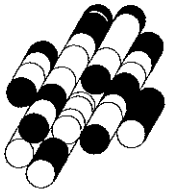
CLIENT: Dillon Consulting Limited

ELEVATION DATUM: n/a

FILE: 1-10-5056

ELEV DEPTH	SOIL PROFILE DESCRIPTION	STRAT PLOT	SAMPLES			ELEVATION SCALE	PENETRATION RESISTANCE PLOT					PLASTIC LIMIT w <sub>p</sub>	NATURAL MOISTURE CONTENT w	LIQUID LIMIT w <sub>L</sub>	ORGANIC VAPOUR (ppm)	STANDPIPE INSTALLATION OR REMARKS
			NUMBER	TYPE	"N" VALUES		20	40	60	80	100					
0.0	Ground Surface 150mm ASPHALT															
0.2	560mm FILL - Sand and Gravel, trace silt, very dense, brown, damp		1	SS	56											
0.7	SILTY SAND some gravel, very dense, brown, damp		2	SS	50/ 8cm											
1.5	End of Borehole		3	SS	50/ 15cm											

NOTES:  
Borehole was dry (not stabilized) and hole open to full depth on completion.



# Terraprobe

# LOG OF BOREHOLE 2

PROJECT: Bush Street and Mississauga Road, from  
Winston Churchill Boulevard to Olde Base Line Road

LOCATION: Caledon, Ontario

CLIENT: Dillon Consulting Limited

DATE: June 07, 2010

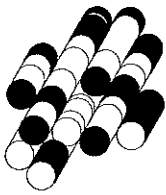
EQUIPMENT: Solid Stem Augers

ELEVATION DATUM: n/a

FILE: 1-10-5056

SOIL PROFILE			SAMPLES			ELEVATION SCALE	PENETRATION RESISTANCE PLOT 20 40 60 80 100	SHEAR STRENGTH kPa 20 40 60 80 100	PLASTIC LIMIT w <sub>p</sub>	NATURAL MOISTURE CONTENT w	LIQUID LIMIT w <sub>L</sub>	ORGANIC VAPOUR (ppm)	STANDPIPE INSTALLATION OR REMARKS
ELEV DEPTH	DESCRIPTION	STRAT PLOT	NUMBER	TYPE	"N" VALUES								
0.0	Ground Surface 180mm ASPHALT	[Solid black box]											
0.2	450mm FILL - Sand and Gravel, trace silt, very dense, brown, damp	[Cross-hatched box]	1	SS	56		GR SA. SI & CL 36 56 . 8		o				
0.6	FILL - Silty Clay, trace sand, trace gravel, hard, brown, damp to moist	[Cross-hatched box]	2	SS	32					o			
1.2	SILTY SAND - some gravel, very dense, brown, damp	[Vertical lines box]	3	SS	50/ 13cm				o				
1.5	End of Borehole												

**NOTES:**  
Borehole was dry (not stabilized) and hole open to full depth on completion.



# Terraprobe

# LOG OF BOREHOLE 3

PROJECT: Bush Street and Mississauga Road, from  
Winston Churchill Boulevard to Olde Base Line Road

LOCATION: Caledon, Ontario

CLIENT: Dillon Consulting Limited

DATE: June 10, 2010

EQUIPMENT: Solid Stem Augers

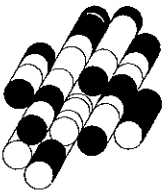
ELEVATION DATUM: n/a

FILE: 1-10-5056

ELEV DEPTH	SOIL PROFILE DESCRIPTION	STRAT PLOT	SAMPLES			ELEVATION SCALE	PENETRATION RESISTANCE PLOT					PLASTIC LIMIT w <sub>p</sub>	NATURAL MOISTURE CONTENT w	LIQUID LIMIT w <sub>L</sub>	ORGANIC VAPOUR (ppm)	STANDPIPE INSTALLATION OR REMARKS
			NUMBER	TYPE	"N" VALUES		SHEAR STRENGTH kPa									
0.0	Ground Surface 150mm ASPHALT															
0.2	560mm FILL - Sand, some gravel, trace silt, very dense, brown, damp		1	SS	90/ 28cm											
0.7	SILTY SAND gravelly, trace clay, compact, brown, dry		2	SS	23											
			3	SS	18											
2.0	End of Borehole															

NOTES:  
Borehole was dry (not stabilized) and hole open to full depth on completion.





# Terraprobe

# LOG OF BOREHOLE 4

PROJECT: Bush Street and Mississauga Road, from  
Winston Churchill Boulevard to Olde Base Line Road

LOCATION: Caledon, Ontario

CLIENT: Dillon Consulting Limited

DATE: June 07, 2010

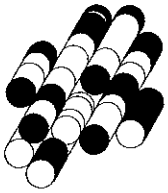
EQUIPMENT: Solid Stem Augers

ELEVATION DATUM: n/a

FILE: 1-10-5056

SOIL PROFILE		SAMPLES			PENETRATION RESISTANCE PLOT	PLASTIC LIMIT	NATURAL MOISTURE CONTENT	LIQUID LIMIT	ORGANIC VAPOUR (ppm)	STANDPIPE INSTALLATION OR REMARKS
ELEV DEPTH	DESCRIPTION	STRAT PLOT	NUMBER	TYPE						
0.0	Ground Surface 240mm ASPHALT									
0.2	480mm FILL - Sand and Gravel, trace silt, dense, brown, damp		1	SS	34					
0.7	SANDY SILT trace clay, trace gravel, compact, brown, wet		2	SS	11					
			3	SS	30					
2.0	End of Borehole									

**NOTES:**  
Borehole was dry (not stabilized) and hole open to full depth on completion.



# Terraprobe

# LOG OF BOREHOLE 5

PROJECT: Bush Street and Mississauga Road, from  
Winston Churchill Boulevard to Olde Base Line Road

DATE: June 10, 2010

LOCATION: Caledon, Ontario

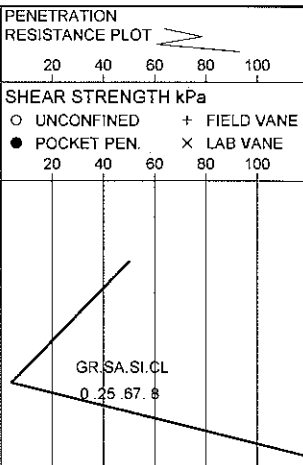
EQUIPMENT: Solid Stem Augers

CLIENT: Dillon Consulting Limited

ELEVATION DATUM: n/a

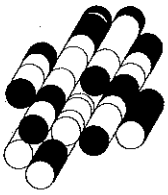
FILE: 1-10-5056

ELEV DEPTH	SOIL PROFILE DESCRIPTION	STRAT PLOT	SAMPLES			ELEVATION SCALE	PENETRATION RESISTANCE PLOT	PLASTIC LIMIT W <sub>p</sub>	NATURAL MOISTURE CONTENT w	LIQUID LIMIT W <sub>L</sub>	ORGANIC VAPOUR (ppm)	STANDPIPE INSTALLATION OR REMARKS
			NUMBER	TYPE	"N" VALUES							
0.0	Ground Surface 240mm ASPHALT											
0.2	180mm FILL - Sand and Gravel, trace silt, very dense, brown, damp		1	SS	50							
0.4	FILL - Sandy Silt, some clay, trace gravel, dense, dark brown, wet											
0.6	SANDY SILT trace clay, occasional cobbles, loose to very dense, brown, moist to wet		2	SS	4							
			3	SS	50/ 2.5cm							
1.5	End of Borehole											



**NOTES:**

Borehole was dry (not stabilized) and hole open to full depth on completion.



# Terraprobe

# LOG OF BOREHOLE 6

PROJECT: Bush Street and Mississauga Road, from  
Winston Churchill Boulevard to Olde Base Line Road

DATE: June 07, 2010

LOCATION: Caledon, Ontario

EQUIPMENT: Solid Stem Augers

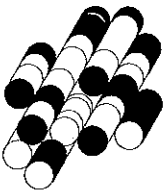
CLIENT: Dillon Consulting Limited

ELEVATION DATUM: n/a

FILE: 1-10-5056

SOIL PROFILE		STRAT PLOT	SAMPLES		ELEVATION SCALE	PENETRATION RESISTANCE PLOT					PLASTIC LIMIT W <sub>p</sub>	NATURAL MOISTURE CONTENT w	LIQUID LIMIT W <sub>L</sub>	ORGANIC VAPOUR (ppm)	STANDPIPE INSTALLATION OR REMARKS
ELEV DEPTH	DESCRIPTION		NUMBER	TYPE		"N" VALUES	20	40	60	80					
0.0	Ground Surface 230mm ASPHALT														
0.2	470mm FILL - Sand and Gravel, trace silt, compact, brown, damp		1	SS	28										
0.7	SILTY SAND some gravel, trace clay, loose to very dense, brown, wet		2	SS	8										
			3	SS	50/ 8cm										
1.6	End of Borehole														

NOTES:  
Water level at 0.8m (not stabilized) and hole open to 1.2m on completion.

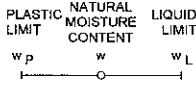
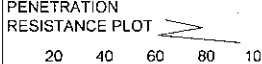


# Terraprobe

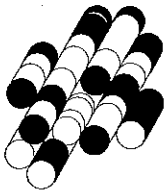
# LOG OF BOREHOLE 7A

PROJECT: Bush Street and Mississauga Road, from Winston Churchill Boulevard to Olde Base Line Road  
 DATE: June 10, 2010  
 LOCATION: Caledon, Ontario  
 EQUIPMENT: Solid Stem Augers  
 CLIENT: Dillon Consulting Limited  
 ELEVATION DATUM: n/a  
 FILE: 1-10-5056

SOIL PROFILE			SAMPLES			PENETRATION RESISTANCE PLOT	PLASTIC LIMIT NATURAL MOISTURE CONTENT LIQUID LIMIT	ORGANIC VAPOUR (ppm)	STANDPIPE INSTALLATION OR REMARKS
ELEV DEPTH	DESCRIPTION	STRAT PLOT	NUMBER	TYPE	"N" VALUES				
0.0	Ground Surface 150mm ASPHALT	[Solid black box]							
0.2	510mm FILL - Sand and Gravel, trace silt, very dense, grey, damp	[Cross-hatched box]	1	SS	56				
0.7	SILTY SAND some gravel, trace clay, compact, brown, moist to wet	[Dotted box]	2	SS	25				
			3	SS	12				
2.0			End of Borehole						



**NOTES:**  
 Water level at 0.6m (not stabilized) and hole open to 0.9m on completion.



# Terraprobe

# LOG OF BOREHOLE 7B

PROJECT: Bush Street and Mississauga Road, from  
Winston Churchill Boulevard to Olde Base Line Road

DATE: June 10, 2010

LOCATION: Caledon, Ontario

EQUIPMENT: Solid Stem Augers

CLIENT: Dillon Consulting Limited

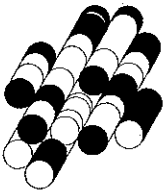
ELEVATION DATUM: n/a

FILE: 1-10-5056

ELEV DEPTH	SOIL PROFILE DESCRIPTION	STRAT PLOT	SAMPLES		ELEVATION SCALE	PENETRATION RESISTANCE PLOT					PLASTIC LIMIT W <sub>P</sub>	NATURAL MOISTURE CONTENT W	LIQUID LIMIT W <sub>L</sub>	ORGANIC VAPOUR (ppm)	STANDPIPE INSTALLATION OR REMARKS
			NUMBER	TYPE		"N" VALUES	SHEAR STRENGTH kPa								
						20	40	60	80	100					
0.0	Ground Surface 230mm ASPHALT														
0.2	340mm FILL - Sand and Gravel, trace silt, very dense, grey, damp		1	SS	50/ 10cm										
0.6	FILL - Clayey Silt, some sand, trace gravel, hard, grey, moist		2	SS	50/ 15cm										
0.9	SILTY SAND some gravel, brown, damp														
1.4	End of Borehole		3	SS	50/ 0cm										

**NOTES:**

Borehole was dry (not stabilized) and hole open to full depth on completion.



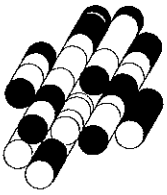
# Terraprobe

# LOG OF BOREHOLE 8

PROJECT: Bush Street and Mississauga Road, from Winston Churchill Boulevard to Olde Base Line Road DATE: June 07, 2010  
 LOCATION: Caledon, Ontario EQUIPMENT: Solid Stem Augers  
 CLIENT: Dillon Consulting Limited ELEVATION DATUM: n/a FILE: 1-10-5056

ELEV DEPTH	SOIL PROFILE DESCRIPTION	STRAT PLOT	SAMPLES			ELEVATION SCALE	PENETRATION RESISTANCE PLOT		PLASTIC LIMIT w <sub>p</sub>	NATURAL MOISTURE CONTENT w	LIQUID LIMIT w <sub>L</sub>	ORGANIC VAPOUR (ppm)	STANDPIPE INSTALLATION OR REMARKS
			NUMBER	TYPE	'N' VALUES		20	40					
0.0	Ground Surface 170mm ASPHALT												
0.2	110mm FILL - Sand and Gravel, trace silt, compact, brown, damp		1	SS	29								
0.3	FILL - Sandy Silt, some clay, compact, brown, wet		2	SS	50/ 8cm								
0.8	SILTY SAND some gravel, occasional cobbles, very dense, brown, damp		3	SS	50/ 0cm								
1.4	End of Borehole												

NOTES:  
Borehole was dry (not stabilized) and hole open to full depth on completion.



# Terraprobe

# LOG OF BOREHOLE 9

PROJECT: Bush Street and Mississauga Road, from  
Winston Churchill Boulevard to Olde Base Line Road

LOCATION: Caledon, Ontario

CLIENT: Dillon Consulting Limited

DATE: June 10, 2010

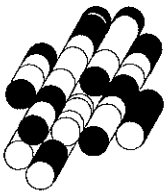
EQUIPMENT: Solid Stem Augers

ELEVATION DATUM: n/a

FILE: 1-10-5056

SOIL PROFILE		STRAT PLOT	SAMPLES		ELEVATION SCALE	PENETRATION RESISTANCE PLOT					PLASTIC LIMIT w <sub>p</sub>	NATURAL MOISTURE CONTENT w	LIQUID LIMIT w <sub>L</sub>	ORGANIC VAPOUR (ppm)	STANDPIPE INSTALLATION OR REMARKS
ELEV DEPTH	DESCRIPTION		NUMBER	TYPE		"N" VALUES	SHEAR STRENGTH kPa								
						20	40	60	80	100					
0.0	Ground Surface 250mm ASPHALT														
0.3	140mm FILL - Sand and Gravel, trace silt, very dense, brown, damp		1	SS	50										
0.4	SILTY SAND trace to some gravel, occasional cobbles, very dense, brown, damp		2	SS	50/ 0cm										
1.4	End of Borehole		3	SS	50/ 0cm										

**NOTES:**  
Borehole was dry (not stabilized) and hole open to full depth on completion.



# Terraprobe

# LOG OF BOREHOLE 10

PROJECT: Bush Street and Mississauga Road, from  
Winston Churchill Boulevard to Olde Base Line Road

LOCATION: Caledon, Ontario

CLIENT: Dillon Consulting Limited

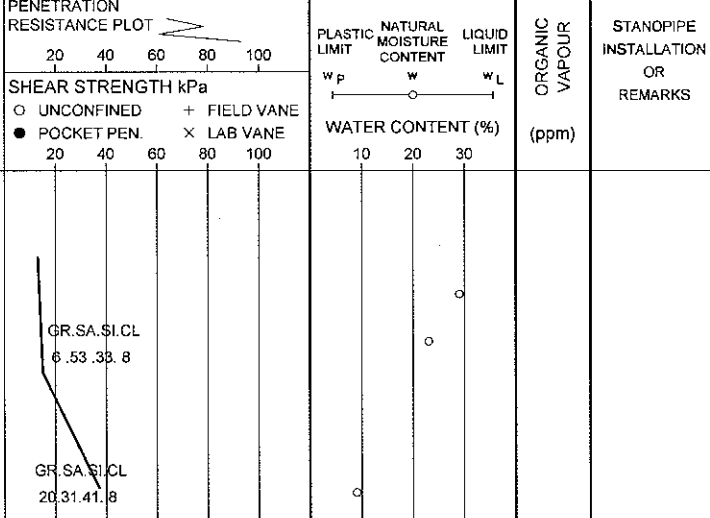
DATE: June 07, 2010

EQUIPMENT: Solid Stem Augers

ELEVATION DATUM: n/a

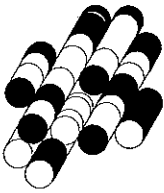
FILE: 1-10-5056

SOIL PROFILE		SAMPLES			PENETRATION RESISTANCE PLOT	PLASTIC LIMIT	NATURAL MOISTURE CONTENT	LIQUID LIMIT	ORGANIC VAPOUR	STANOPIPE INSTALLATION OR REMARKS
ELEV DEPTH	DESCRIPTION	STRAT PLOT	NUMBER	TYPE						
0.0	Ground Surface 150mm ASPHALT	[Solid Black]								
0.2	450mm FILL - Sand and Gravel, trace silt, compact, brown, damp	[Cross-hatch]	1	SS	13					
0.6	FILL - Silty Sand, trace clay, trace gravel, compact, dark brown, wet	[Cross-hatch]	2	SS	15					
1.1	SANDY SILT some gravel, trace clay, compact to dense, brown, damp to moist	[Dotted]	3	SS	37					
2.0	End of Borehole									



**NOTES:**  
Borehole was dry (not stabilized) and hole open to full depth on completion.





# Terraprobe

# LOG OF BOREHOLE 11

PROJECT: Bush Street and Mississauga Road, from  
Winston Churchill Boulevard to Olde Base Line Road

DATE: June 10, 2010

LOCATION: Caledon, Ontario

EQUIPMENT: Solid Stem Augers

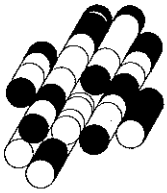
CLIENT: Dillon Consulting Limited

ELEVATION DATUM: n/a

FILE: 1-10-5056

SOIL PROFILE		SAMPLES			ELEVATION SCALE	PENETRATION RESISTANCE PLOT	PLASTIC LIMIT W <sub>p</sub>	NATURAL MOISTURE CONTENT W	LIQUID LIMIT W <sub>L</sub>	ORGANIC VAPOUR (ppm)	STANDPIPE INSTALLATION OR REMARKS
ELEV DEPTH	DESCRIPTION	STRAT PLOT	NUMBER	TYPE							
0.0	Ground Surface 300mm ASPHALT										
0.3	300mm FILL - Sand and Gravel, trace silt, dense, brown, damp		1	SS	36						
0.6	FILL - Sandy Silt, some clay, trace gravel, dense, dark brown, wet		2	SS	7						
0.8	SANDY SILT trace clay, trace gravel, loose to compact, brown, wet		3	SS	12						
2.0	End of Borehole										

**NOTES:**  
Borehole was dry (not stabilized) and hole open to full depth on completion.



# Terraprobe

# LOG OF BOREHOLE 12

PROJECT: Bush Street and Mississauga Road, from  
Winston Churchill Boulevard to Olde Base Line Road

DATE: June 07, 2010

LOCATION: Caledon, Ontario

EQUIPMENT: Solid Stem Augers

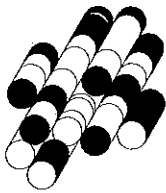
CLIENT: Dillon Consulting Limited

ELEVATION DATUM: n/a

FILE: 1-10-5056

SOIL PROFILE			SAMPLES			ELEVATION SCALE	PENETRATION RESISTANCE PLOT					PLASTIC LIMIT w <sub>p</sub>	NATURAL MOISTURE CONTENT w	LIQUID LIMIT w <sub>L</sub>	ORGANIC VAPOUR (ppm)	STANDPIPE INSTALLATION OR REMARKS
ELEV DEPTH	DESCRIPTION	STRAT PLOT	NUMBER	TYPE	"N" VALUES		SHEAR STRENGTH kPa									
						20	40	60	80	100						
0.0	Ground Surface 150mm ASPHALT															
0.2	500mm FILL - Sand and Gravel, trace silt, compact, brown, damp		1	SS	25											
0.7	SANDY SILT some clay, trace gravel, compact, brown, wet		2	SS	22											
			3	SS	12											
2.0			End of Borehole													

NOTES:  
Borehole was dry (not stabilized) and hole open to full depth on completion.



# Terraprobe

# LOG OF BOREHOLE 13

PROJECT: Bush Street and Mississauga Road, from  
Winston Churchill Boulevard to Olde Base Line Road

DATE: June 10, 2010

LOCATION: Caledon, Ontario

EQUIPMENT: Solid Stem Augers

CLIENT: Dillon Consulting Limited

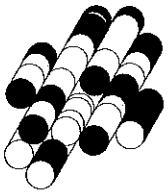
ELEVATION DATUM: n/a

FILE: 1-10-5056

ELEV DEPTH	SOIL PROFILE DESCRIPTION	STRAT PLOT	SAMPLES			ELEVATION SCALE	PENETRATION RESISTANCE PLOT					PLASTIC LIMIT w <sub>p</sub>	NATURAL MOISTURE CONTENT w	LIQUID LIMIT w <sub>L</sub>	ORGANIC VAPOUR (ppm)	STANDPIPE INSTALLATION OR REMARKS
			NUMBER	TYPE	"N" VALUES		20	40	60	80	100					
0.0	Ground Surface 250mm ASPHALT															
0.3	350mm FILL - Sand and Gravel, trace silt, compact, brown, damp		1	SS	14											
0.6	FILL - Clayey Silt, trace sand, trace gravel, stiff, black, moist															
0.8	SILTY CLAY some sand, trace gravel, stiff to very stiff, brown, damp to moist		2	SS	13											
			3	SS	19											
2.0	End of Borehole															

**NOTES:**

Borehole was dry (not stabilized) and hole open to full depth on completion.



# Terraprobe

# LOG OF BOREHOLE 14

PROJECT: Bush Street and Mississauga Road, from  
Winston Churchill Boulevard to Olde Base Line Road

DATE: June 07, 2010

LOCATION: Caledon, Ontario

EQUIPMENT: Solid Stem Augers

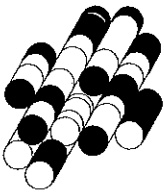
CLIENT: Dillon Consulting Limited

ELEVATION DATUM: n/a

FILE: 1-10-5056

ELEV DEPTH	SOIL PROFILE DESCRIPTION	STRAT PLOT	SAMPLES			ELEVATION SCALE	PENETRATION RESISTANCE PLOT					PLASTIC LIMIT w <sub>p</sub>	NATURAL MOISTURE CONTENT w	LIQUID LIMIT w <sub>L</sub>	ORGANIC VAPOUR (ppm)	STANDPIPE INSTALLATION OR REMARKS
			NUMBER	TYPE	"N" VALUES		SHEAR STRENGTH kPa									
							20	40	60	80	100					
0.0	Ground Surface 230mm ASPHALT															
0.2	370mm FILL - Sand and Gravel, trace silt, dense, brown, damp		1	SS	34											
0.6	SANDY SILT some clay, trace gravel, compact, brown, wet		2	SS	23											
			3	SS	25											
2.0	End of Borehole															

NOTES:  
Borehole was dry (not stabilized) and hole open to full depth on completion.



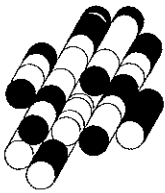
# Terraprobe

# LOG OF BOREHOLE 15

PROJECT: Bush Street and Mississauga Road, from Winston Churchill Boulevard to Olde Base Line Road      DATE: June 10, 2010  
 LOCATION: Caledon, Ontario      EQUIPMENT: Solid Stem Augers  
 CLIENT: Dillon Consulting Limited      ELEVATION DATUM: n/a      FILE: 1-10-5056

SOIL PROFILE		STRAT PLOT	SAMPLES		ELEVATION SCALE	PENETRATION RESISTANCE PLOT 20 40 60 80 100	PLASTIC LIMIT NATURAL MOISTURE CONTENT LIQUID LIMIT W <sub>p</sub> — W — W <sub>L</sub>	ORGANIC VAPOUR (ppm)	STANDPIPE INSTALLATION OR REMARKS
ELEV DEPTH	DESCRIPTION		NUMBER	TYPE					
0.0	Ground Surface 250mm ASPHALT								
0.3	370mm FILL - Sandy Gravel, trace silt, very dense, brown, damp to moist		1	SS	66/ 20cm	GR.SA.SI&CL 59.32.9	○		
0.6	FILL - Sandy Silt, some gravel, trace clay, occasional cobbles, trace rootlets below 1.4m, compact, brown, wet		2	SS	50/ 0cm		○		▽
			3	SS	23			○	
2.0	End of Borehole								

**NOTES:**  
 Water level at 0.9m (not stabilized) and hole open to full depth on completion.

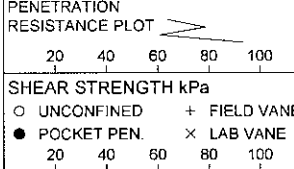


# Terraprobe

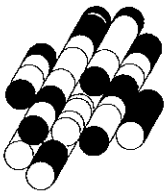
# LOG OF BOREHOLE 16

PROJECT: Bush Street and Mississauga Road, from Winston Churchill Boulevard to Olde Base Line Road      DATE: June 07, 2010  
 LOCATION: Caledon, Ontario      EQUIPMENT: Solid Stem Augers  
 CLIENT: Dillon Consulting Limited      ELEVATION DATUM: n/a      FILE: 1-10-5056

SOIL PROFILE		STRAT PLOT	SAMPLES			ELEVATION SCALE	PENETRATION RESISTANCE PLOT	PLASTIC LIMIT W <sub>P</sub>	NATURAL MOISTURE CONTENT W	LIQUID LIMIT W <sub>L</sub>	ORGANIC VAPOUR (ppm)	STANOPIPE INSTALLATION OR REMARKS
ELEV DEPTH	DESCRIPTION		NUMBER	TYPE	"N" VALUES							
0.0	Ground Surface 250mm ASPHALT											
0.3	460mm FILL - Sand and Gravel, trace silt, very dense, brown, damp		1	SS	50/ 15cm							
0.7	SILTY SAND gravelly, trace clay, compact to very dense, brown, moist to wet		2	SS	23							
			3	SS	83							
1.8	End of Borehole											



**NOTES:**  
 Borehole was dry (not stabilized) and hole open to full depth on completion.



# Terraprobe

# LOG OF BOREHOLE 17

PROJECT: Bush Street and Mississauga Road, from  
Winston Churchill Boulevard to Olde Base Line Road

LOCATION: Caledon, Ontario

CLIENT: Dillon Consulting Limited

DATE: June 10, 2010

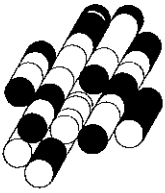
EQUIPMENT: Solid Stem Augers

ELEVATION DATUM: n/a

FILE: 1-10-5056

ELEV DEPTH	SOIL PROFILE DESCRIPTION	STRAT PLOT	SAMPLES			ELEVATION SCALE	PENETRATION RESISTANCE PLOT					PLASTIC LIMIT w <sub>p</sub>	NATURAL MOISTURE CONTENT w	LIQUID LIMIT w <sub>L</sub>	ORGANIC VAPOUR (ppm)	STANDPIPE INSTALLATION OR REMARKS
			NUMBER	TYPE	"N" VALUES		SHEAR STRENGTH kPa									
							20	40	60	80	100					
0.0	Ground Surface 200mm ASPHALT															
0.2	270mm FILL - Sand and Gravel, trace silt, compact, brown, damp		1	SS	27											
0.5	SILTY SAND trace to some gravel, compact to very dense, brown, moist to wet		2	SS	24											
			3	SS	54											
1.9	End of Borehole															

NOTES:  
Borehole was dry (not stabilized) and hole open to full depth on completion.



# Terraprobe

# LOG OF BOREHOLE 18

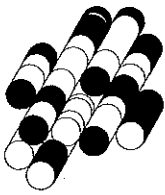
PROJECT: Bush Street and Mississauga Road, from Winston Churchill Boulevard to Olde Base Line Road  
 DATE: June 07, 2010  
 LOCATION: Caledon, Ontario  
 EQUIPMENT: Solid Stem Augers  
 CLIENT: Dillon Consulting Limited  
 ELEVATION DATUM: n/a  
 FILE: 1-10-5056

ELEV DEPTH	SOIL PROFILE DESCRIPTION	STRAT PLOT	SAMPLES			ELEVATION SCALE	PENETRATION RESISTANCE PLOT					PLASTIC LIMIT w <sub>p</sub>	NATURAL MOISTURE CONTENT w	LIQUID LIMIT w <sub>L</sub>	ORGANIC VAPOUR (ppm)	STANDPIPE INSTALLATION OR REMARKS
			NUMBER	TYPE	"N" VALUES		20	40	60	80	100					
0.0	Ground Surface 210mm ASPHALT															
0.2	450mm FILL - Sand and Gravel, trace silt, compact, brown, damp		1	SS	29											
0.7	FILL - Sandy Silt, trace clay, trace gravel, compact, dark brown, wet															
0.8	SANDY SILT trace to some clay, trace gravel, loose to compact, brown, wet		2	SS	13											
			3	SS	7											
2.0	End of Borehole															

GR. SA. SILT  
6 20 64 10

**NOTES:**  
 Borehole was dry (not stabilized) and hole open to full depth on completion.





# Terraprobe

# LOG OF BOREHOLE 19

PROJECT: Bush Street and Mississauga Road, from  
Winston Churchill Boulevard to Olde Base Line Road

DATE: June 10, 2010

LOCATION: Caledon, Ontario

EQUIPMENT: Solid Stem Augers

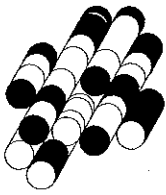
CLIENT: Dillon Consulting Limited

ELEVATION DATUM: n/a

FILE: 1-10-5056

ELEV DEPTH	SOIL PROFILE DESCRIPTION	STRAT PLOT	SAMPLES			ELEVATION SCALE	PENETRATION RESISTANCE PLOT					PLASTIC LIMIT w <sub>p</sub>	NATURAL MOISTURE CONTENT w	LIQUID LIMIT w <sub>L</sub>	ORGANIC VAPOUR (ppm)	STANDPIPE INSTALLATION OR REMARKS
			NUMBER	TYPE	"N" VALUES		SHEAR STRENGTH kPa									
							20	40	60	80	100					
0.0	Ground Surface 130mm ASPHALT															
0.1	500mm FILL - Gravelly Sand, trace silt, very dense, brown, damp		1	SS	62											
0.6	FILL - Sandy Silt, trace to some clay, trace gravel, inferred compact, brown, wet		2	SS	25											
0.8	SANDY SILT trace clay, trace gravel, compact, brown, wet		3	SS	14											
2.0	End of Borehole															

NOTES:  
Borehole was dry (not stabilized) and hole open to full depth on completion.



# Terraprobe

# LOG OF BOREHOLE 20

PROJECT: Bush Street and Mississauga Road, from  
Winston Churchill Boulevard to Olde Base Line Road

DATE: June 07, 2010

LOCATION: Caledon, Ontario

EQUIPMENT: Solid Stem Augers

CLIENT: Dillon Consulting Limited

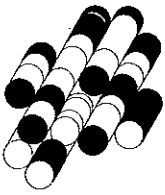
ELEVATION DATUM: n/a

FILE: 1-10-5056

SOIL PROFILE			SAMPLES			PENETRATION RESISTANCE PLOT	PLASTIC LIMIT	NATURAL MOISTURE CONTENT	LIQUID LIMIT	ORGANIC VAPOUR (ppm)	STANDPIPE INSTALLATION OR REMARKS
ELEV DEPTH	DESCRIPTION	STRAT PLOT	NUMBER	TYPE	"N" VALUES						
0.0	Ground Surface 300mm ASPHALT										
0.3	130mm FILL - Sand and Gravel, trace silt, brown, dry		1	SS	50/ 15cm						
0.3	FILL - Sandy Silt, trace clay, trace gravel, trace rootlets below 1.4m, compact to very dense, brown, wet		2	SS	40						
			3	SS	14						
2.0	End of Borehole										

**NOTES:**

Borehole was dry (not stabilized) and hole open to full depth on completion.



# Terraprobe

# LOG OF BOREHOLE 21

PROJECT: Bush Street and Mississauga Road, from  
Winston Churchill Boulevard to Olde Base Line Road

DATE: June 10, 2010

LOCATION: Caledon, Ontario

EQUIPMENT: Solid Stem Augers

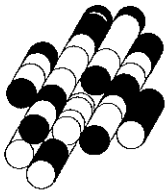
CLIENT: Dillon Consulting Limited

ELEVATION DATUM: n/a

FILE: 1-10-5056

SOIL PROFILE		SAMPLES			ELEVATION SCALE	PENETRATION RESISTANCE PLOT 20 40 60 80 100 SHEAR STRENGTH kPa ○ UNCONFINED + FIELD VANE ● POCKET PEN. × LAB VANE	PLASTIC LIMIT NATURAL MOISTURE CONTENT LIQUID LIMIT w <sub>p</sub> w w <sub>L</sub> WATER CONTENT (%)	ORGANIC VAPOUR (ppm)	STANDPIPE INSTALLATION OR REMARKS
ELEV DEPTH	DESCRIPTION	STRAT PLOT	NUMBER	TYPE					
0.0	Ground Surface 290mm ASPHALT								
0.3	290mm FILL - Gravelly Sand, trace silt, dense, brown, damp		1	SS	40				
0.6	FILL - Sandy Silt, some gravel, trace clay, topsoil stained, loose to dense, black, wet		2	SS	8	6R.SA.SI.CL 12.22.60.6			
1.4	SANDY SILT some clay, trace gravel, compact, brown, wet		3	SS	10				
2.0	End of Borehole								

NOTES:  
Borehole was dry (not stabilized) and hole open to full depth on completion.



# Terraprobe

# LOG OF BOREHOLE 22

PROJECT: Bush Street and Mississauga Road, from  
Winston Churchill Boulevard to Olde Base Line Road

DATE: June 07, 2010

LOCATION: Caledon, Ontario

EQUIPMENT: Solid Stem Augers

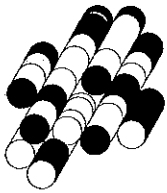
CLIENT: Dillon Consulting Limited

ELEVATION DATUM: n/a

FILE: 1-10-5056

SOIL PROFILE			SAMPLES			ELEVATION SCALE	PENETRATION RESISTANCE PLOT 20 40 60 80 100	SHEAR STRENGTH kPa 20 40 60 80 100	PLASTIC LIMIT W <sub>p</sub>	NATURAL MOISTURE CONTENT w	LIQUID LIMIT W <sub>L</sub>	ORGANIC VAPOUR (ppm)	STANDPIPE INSTALLATION OR REMARKS
ELEV DEPTH	DESCRIPTION	STRAT PLOT	NUMBER	TYPE	"N" VALUES								
0.0	Ground Surface 230mm ASPHALT												
0.2	480mm FILL - Gravelly Sand, trace silt, very dense, brown, damp		1	SS	59								
0.7	damp ----  SILTY SAND trace gravel, compact to very dense, brown, wet		2	SS	50/ 15cm								
			3	SS	14								
2.0	End of Borehole												

NOTES:  
Borehole was dry (not stabilized) and hole open to full depth on completion.



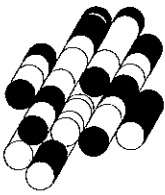
# Terraprobe

# LOG OF BOREHOLE 23

PROJECT: Bush Street and Mississauga Road, from Winston Churchill Boulevard to Olde Base Line Road      DATE: June 10, 2010  
 LOCATION: Caledon, Ontario      EQUIPMENT: Solid Stem Augers  
 CLIENT: Dillon Consulting Limited      ELEVATION DATUM: n/a      FILE: 1-10-5056

SOIL PROFILE		STRAT PLOT	SAMPLES		ELEVATION SCALE	PENETRATION RESISTANCE PLOT					PLASTIC LIMIT W <sub>P</sub>	NATURAL MOISTURE CONTENT W	LIQUID LIMIT W <sub>L</sub>	ORGANIC VAPOUR (ppm)	STANDPIPE INSTALLATION OR REMARKS
ELEV DEPTH	DESCRIPTION		NUMBER	TYPE		"N" VALUES	SHEAR STRENGTH kPa								
0.0	Ground Surface 180mm ASPHALT														
0.2	350mm FILL - Sand and Gravel, trace silt, very dense, brown, damp		1	SS	50/ 15cm										
0.5	SILTY SAND some gravel, occasional cobbles, dense, brown, damp		2	SS	46										
			3	SS	49										
2.0			End of Borehole												

**NOTES:**  
 Borehole was dry (not stabilized) and hole open to full depth on completion.



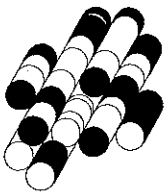
# Terraprobe

# LOG OF BOREHOLE 24

PROJECT: Bush Street and Mississauga Road, from Winston Churchill Boulevard to Olde Base Line Road  
 DATE: June 08, 2010  
 LOCATION: Caledon, Ontario  
 EQUIPMENT: Solid Stem Augers  
 CLIENT: Dillon Consulting Limited  
 ELEVATION DATUM: n/a  
 FILE: 1-10-5056

SOIL PROFILE		STRAT PLOT	SAMPLES		ELEVATION SCALE	PENETRATION RESISTANCE PLOT	PLASTIC LIMIT	NATURAL MOISTURE CONTENT	LIQUID LIMIT	ORGANIC VAPOUR (ppm)	STANDPIPE INSTALLATION OR REMARKS
ELEV DEPTH	DESCRIPTION		NUMBER	TYPE							
0.0	Ground Surface 150mm ASPHALT										
0.2	560mm FILL - Gravelly Sand, trace silt, compact, brown, damp		1	SS	20		○				
0.7	SILTY SAND some gravel, dense to very dense, brown, damp to moist		2	SS	53		○				
			3	SS	42		○				
2.0	End of Borehole										

**NOTES:**  
 Borehole was dry (not stabilized) and hole open to full depth on completion.



# Terraprobe

# LOG OF BOREHOLE 25

PROJECT: Bush Street and Mississauga Road, from  
Winston Churchill Boulevard to Olde Base Line Road

DATE: June 10, 2010

LOCATION: Caledon, Ontario

EQUIPMENT: Solid Stem Augers

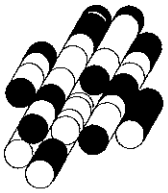
CLIENT: Dillon Consulting Limited

ELEVATION DATUM: n/a

FILE: 1-10-5056

ELEV DEPTH	SOIL PROFILE DESCRIPTION	STRAT PLOT	SAMPLES			ELEVATION SCALE	PENETRATION RESISTANCE PLOT					PLASTIC LIMIT w <sub>p</sub>	NATURAL MOISTURE CONTENT w	LIQUID LIMIT w <sub>L</sub>	ORGANIC VAPOUR (ppm)	STANDPIPE INSTALLATION OR REMARKS
			NUMBER	TYPE	"N" VALUES		SHEAR STRENGTH kPa									
							20	40	60	80	100					
0.0	Ground Surface 170mm ASPHALT															
0.2	240mm FILL - Gravelly Sand, trace silt, compact, brown, damp		1	SS	20											
0.4	FILL - Sandy Silt, some gravel, occasional cobbles, compact to very dense, brown, moist to wet		2	SS	25											
			3	SS	51											
2.0	End of Borehole															

NOTES:  
Borehole was dry (not stabilized) and hole open to full depth on completion.



# Terraprobe

# LOG OF BOREHOLE 26

PROJECT: Bush Street and Mississauga Road, from  
Winston Churchill Boulevard to Olde Base Line Road

DATE: June 08, 2010

LOCATION: Caledon, Ontario

EQUIPMENT: Solid Stem Augers

CLIENT: Dillon Consulting Limited

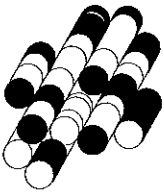
ELEVATION DATUM: n/a

FILE: 1-10-5056

SOIL PROFILE			SAMPLES			ELEVATION SCALE	PENETRATION RESISTANCE PLOT		PLASTIC NATURAL LIQUID LIMIT			ORGANIC VAPOUR (ppm)	STANDPIPE INSTALLATION OR REMARKS
ELEV DEPTH	DESCRIPTION	STRAT PLOT	NUMBER	TYPE	"N" VALUES		20 40 60 80 100	20 40 60 80 100	W <sub>p</sub>	W	W <sub>L</sub>		
0.0	Ground Surface 150mm ASPHALT												
0.2	440mm FILL - Gravelly Sand, trace silt, compact, brown, damp		1	SS	29								
0.6	FILL - Silty Sand, some gravel, compact, brown, moist to wet		2	SS	22								
			3	SS	23								
2.0	End of Borehole												

NOTES:  
Borehole was dry (not stabilized) and hole open to full depth on completion.





# Terraprobe

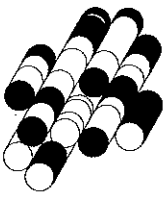
# LOG OF BOREHOLE 27

PROJECT: Bush Street and Mississauga Road, from  
 Winston Churchill Boulevard to Olde Base Line Road  
 LOCATION: Caledon, Ontario  
 CLIENT: Dillon Consulting Limited

DATE: June 08, 2010  
 EQUIPMENT: Solid Stem Augers  
 ELEVATION DATUM: n/a  
 FILE: 1-10-5056

SOIL PROFILE		STRAT PLOT	SAMPLES		ELEVATION SCALE	PENETRATION RESISTANCE PLOT	PLASTIC LIMIT NATURAL MOISTURE CONTENT LIQUID LIMIT	ORGANIC VAPOUR (ppm)	STANDPIPE INSTALLATION OR REMARKS
ELEV DEPTH	DESCRIPTION		NUMBER	TYPE					
0.0	Ground Surface 130mm ASPHALT	[Solid black]							
0.1	400mm FILL - Gravelly Sand, trace silt, dense, brown, damp to moist	[Cross-hatched]	1	SS	48				
0.5	FILL - Silty Sand, trace gravel, dense, brown, damp	[Dotted]							
0.8	SANDY SILT some gravel, trace clay, dense, brown, damp to moist	[Vertical lines]	2	SS	36				
			3	SS	48				
2.0	End of Borehole								

NOTES:  
 Borehole was dry (not stabilized) and hole open to full depth on completion.



# Terraprobe

# LOG OF BOREHOLE 28

PROJECT: Bush Street and Mississauga Road, from  
Winston Churchill Boulevard to Olde Base Line Road

DATE: June 08, 2010

LOCATION: Caledon, Ontario

EQUIPMENT: Solid Stem Augers

CLIENT: Dillon Consulting Limited

ELEVATION DATUM: n/a

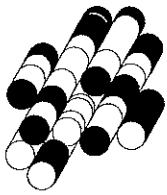
FILE: 1-10-5056

ELEV DEPTH	SOIL PROFILE DESCRIPTION	STRAT PLOT	SAMPLES			ELEVATION SCALE	PENETRATION RESISTANCE PLOT		PLASTIC LIMIT w <sub>p</sub>	NATURAL MOISTURE CONTENT w	LIQUID LIMIT w <sub>L</sub>	ORGANIC VAPOUR (ppm)	STANDPIPE INSTALLATION OR REMARKS
			NUMBER	TYPE	"N" VALUES		20	40					
0.0	Ground Surface 150mm ASPHALT												
0.2	300mm FILL - Sand and Gravel, trace silt, compact, brown, dry		1	SS	11								
0.5	FILL - Sandy Silt, some clay, compact, dark brown, wet		2	SS	12								
	trace organics, loose		3	SS	7								
2.0	End of Borehole												

GR. SA. SILT  
0.33 57.10

**NOTES:**

Borehole was dry (not stabilized) and hole open to full depth on completion.



# Terraprobe

# LOG OF BOREHOLE 29

PROJECT: Bush Street and Mississauga Road, from  
Winston Churchill Boulevard to Olde Base Line Road

LOCATION: Caledon, Ontario

CLIENT: Dillon Consulting Limited

DATE: June 08, 2010

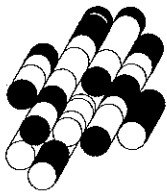
EQUIPMENT: Solid Stem Augers

ELEVATION DATUM: n/a

FILE: 1-10-5056

SOIL PROFILE			SAMPLES			ELEVATION SCALE	PENETRATION RESISTANCE PLOT	PLASTIC LIMIT NATURAL MOISTURE CONTENT LIQUID LIMIT	ORGANIC VAPOUR (ppm)	STANDPIPE INSTALLATION OR REMARKS
ELEV DEPTH	DESCRIPTION	STRAT PLOT	NUMBER	TYPE	"N" VALUES					
0.0	Ground Surface									
0.0	100mm ASPHALT									
0.1	360mm FILL - Sand and Gravel, trace silt, compact, brown, damp		1	SS	12					
0.5	FILL - Sandy Silt, trace gravel, compact, dark brown, wet									
0.8	GRAVELLY SAND some silt, trace clay, very dense, brown, damp		2	SS	53					
			3	SS	76					
2.0	End of Borehole									

**NOTES:**  
Borehole was dry (not stabilized) and hole open to full depth on completion.



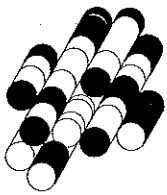
# Terraprobe

# LOG OF BOREHOLE 30

PROJECT: Bush Street and Mississauga Road, from Winston Churchill Boulevard to Olde Base Line Road  
 DATE: June 08, 2010  
 LOCATION: Caledon, Ontario  
 EQUIPMENT: Solid Stem Augers  
 CLIENT: Dillon Consulting Limited  
 ELEVATION DATUM: n/a  
 FILE: 1-10-5056

SOIL PROFILE		SAMPLES			ELEVATION SCALE	PENETRATION RESISTANCE PLOT 20 40 60 80 100	PLASTIC LIMIT W <sub>P</sub>	NATURAL MOISTURE CONTENT W	LIQUID LIMIT W <sub>L</sub>	ORGANIC VAPOUR (ppm)	STANDPIPE INSTALLATION OR REMARKS
ELEV DEPTH	DESCRIPTION	STRAT PLOT	NUMBER	TYPE							
0.0	Ground Surface										
0.1	100mm ASPHALT										
0.3	230mm FILL - Sand and Gravel, trace silt, compact, brown, damp		1	SS	15						
0.8	FILL - Sandy Silt, trace gravel, compact, dark brown, wet										
	GRAVELLY SAND some silt, trace clay, very dense, brown, damp		2	SS	69						
			3	SS	50/ 13cm						
1.7	End of Borehole										

**NOTES:**  
 Borehole was dry (not stabilized) and hole open to full depth on completion.

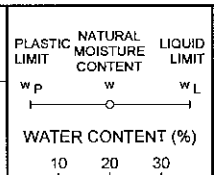
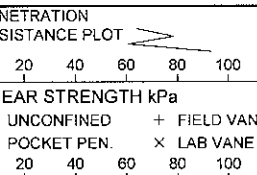


# Terraprobe

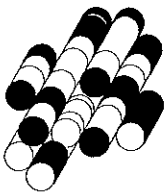
# LOG OF BOREHOLE 31

PROJECT: Bush Street and Mississauga Road, from Winston Churchill Boulevard to Olde Base Line Road  
 DATE: June 08, 2010  
 LOCATION: Caledon, Ontario  
 EQUIPMENT: Solid Stem Augers  
 CLIENT: Dillon Consulting Limited  
 ELEVATION DATUM: n/a  
 FILE: 1-10-5056

SOIL PROFILE		SAMPLES			PENETRATION RESISTANCE PLOT	PLASTIC LIMIT	NATURAL MOISTURE CONTENT	LIQUID LIMIT	ORGANIC VAPOUR	STANDPIPE INSTALLATION OR REMARKS
ELEV DEPTH	DESCRIPTION	STRAT PLOT	NUMBER	TYPE						
0.0	Ground Surface 180mm ASPHALT	[Solid black]								
0.2	430mm FILL - Sand and Gravel, trace silt, dense, brown, damp	[Cross-hatch]	1	SS	40					
0.6	GRAVELLY SAND some silt, trace clay, compact to dense, brown, damp to moist	[Dotted]	2	SS	17					
1.4	SILTY SAND some gravel, very dense, brown, damp to moist	[Vertical lines]	3	SS	54					
2.0	End of Borehole									



**NOTES:**  
 Borehole was dry (not stabilized) and hole open to full depth on completion.



# Terraprobe

# LOG OF BOREHOLE 32

PROJECT: Bush Street and Mississauga Road, from  
Winston Churchill Boulevard to Olde Base Line Road

LOCATION: Caledon, Ontario

CLIENT: Dillon Consulting Limited

DATE: June 08, 2010

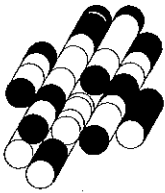
EQUIPMENT: Solid Stem Augers

ELEVATION DATUM: n/a

FILE: 1-10-5056

SOIL PROFILE		SAMPLES			PENETRATION RESISTANCE PLOT	PLASTIC LIMIT	NATURAL MOISTURE CONTENT	LIQUID LIMIT	ORGANIC VAPOUR	STANDPIPE INSTALLATION OR REMARKS
ELEV DEPTH	DESCRIPTION	STRAT PLOT	NUMBER	TYPE						
0.0	Ground Surface 140mm ASPHALT	[Solid black]								
0.1	260mm FILL - Sand and Gravel, some silt, compact, brown, moist to wet	[Cross-hatch]	1	SS	18					
0.4	FILL - Sandy Silt, trace gravel, trace organics, compact, dark brown, wet	[Cross-hatch]								
0.8	GRAVELLY SAND some silt, trace clay, trace organics, compact to dense, brown, wet	[Dotted]	2	SS	46					
			3	SS	16					
2.0	End of Borehole									

NOTES:  
Borehole was dry (not stabilized) and hole open to full depth on completion.



# Terraprobe

# LOG OF BOREHOLE 33

PROJECT: Bush Street and Mississauga Road, from  
Winston Churchill Boulevard to Olde Base Line Road

DATE: June 08, 2010

LOCATION: Caledon, Ontario

EQUIPMENT: Solid Stem Augers

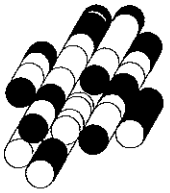
CLIENT: Dillon Consulting Limited

ELEVATION DATUM: n/a

FILE: 1-10-5056

ELEV DEPTH	SOIL PROFILE DESCRIPTION	STRAT PLOT	SAMPLES		ELEVATION SCALE	PENETRATION RESISTANCE PLOT		PLASTIC LIMIT w <sub>p</sub>	NATURAL MOISTURE CONTENT w	LIQUID LIMIT w <sub>L</sub>	ORGANIC VAPOUR (ppm)	STANDPIPE INSTALLATION OR REMARKS
			NUMBER	TYPE		"N" VALUES	SHEAR STRENGTH kPa					
0.0	Ground Surface 110mm ASPHALT											
0.1	220mm FILL - Gravelly Sand, trace silt, compact, brown, dry		1	SS	20							
0.3	SANDY GRAVEL some silt, compact to very dense, brown, wet		2	SS	55							
1.3	SILTY SAND - some gravel, very dense, brown, moist to wet		3	SS	50/ 5cm							
1.4	End of Borehole											

NOTES:  
Borehole was dry (not stabilized) and hole open to full depth on completion.



# Terraprobe

# LOG OF BOREHOLE 34

PROJECT: Bush Street and Mississauga Road, from  
Winston Churchill Boulevard to Olde Base Line Road

DATE: June 08, 2010

LOCATION: Caledon, Ontario

EQUIPMENT: Solid Stem Augers

CLIENT: Dillon Consulting Limited

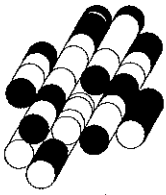
ELEVATION DATUM: n/a

FILE: 1-10-5056

ELEV DEPTH	SOIL PROFILE DESCRIPTION	STRAT PLOT	SAMPLES			ELEVATION SCALE	PENETRATION RESISTANCE PLOT		PLASTIC LIMIT w <sub>p</sub>	NATURAL MOISTURE CONTENT w	LIQUID LIMIT w <sub>L</sub>	ORGANIC VAPOUR (ppm)	STANDPIPE INSTALLATION OR REMARKS
			NUMBER	TYPE	'N' VALUES		20	40					
0.0	Ground Surface 120mm ASPHALT	[Pattern]											
0.1	280mm FILL - Gravelly Sand, trace silt, dense, brown, damp	[Pattern]	1	SS	37								
0.4	FILL - Silty Sand, trace gravel, dense, brown, wet	[Pattern]											
0.8	GRAVELLY SAND trace silt, compact, brown, moist	[Pattern]	2	SS	17								
1.4	SILTY SAND - some gravel, very dense, brown, damp	[Pattern]	3	SS	50/ 13cm								
1.5	End of Borehole												

NOTES:  
Borehole was dry (not stabilized) and hole open to full depth on completion.





# Terraprobe

# LOG OF BOREHOLE 35

PROJECT: Bush Street and Mississauga Road, from  
Winston Churchill Boulevard to Olde Base Line Road

DATE: June 08, 2010

LOCATION: Caledon, Ontario

EQUIPMENT: Solid Stem Augers

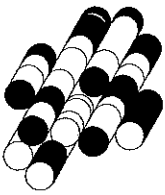
CLIENT: Dillon Consulting Limited

ELEVATION DATUM: n/a

FILE: 1-10-5056

ELEV DEPTH	SOIL PROFILE DESCRIPTION	STRAT PLOT	SAMPLES		ELEVATION SCALE	PENETRATION RESISTANCE PLOT	PLASTIC LIMIT	NATURAL MOISTURE CONTENT	LIQUID LIMIT	ORGANIC VAPOUR (ppm)	STANDPIPE INSTALLATION OR REMARKS
			NUMBER	TYPE							
0.0	Ground Surface										
0.1	100mm ASPHALT										
0.5	370mm FILL - Gravelly Sand, trace silt, compact, brown, damp		1	SS	17						
	SANDY GRAVEL trace silt, compact, brown, moist to wet		2	SS	22						
1.5	SILTY SAND - some gravel, very dense, brown, damp		3	SS	93						
1.8	End of Borehole										

NOTES:  
Borehole was dry (not stabilized) and hole open to full depth on completion.



# Terraprobe

# LOG OF BOREHOLE 36

PROJECT: Bush Street and Mississauga Road, from  
Winston Churchill Boulevard to Olde Base Line Road

DATE: June 08, 2010

LOCATION: Caledon, Ontario

EQUIPMENT: Solid Stem Augers

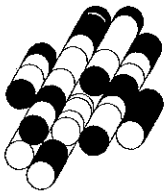
CLIENT: Dillon Consulting Limited

ELEVATION DATUM: n/a

FILE: 1-10-5056

SOIL PROFILE		SAMPLES			ELEVATION SCALE	PENETRATION RESISTANCE PLOT		PLASTIC NATURAL LIQUID LIMIT			ORGANIC VAPOUR (ppm)	STANDPIPE INSTALLATION OR REMARKS
ELEV DEPTH	DESCRIPTION	STRAT PLOT	NUMBER	TYPE		"N" VALUES	WATER CONTENT (%)	W <sub>P</sub>	W	W <sub>L</sub>		
0.0	Ground Surface 200mm ASPHALT											
0.2	330mm FILL - Sand and Gravel, trace silt, compact, brown, dry		1	SS	20							
0.5	GRAVELLY SAND some silt, compact, brown, moist		2	SS	50/ 0cm							
0.8	SILTY SAND some gravel, brown, damp		3	SS	50/ 0cm							
1.4	End of Borehole											

NOTES:  
Borehole was dry (not stabilized) and hole open to full depth on completion.



# Terraprobe

# LOG OF BOREHOLE 37

PROJECT: Bush Street and Mississauga Road, from  
Winston Churchill Boulevard to Olde Base Line Road

DATE: June 08, 2010

LOCATION: Caledon, Ontario

EQUIPMENT: Solid Stem Augers

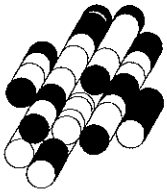
CLIENT: Dillon Consulting Limited

ELEVATION DATUM: n/a

FILE: 1-10-5056

SOIL PROFILE		SAMPLES			ELEVATION SCALE	PENETRATION RESISTANCE PLOT 20 40 60 80 100	PLASTIC LIMIT W <sub>P</sub>	NATURAL MOISTURE CONTENT W	LIQUID LIMIT W <sub>L</sub>	ORGANIC VAPOUR (ppm)	STANDPIPE INSTALLATION OR REMARKS
ELEV DEPTH	DESCRIPTION	STRAT PLOT	NUMBER	TYPE							
0.0	Ground Surface 180mm ASPHALT	[Solid black]									
0.2	220mm FILL - Sand and Gravel, trace silt, compact, brown, damp	[Cross-hatched]	1	SS	15						
0.4	FILL - Sandy Silt, trace gravel, compact, brown, wet	[Cross-hatched]									
0.8	SANDY GRAVEL some silt, very dense, brown, wet	[Dotted]	2	SS	55						
1.4	SILTY SAND - some gravel, occasional cobbles, very dense, brown, wet	[Dotted]	3	SS	50/ 2.5cm						
1.5	End of Borehole										

NOTES:  
Borehole was dry (not stabilized) and hole open to full depth on completion.



# Terraprobe

# LOG OF BOREHOLE 38

PROJECT: Bush Street and Mississauga Road, from  
 Winston Churchill Boulevard to Olde Base Line Road

LOCATION: Caledon, Ontario

CLIENT: Dillon Consulting Limited

DATE: June 11, 2010

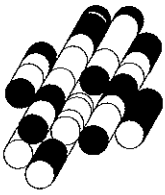
EQUIPMENT: Solid Stem Augers

ELEVATION DATUM: n/a

FILE: 1-10-5056

ELEV DEPTH	SOIL PROFILE DESCRIPTION	STRAT PLOT	SAMPLES			ELEVATION SCALE	PENETRATION RESISTANCE PLOT	PLASTIC LIMIT w <sub>p</sub>	NATURAL MOISTURE CONTENT w	LIQUID LIMIT w <sub>L</sub>	ORGANIC VAPOUR (ppm)	STANDPIPE INSTALLATION OR REMARKS
			NUMBER	TYPE	"N" VALUES							
0.0	Ground Surface 200mm ASPHALT											
0.2	500mm FILL - Sand and Gravel, trace silt, very dense, brown, moist		1	SS	50/ 8cm							
0.7	GRAVELLY SAND some silt, dense to very dense, brown, damp		2	SS	32							
1.5	End of Borehole		3	SS	50/ 15cm							

**NOTES:**  
 Borehole was dry (not stabilized) and hole open to full depth on completion.



# Terraprobe

# LOG OF BOREHOLE 39

PROJECT: Bush Street and Mississauga Road, from  
Winston Churchill Boulevard to Olde Base Line Road

DATE: June 11, 2010

LOCATION: Caledon, Ontario

EQUIPMENT: Solid Stem Augers

CLIENT: Dillon Consulting Limited

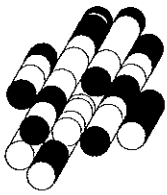
ELEVATION DATUM: n/a

FILE: 1-10-5056

SOIL PROFILE			SAMPLES			ELEVATION SCALE	PENETRATION RESISTANCE PLOT 20 40 60 80 100	PLASTIC LIMIT NATURAL MOISTURE CONTENT LIQUID LIMIT	ORGANIC VAPOUR (ppm)	STANDPIPE INSTALLATION OR REMARKS
ELEV DEPTH	DESCRIPTION	STRAT PLOT	NUMBER	TYPE	"N" VALUES					
0.0	Ground Surface 150mm ASPHALT									
0.2	460mm FILL - Sand and Gravel, trace silt, dense, brown, damp		1	SS	36					
0.6	GRAVELLY SAND occasional cobbles, dense to very dense, brown, damp		2	SS	48					
			3	SS	86/ 28cm					
1.8	End of Borehole									

**NOTES:**

Borehole was dry (not stabilized) and hole open to full depth on completion.



# Terraprobe

# LOG OF BOREHOLE 40

PROJECT: Bush Street and Mississauga Road, from  
Winston Churchill Boulevard to Olde Base Line Road

LOCATION: Caledon, Ontario

CLIENT: Dillon Consulting Limited

DATE: June 11, 2010

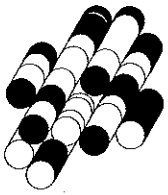
EQUIPMENT: Solid Stem Augers

ELEVATION DATUM: n/a

FILE: 1-10-5056

SOIL PROFILE		STRAT PLOT	SAMPLES		ELEVATION SCALE	PENETRATION RESISTANCE PLOT 20 40 60 80 100	PLASTIC LIMIT NATURAL MOISTURE CONTENT LIQUID LIMIT	ORGANIC VAPOUR (ppm)	STANDPIPE INSTALLATION OR REMARKS
ELEV DEPTH	DESCRIPTION		NUMBER	TYPE					
0.0	Ground Surface 180mm ASPHALT	[Solid black]							
0.2	150mm FILL - Sand and Gravel, some silt, compact, brown, damp	[Cross-hatch]	1	SS	12				
0.3	FILL - Silty Clay, some sand, trace gravel, occasional cobbles, stiff to hard, brown, damp to moist	[Cross-hatch]	2	SS	50/ 5cm				
2.0	End of Borehole	[Cross-hatch]	3	SS	12	GR SA, SI, CL 6 17 49 28			

**NOTES:**  
Borehole was dry (not stabilized) and hole open to full depth on completion.



# Terraprobe

# LOG OF BOREHOLE 41

PROJECT: Bush Street and Mississauga Road, from  
Winston Churchill Boulevard to Olde Base Line Road

LOCATION: Caledon, Ontario

CLIENT: Dillon Consulting Limited

DATE: June 11, 2010

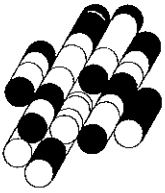
EQUIPMENT: Solid Stem Augers

ELEVATION DATUM: n/a

FILE: 1-10-5056

ELEV DEPTH	SOIL PROFILE DESCRIPTION	STRAT PLOT	SAMPLES			ELEVATION SCALE	PENETRATION RESISTANCE PLOT					PLASTIC LIMIT w <sub>p</sub>	NATURAL MOISTURE CONTENT w	LIQUID LIMIT w <sub>L</sub>	ORGANIC VAPOUR (ppm)	STANDPIPE INSTALLATION OR REMARKS
			NUMBER	TYPE	"N" VALUES		SHEAR STRENGTH kPa									
							20	40	60	80	100					
0.0	Ground Surface 165mm ASPHALT															
0.2	280mm FILL - Sand and Gravel, some silt, compact, brown, damp		1	SS	21		36	48	16							
0.4	FILL - Sandy Silt, trace clay, trace gravel, compact, brown, wet															
0.8	SANDY GRAVEL trace silt, compact, brown, moist		2	SS	21											
			3	SS	25											
2.0	End of Borehole															

NOTES:  
Borehole was dry (not stabilized) and hole open to full depth on completion.



# Terraprobe

# LOG OF BOREHOLE 42

PROJECT: Bush Street and Mississauga Road, from  
Winston Churchill Boulevard to Oide Base Line Road

DATE: June 11, 2010

LOCATION: Caledon, Ontario

EQUIPMENT: Solid Stem Augers

CLIENT: Dillon Consulting Limited

ELEVATION DATUM: n/a

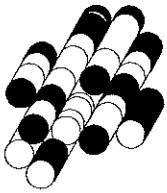
FILE: 1-10-5056

SOIL PROFILE		SAMPLES			PENETRATION RESISTANCE PLOT	PLASTIC LIMIT	NATURAL MOISTURE CONTENT	LIQUID LIMIT	ORGANIC VAPOUR (ppm)	STANDPIPE INSTALLATION OR REMARKS
ELEV DEPTH	DESCRIPTION	STRAT PLOT	NUMBER	TYPE						
0.0	Ground Surface									
0.1	100mm ASPHALT									
	460mm FILL - Sand and Gravel, trace silt, dense, brown, wet		1	SS	43		○			
0.6	SANDY GRAVEL trace silt, compact to very dense, brown, damp to moist		2	SS	26		○			
			3	SS	87/28cm		○			
1.8	End of Borehole									

**NOTES:**

Borehole was dry (not stabilized) and hole open to full depth on completion.





# Terraprobe

# LOG OF BOREHOLE 43

PROJECT: Bush Street and Mississauga Road, from  
Winston Churchill Boulevard to Olde Base Line Road

DATE: June 11, 2010

LOCATION: Caledon, Ontario

EQUIPMENT: Solid Stem Augers

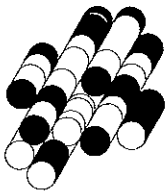
CLIENT: Dillon Consulting Limited

ELEVATION DATUM: n/a

FILE: 1-10-5056

SOIL PROFILE		SAMPLES			ELEVATION SCALE	PENETRATION RESISTANCE PLOT 20 40 60 80 100	PLASTIC LIMIT NATURAL MOISTURE CONTENT LIQUID LIMIT	ORGANIC VAPOUR (ppm)	STANDPIPE INSTALLATION OR REMARKS
ELEV DEPTH	DESCRIPTION	STRAT PLOT	NUMBER	TYPE					
0.0	Ground Surface 170mm ASPHALT	[Solid black]							
0.2	190mm FILL - Sand and Gravel, trace silt, dense, brown, damp	[Cross-hatched]	1	SS	39				
0.4	FILL - Sandy Silt, trace gravel, dense, brown, wet	[Dotted]							
0.8	SANDY GRAVEL trace silt, compact to very dense, brown, damp	[Dotted with small circles]	2	SS	22				
			3	SS	50/ 10cm				
1.6	End of Borehole								

NOTES:  
Borehole was dry (not stabilized) and hole open to full depth on completion.



# Terraprobe

# LOG OF BOREHOLE 44

PROJECT: Bush Street and Mississauga Road, from  
Winston Churchill Boulevard to Olde Base Line Road

DATE: June 11, 2010

LOCATION: Caledon, Ontario

EQUIPMENT: Solid Stem Augers

CLIENT: Dillon Consulting Limited

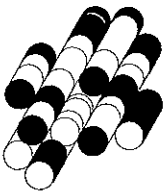
ELEVATION DATUM: n/a

FILE: 1-10-5056

SOIL PROFILE		STRAT PLOT	SAMPLES		ELEVATION SCALE	PENETRATION RESISTANCE PLOT	PLASTIC LIMIT NATURAL MOISTURE CONTENT LIQUID LIMIT	ORGANIC VAPOUR (ppm)	STANDPIPE INSTALLATION OR REMARKS
ELEV DEPTH	DESCRIPTION		NUMBER	TYPE					
0.0	Ground Surface 220mm ASPHALT								
0.2	250mm FILL - Sand and Gravel, some silt, compact, brown, wet		1	SS	13				
0.5	SANDY GRAVEL some silt, trace clay, compact to very dense, brown, damp		2	SS	68	GR, SA, SI, CL 52, 29, 16, 3			
			3	SS	63				
2.0	End of Borehole								

**NOTES:**

Borehole was dry (not stabilized) and hole open to full depth on completion.



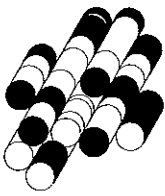
# Terraprobe

# LOG OF BOREHOLE 45

PROJECT: Bush Street and Mississauga Road, from Winston Churchill Boulevard to Olde Base Line Road  
 DATE: June 11, 2010  
 LOCATION: Caledon, Ontario  
 EQUIPMENT: Solid Stem Augers  
 CLIENT: Dillon Consulting Limited  
 ELEVATION DATUM: n/a  
 FILE: 1-10-5056

SOIL PROFILE		SAMPLES			ELEVATION SCALE	PENETRATION RESISTANCE PLOT 20 40 60 80 100	PLASTIC LIMIT NATURAL MOISTURE CONTENT LIQUID LIMIT w <sub>p</sub> — w — w <sub>L</sub>	ORGANIC VAPOUR (ppm)	STANDPIPE INSTALLATION OR REMARKS
ELEV DEPTH	DESCRIPTION	STRAT PLOT	NUMBER	TYPE					
0.0	Ground Surface 370mm ASPHALT								
0.4	150mm FILL - Sand and Gravel, trace silt, compact, brown, damp		1	SS	19				
0.5	FILL - Sandy Silt, trace gravel, compact, brown, wet		2	SS	50/15cm				
0.8	SILTY SAND some gravel, occasional cobbles, very dense, brown, damp to moist		3	SS	50/15cm				
1.7	End of Borehole								

**NOTES:**  
 Borehole was dry (not stabilized) and hole open to full depth on completion.



# Terraprobe

# LOG OF BOREHOLE 46

PROJECT: Bush Street and Mississauga Road, from  
Winston Churchill Boulevard to Olde Base Line Road

DATE: June 11, 2010

LOCATION: Caledon, Ontario

EQUIPMENT: Solid Stem Augers

CLIENT: Dillon Consulting Limited

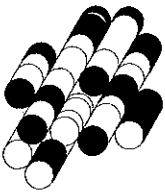
ELEVATION DATUM: n/a

FILE: 1-10-5056

SOIL PROFILE		SAMPLES			ELEVATION SCALE	PENETRATION RESISTANCE PLOT	PLASTIC LIMIT W <sub>p</sub>	NATURAL MOISTURE CONTENT w	LIQUID LIMIT W <sub>L</sub>	ORGANIC VAPOUR (ppm)	STANDPIPE INSTALLATION OR REMARKS
ELEV DEPTH	DESCRIPTION	STRAT PLOT	NUMBER	TYPE							
						20 40 60 80 100					
						20 40 60 80 100					
0.0	Ground Surface 280mm ASPHALT										
0.3	280mm FILL - Sand and Gravel, some silt, dense, brown, wet		1	SS	36						
0.6	FILL - Sandy Silt, some clay, some gravel, occasional cobbles, loose to very dense, brown, wet		2	SS	6						
			3	SS	54/ 18cm						
1.7	End of Borehole										

**NOTES:**

Borehole was dry (not stabilized) and hole open to full depth on completion.



# Terraprobe

# LOG OF BOREHOLE 47

PROJECT: Bush Street and Mississauga Road, from  
Winston Churchill Boulevard to Olde Base Line Road

DATE: June 11, 2010

LOCATION: Caledon, Ontario

EQUIPMENT: Solid Stem Augers

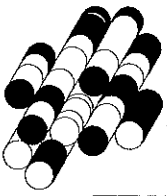
CLIENT: Dillon Consulting Limited

ELEVATION DATUM: n/a

FILE: 1-10-5056

SOIL PROFILE		SAMPLES			ELEVATION SCALE	PENETRATION RESISTANCE PLOT	PLASTIC LIMIT W <sub>P</sub>	NATURAL MOISTURE CONTENT W	LIQUID LIMIT W <sub>L</sub>	ORGANIC VAPOUR (ppm)	STANDPIPE INSTALLATION OR REMARKS
ELEV DEPTH	DESCRIPTION	STRAT PLOT	NUMBER	TYPE							
0.0	Ground Surface 260mm ASPHALT										
0.3	330mm FILL - Sand and Gravel, trace silt, very dense, brown, wet		1	SS	50/ 15cm						
0.6	FILL - Sandy Silt, gravelly, some clay, compact, brown, wet		2	SS	14	GR, SA, SI, CL 21, 31, 38, 10					
1.4	SILTY SAND gravelly, trace clay, occasional cobbles, very dense, brown, damp		3	SS	54	GR, SA, SI, CL 22, 49, 25, 4					
2.0	End of Borehole										

NOTES:  
Borehole was dry (not stabilized) and hole open to full depth on completion.



# Terraprobe

# LOG OF BOREHOLE 48

PROJECT: Bush Street and Mississauga Road, from  
Winston Churchill Boulevard to Olde Base Line Road

DATE: June 11, 2010

LOCATION: Caledon, Ontario

EQUIPMENT: Solid Stem Augers

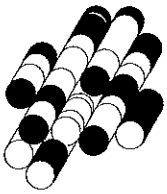
CLIENT: Dillon Consulting Limited

ELEVATION DATUM: n/a

FILE: 1-10-5056

SOIL PROFILE			SAMPLES			PENETRATION RESISTANCE PLOT	PLASTIC LIMIT	NATURAL MOISTURE CONTENT	LIQUID LIMIT	ORGANIC VAPOUR	STANDPIPE INSTALLATION OR REMARKS
ELEV DEPTH	DESCRIPTION	STRAT PLOT	NUMBER	TYPE	"N" VALUES						
0.0	Ground Surface 160mm ASPHALT										
0.2	240mm FILL - Sand and Gravel, trace silt, compact, brown, damp		1	SS	26						
0.4	SILTY SAND some gravel, compact to very dense, brown, damp		2	SS	84/ 28cm						
			3	SS	74						
2.0	End of Borehole										

NOTES:  
Borehole was dry (not stabilized) and hole open to full depth on completion.



# Terraprobe

# LOG OF BOREHOLE 49

PROJECT: Bush Street and Mississauga Road, from  
Winston Churchill Boulevard to Olde Base Line Road

DATE: June 11, 2010

LOCATION: Caledon, Ontario

EQUIPMENT: Solid Stem Augers

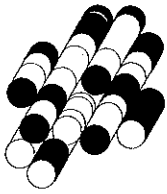
CLIENT: Dillon Consulting Limited

ELEVATION DATUM: n/a

FILE: 1-10-5056

SOIL PROFILE			SAMPLES			ELEVATION SCALE	PENETRATION RESISTANCE PLOT 20 40 60 80 100	PLASTIC LIMIT w <sub>p</sub>	NATURAL MOISTURE CONTENT w	LIQUID LIMIT w <sub>L</sub>	ORGANIC VAPOUR (ppm)	STANDPIPE INSTALLATION OR REMARKS
ELEV. DEPTH	DESCRIPTION	STRAT. PLOT	NUMBER	TYPE	"N" VALUES							
0.0	Ground Surface											
0.1	75mm ASPHALT	[Hatched Pattern]	1	SS	50/15cm							
	525mm FILL - Gravelly Sand, trace silt, very dense, brown, damp	[Cross-hatched Pattern]										
0.6	SILTY SAND some gravel, dense, brown, moist to wet	[Dotted Pattern]	2	SS	48							
			3	SS	40							
2.0	End of Borehole											

NOTES:  
Borehole was dry (not stabilized) and hole open to full depth on completion.



# Terraprobe

# LOG OF BOREHOLE 50

PROJECT: Bush Street and Mississauga Road, from  
Winston Churchill Boulevard to Oide Base Line Road

DATE: June 11, 2010

LOCATION: Caledon, Ontario

EQUIPMENT: Solid Stem Augers

CLIENT: Dillon Consulting Limited

ELEVATION DATUM: n/a

FILE: 1-10-5056

SOIL PROFILE		SAMPLES			ELEVATION SCALE	PENETRATION RESISTANCE PLOT					PLASTIC LIMIT w <sub>p</sub>	NATURAL MOISTURE CONTENT w	LIQUID LIMIT w <sub>L</sub>	ORGANIC VAPOUR (ppm)	STANDPIPE INSTALLATION OR REMARKS
ELEV. DEPTH	DESCRIPTION	STRAT PLOT	NUMBER	TYPE		"N" VALUES	SHEAR STRENGTH kPa								
						20	40	60	80	100					
0.0	Ground Surface 150mm ASPHALT														
0.2	490mm FILL - Gravelly Sand, trace silt, very dense, brown, damp		1	SS	50/ 15cm										
0.6	SILTY SAND gravelly, very dense, brown, damp		2	SS	50/ 15cm										
			3	SS	82/ 28cm										
1.8	End of Borehole														

**NOTES:**

Borehole was dry (not stabilized) and hole open to full depth on completion.



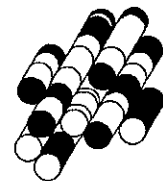
### Granular Thickness at Select Shoulder Locations

Borehole	Approx. Station	Location	Granular Thickness (mm)
1S	36+950	Mississauga Road	700
2S	37+115	Mississauga Road	680
5S	37+610	Mississauga Road	450
6S	37+775	Mississauga Road	600
8S	38+105	Mississauga Road	320
9S	38+270	Mississauga Road	320
12S	38+765	Mississauga Road	530
13S	38+930	Mississauga Road	600
17S	39+590	Mississauga Road	520
20S	40+085	Mississauga Road	470
24S	40+745	Mississauga Road	740
25S	40+910	Mississauga Road	420
28S	41+400	Mississauga Road	420
29S	41+570	Mississauga Road	430
33S	42+230	Mississauga Road	440
37S	42+890	Mississauga Road	410
39S	1+855	Bush Street	620
42S	1+375	Bush Street	590
43S	1+195	Bush Street	390
46S	0+700	Bush Street	490
47S	0+535	Bush Street	590
50S	-0+040	Bush Street	700

# **APPENDIX B**

## **Pavement Condition Evaluation Forms**

**Terraprobe Inc.**



# Flexible Pavement Condition Evaluation Form

Ministry of Transportation



Location: Mississauga Road, Caledon, Ontario District  Highway

From: Sta. 36+900 To Sta. 40+000

LHRS  begins  km Section Length  m Traffic Direction

Survey Date  year  month  PCR  RCR

Contract No.  -  WP No.

B B - both directions; N - northbound; S - southbound;  
E - eastbound; W - westbound

A A - all lanes; C - collector; E - express;  
O - others (additional lanes)

A F - freeway; A - arterial; C - collector; L - local;  
S - secondary

Shoulders	Severity of Distress			Density of Occurrence, %		
	Dominant Type	Right	Left	Right	Left	
Distress		Mod. Sev.	Mod. Sev.	10-30	10-30	>30
Paved Full	Cracking	2	1	2	1	2
Paved Partial	Pavement Edge/ Curb Separation					
Surface Treated	Distortion					
Primed	Breakup/Separation					
Gravel	Edge Break					
	Breakup/Separation					

Maintenance Treatment	EXTENT OF OCCURRENCE, %				
	<10	10-20	20-50	50-80	>80
Pavement					
Manual Patching	1	2	3	4	5
Machine Patching	✓				
Spray Patching	✓				
Shoulders					
Rout and Seal Cracks					
Chip Seal					
Manual Patching					
Machine Patching					
Rout and Seal Cracks					
Chip Seal					

Other Comments: (e.g., subsections, additional contracts) Partially paved shoulders exist at some locations

Ride Condition Rating (at 80 km/hr)	Description	Severity of Distress				Density of Distress Extent of Occurrence %							
		Very Slight	Slight	Moderate	Severe	Very Severe	Few	Intermittent	Frequent	Extensive	Throughout		
PAVEMENT	1 Ravelling & C. Agg. Loss												
	2 Flushing												
	3 Rippling and Shoving												
	4 Wheel Track Rutting												
	5 Distortion												
Longitudinal Wheel Track	6 Single and Multiple												
	7 Alligator												
Centre Line	8 Single and Multiple												
	9 Alligator												
Pavement Edge	10 Single and Multiple												
	11 Alligator												
Transverse	12 Half, Full and Multiple												
	13 Alligator												
Longitudinal Meander and Midlane	14 Random / Map												
	15 Random / Map												

Distress Comments: (items not covered above)

Pot holes at Sta. 38+100 and Sta. 41+775

Ditches generally do not conform to OPSD 200.010

Ponding on shoulder, lack of maintenance and vegetated shoulders observed within project limits

Evaluated by: Dash Brahmhatt, P. Eng



# Flexible Pavement Condition Evaluation Form

Location: Bush Street, Caledon, Ontario District 

--	--	--	--

From: Sta. -0+044 To: Sta. 2+070

LHRS 

--	--	--	--	--	--	--	--	--	--	--

 km 

--	--	--	--	--

 Section Length 

2	1	1	1	4
---	---	---	---	---

 m

Survey Date 

1	0
---	---

 month 

0	5
---	---

 year 

--	--

 begins 

--	--	--	--

 offset 

--	--	--	--

 PCR 

7	5
---	---

 RCR 

7	5
---	---

Contract No. 

--	--	--	--	--	--	--	--	--	--	--

 WP No. 

--	--	--	--	--	--	--	--	--	--	--

Traffic Direction 

B
---

 Facility 

A
---

 Class 

A
---

District 

--	--	--	--

 Highway 

--	--	--	--

B - both directions; N - northbound; S - southbound;  
 E - eastbound; W - westbound  
 A - all lanes; C - collector; E - express;  
 O - others (additional lanes)  
 F - freeway; A - arterial; C - collector; L - local;  
 S - secondary

Ride Condition Rating (at 80 km/hr)	Severity of Distress					Density of Distress Extent of Occurrence %				
	Very Slight	Slight	Moderate	Severe	Very Severe	Few	Intermittent	Frequent	Extensive	Throughout
10	1	2	3	4	5	<10	10-20	20-50	50-80	80-100
8										
6										
4										
2										
0										

Surface Defects	PAVEMENT														
	1	2	3	4	5	1	2	3	4	5	1	2	3	4	5
1															
2															
3															
4															
5															
6															
7															
8															
9															
10															
11															
12															
13															
14															
15															

Shoulders	Dominant Type	Distress	Severity of Distress						Density of Distress Extent of Occurrence, %							
			Right			Left			Right			Left				
			Mod.	Sev.	1	2	1	2	10-30	>30	>30	>30	10-30	>30	>30	
	Paved Full	Cracking	1	2	1	2	1	2	1	2	1	2	1	2	1	2
	Paved Partial	Pavement Edge/Curb Separation														
	Surface Treated	Distortion														
	Primed	Breakup/Separation														
	Gravel	Edge Break														
		Breakup/Separation														

Maintenance Treatment	EXTENT OF OCCURRENCE, %									
	<10		10-20		20-50		50-80		>80	
	1	2	3	4	5	6	7	8	9	
Pavement										
Manual Patching										
Machine Patching										
Spray Patching										
Rout and Seal Cracks										
Chip Seal										
Shoulders										
Manual Patching										
Machine Patching										
Rout and Seal Cracks										
Chip Seal										

Distress Comments: (items not covered above)

Pot holes at Sta. 0+375 and Sta. 0+520  
 Ditches generally do not conform to OPSD 200.010

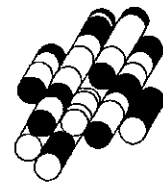
Other Comments: (e.g., subsections, additional contracts) Partially paved shoulders exist at some locations

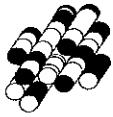
Evaluated by: Dash Brahmhatt, P. Eng

# **APPENDIX C**

## **Pavement Core Data and Photographs**

**Terraprobe Inc.**





**Terraprobe**

**Core Photographs**

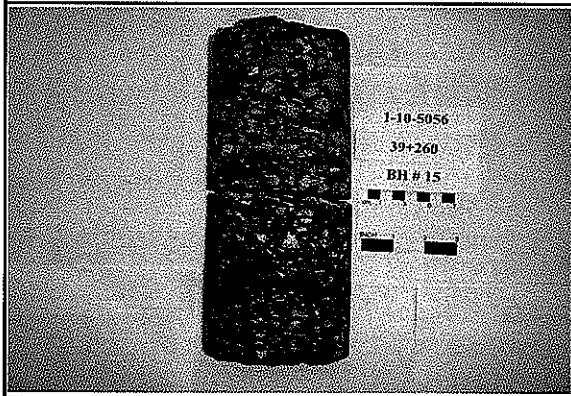
**Bush Street and Mississauga Road**

**1-10-5056**



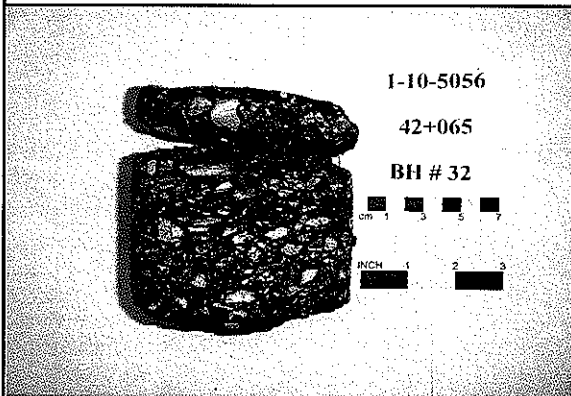
BH # 2

Type	Core (mm)
HL-3	90
HL-8	90
<b>Total</b>	<b>180</b>



BH # 15

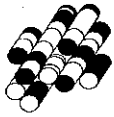
Type	Core (mm)
HL-3	250
HL-8	0
<b>Total</b>	<b>250</b>



BH # 32

Type	Core (mm)
HL-3	110
HL-8	0
<b>Total</b>	<b>110</b>

30 mm of core lost during coring operation

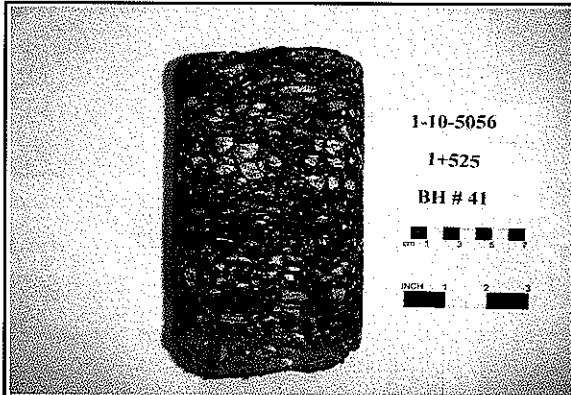


**Terraprobe**

**Core Photographs**

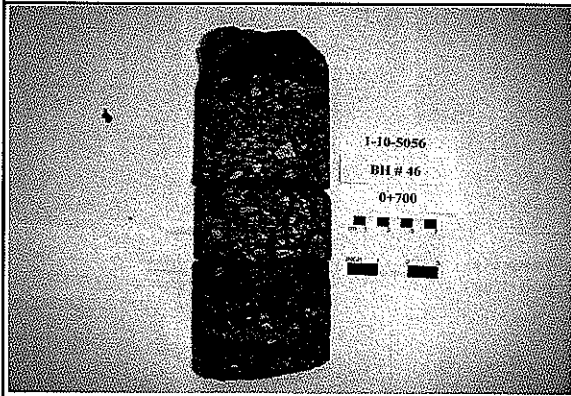
**Bush Street and Mississauga Road**

**1-10-5056**



BH # 41

Type	Core (mm)
HL-3	165
HL-8	0
Total	165



BH # 46

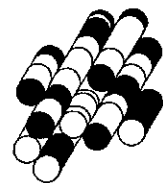
Type	Core (mm)
HL-3	280
HL-8	0
Total	280



# **APPENDIX D**

## **Laboratory Test Results**

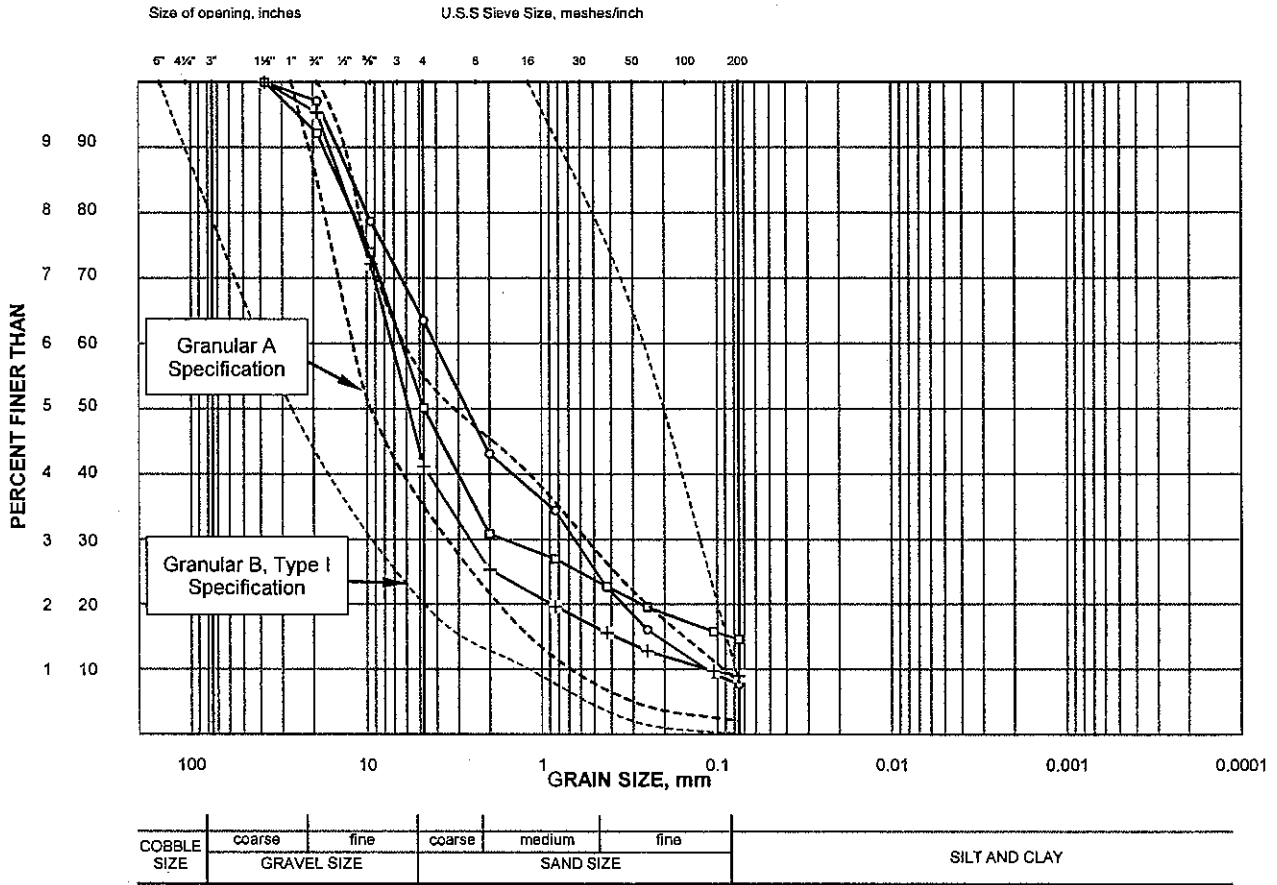
**Terraprobe Inc.**



# GRAIN SIZE DISTRIBUTION

FIGURE D1

## GRANULAR BASE/SUBBASE MATERIAL



### LEGEND

SYMBOL	ROAD	BOREHOLE NO.	STATION	SAMPLE TYPE	DEPTH (m)
o	Mississauga Road	2	37+115	Bag	0.2 - 0.6
+	Mississauga Road	15	39+260	Bag	0.3 - 0.6
□	Mississauga Road	32	42+065	Bag	0.1 - 0.4

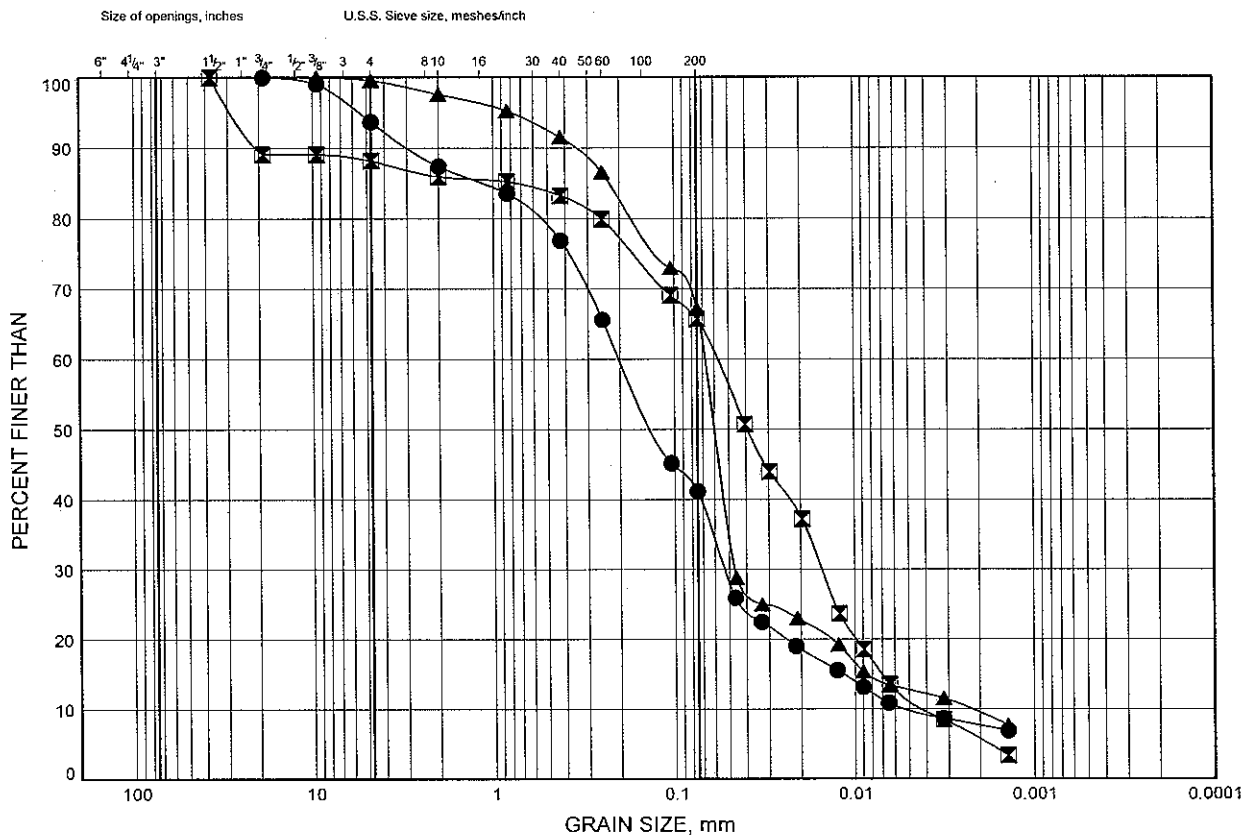
Date: July 2010  
 Project: 1-10-5056

Chkd: HA

# GRAIN SIZE DISTRIBUTION

FIGURE D2

## FILL - Silty Sand to Sandy Silt



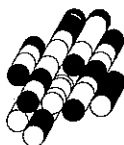
SYMBOL   BOREHOLE   DEPTH (m)   ELEVATION (m)

●                      10                      1.1  
 ✕                      21                      1.1  
 ▲                      28                      1.1

GSD 1-10-5056 PAVEMENT BH.GPJ 07/26/10

Date July 2010

Project 1-10-5056



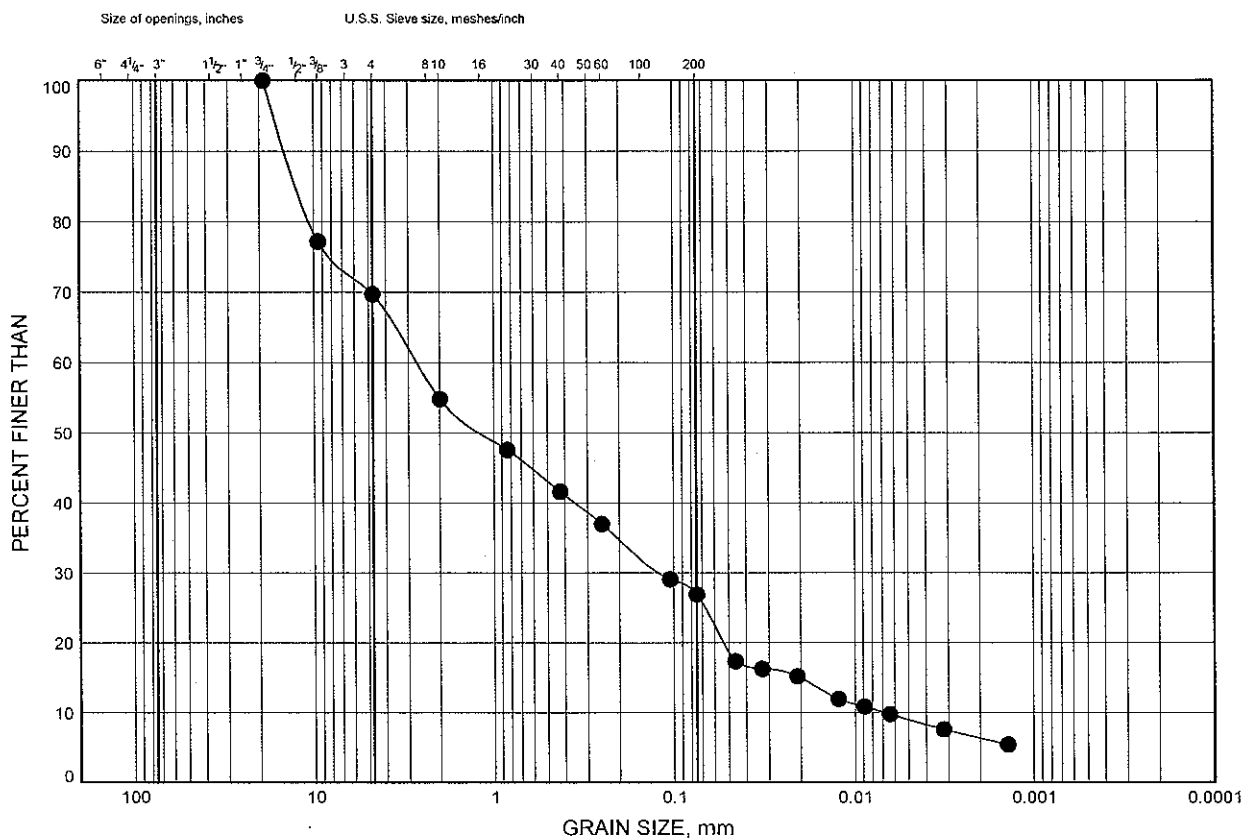
Prep'd DB

Chkd. HA

# GRAIN SIZE DISTRIBUTION

FIGURE D3

## GRAVELLY SAND



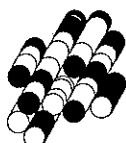
COBBLE SIZE	COARSE	FINE	COARSE	MEDIUM	FINE	SILT and CLAY
	GRAVEL		SAND			

SYMBOL	BOREHOLE	DEPTH (m)	ELEVATION (m)
●	31	1.1	

GSD 1-10-5056 PAVEMENT BH.GPJ 07/26/10

Date July 2010

Project 1-10-5056



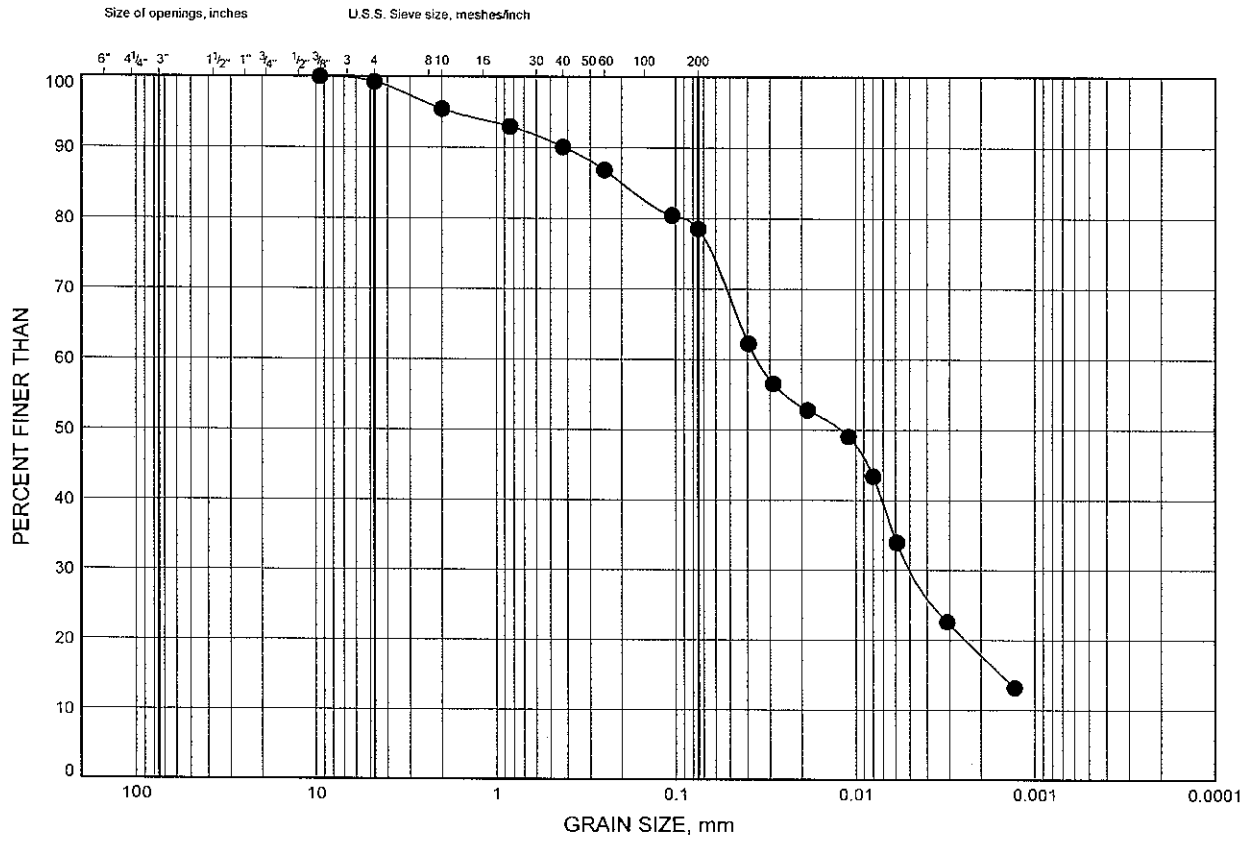
Prep'd DB

Chkd. HA

# GRAIN SIZE DISTRIBUTION

FIGURE D4

## SILTY CLAY



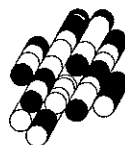
COBBLE SIZE	COARSE	FINE	COARSE	MEDIUM	FINE	SILT and CLAY
	GRAVEL		SAND			FINE GRAINED

SYMBOL	BOREHOLE	DEPTH (m)	ELEVATION (m)
●	13	1.1	

CSD 1-10-5056 PAVEMENT BH.GPJ 07/26/10

Date July 2010

Project 1-10-5056



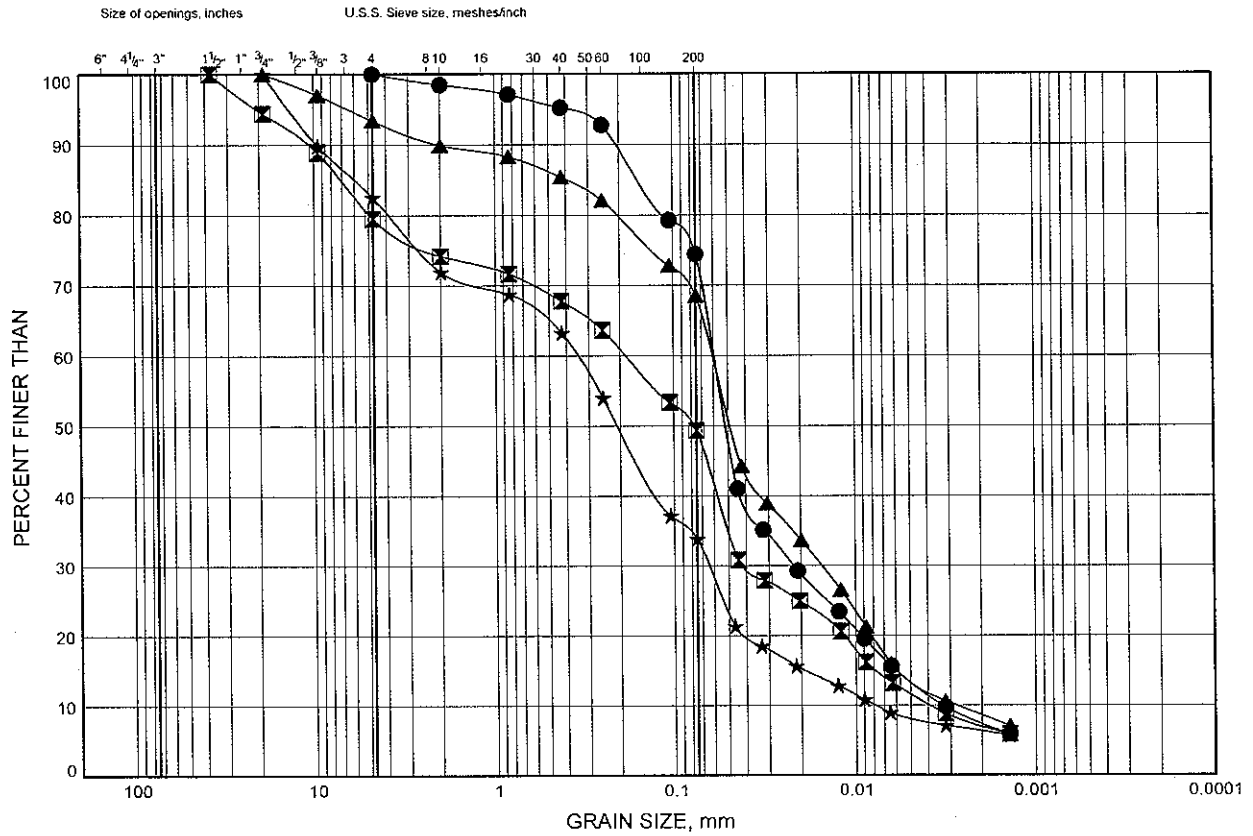
Prep'd DB

Chkd. HA

# GRAIN SIZE DISTRIBUTION

FIGURE D5

## SILTY SAND TO SANDY SILT



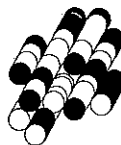
COBBLE SIZE	COARSE	FINE	COARSE	MEDIUM	FINE	SILT and CLAY
	GRAVEL		SAND			FINE GRAINED

SYMBOL    BOREHOLE    DEPTH (m)    ELEVATION (m)

●	5	1.1
◻	10	1.7
▲	11	1.1
★	7A	1.1

GSD 1-10-5056 PAVEMENT BH.GPJ 07/25/10

Date July 2010  
Project 1-10-5056

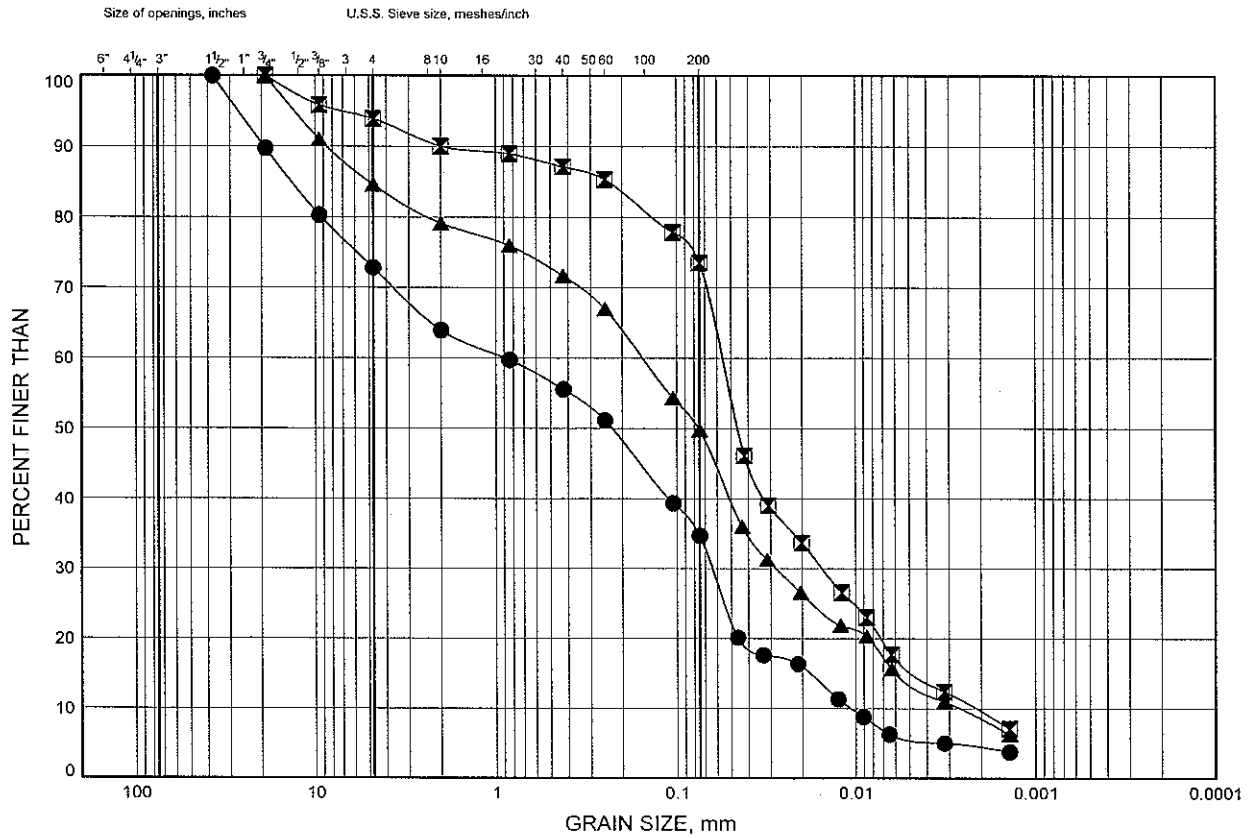


Prep'd DB  
Chkd. HA

# GRAIN SIZE DISTRIBUTION

FIGURE D6

## SILTY SAND TO SANDY SILT



COBBLE SIZE	COARSE	FINE	COARSE	MEDIUM	FINE	SILT and CLAY
	GRAVEL		SAND			FINE GRAINED

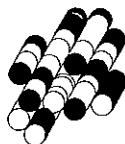
SYMBOL    BOREHOLE    DEPTH (m)    ELEVATION (m)

●	16	1.1	
⊠	18	1.1	
▲	27	1.1	

GSD 1-10-5056 PAVEMENT BH.GPJ 07/26/10

Date July 2010

Project 1-10-5056



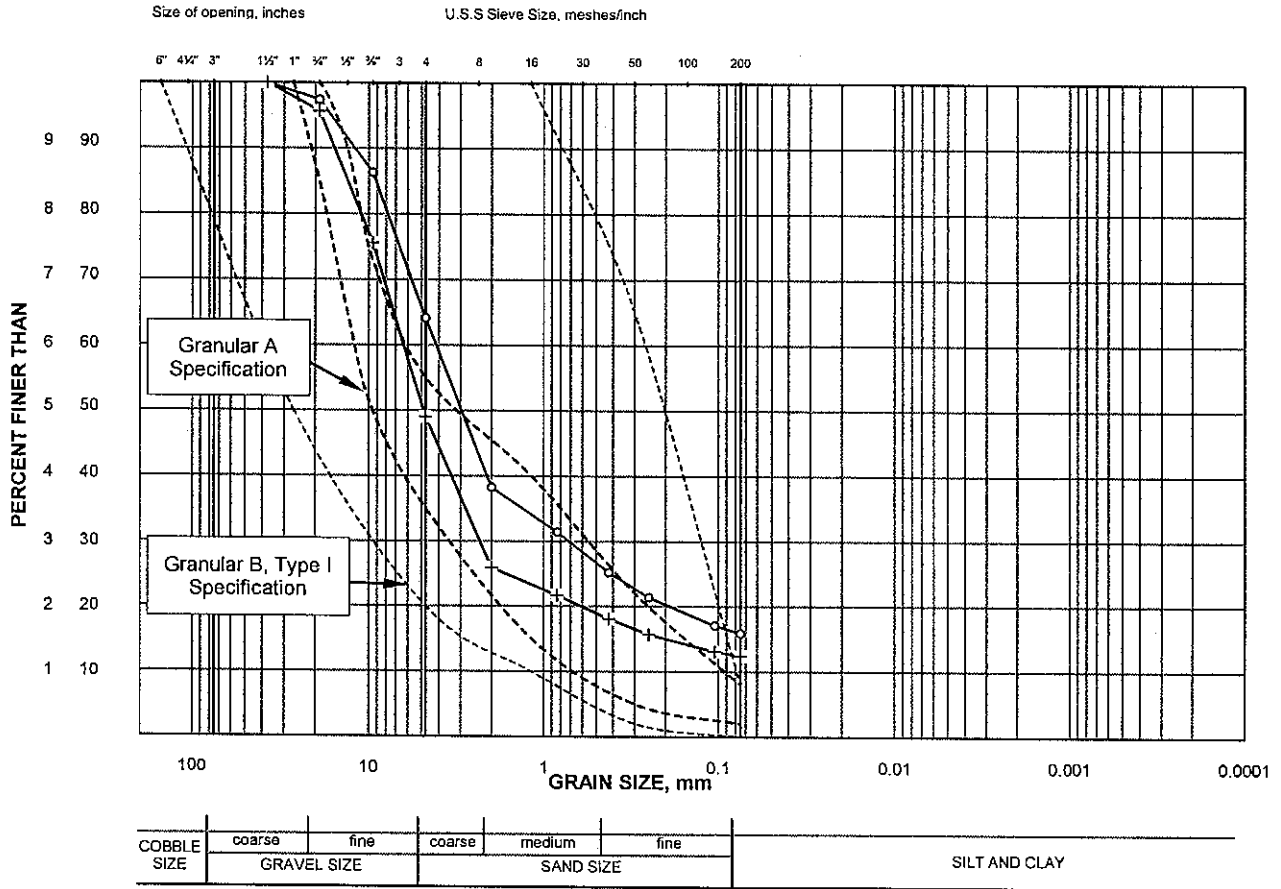
Prep'd DB

Chkd. HA

# GRAIN SIZE DISTRIBUTION

FIGURE D7

## GRANULAR BASE/SUBBASE MATERIAL



LEGEND					
SYMBOL	ROAD	BOREHOLE NO.	STATION	SAMPLE TYPE	DEPTH (m)
o	Bush Street	41	1+525	Bag	0.2 - 0.4
+	Bush Street	46	0+700	Bag	0.3 - 0.5

Date: July 2010  
 Project: 1-10-5056

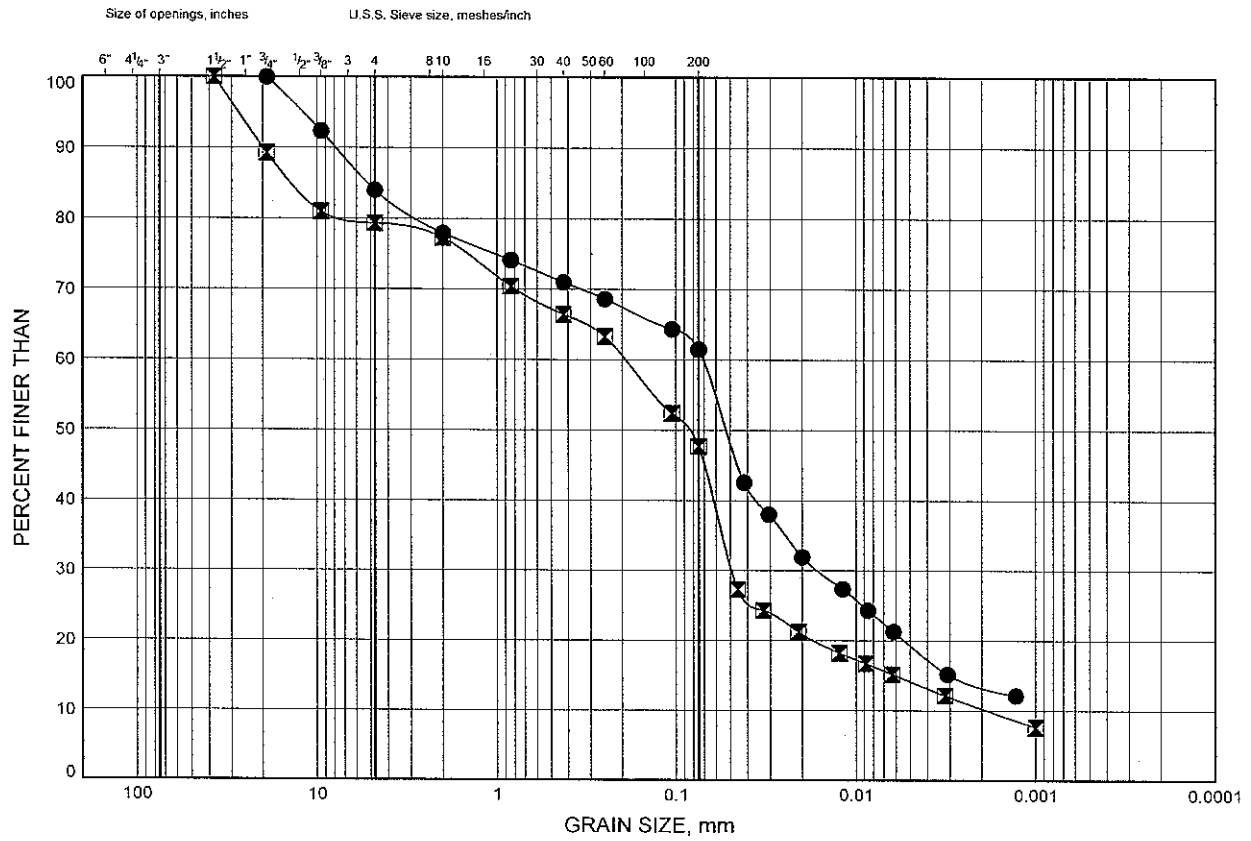
Chkd: HA



# GRAIN SIZE DISTRIBUTION

FIGURE D8

## FILL - Sandy Silt



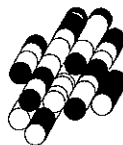
COBBLE SIZE	COARSE	FINE	COARSE	MEDIUM	FINE	SILT and CLAY
	GRAVEL		SAND			FINE GRAINED

SYMBOL	BOREHOLE	DEPTH (m)	ELEVATION (m)
●	46	1.1	
⊠	47	1.1	

GSD 1-10-5056 PAVEMENT BH.GPJ 07/28/10

Date July 2010

Project 1-10-5056



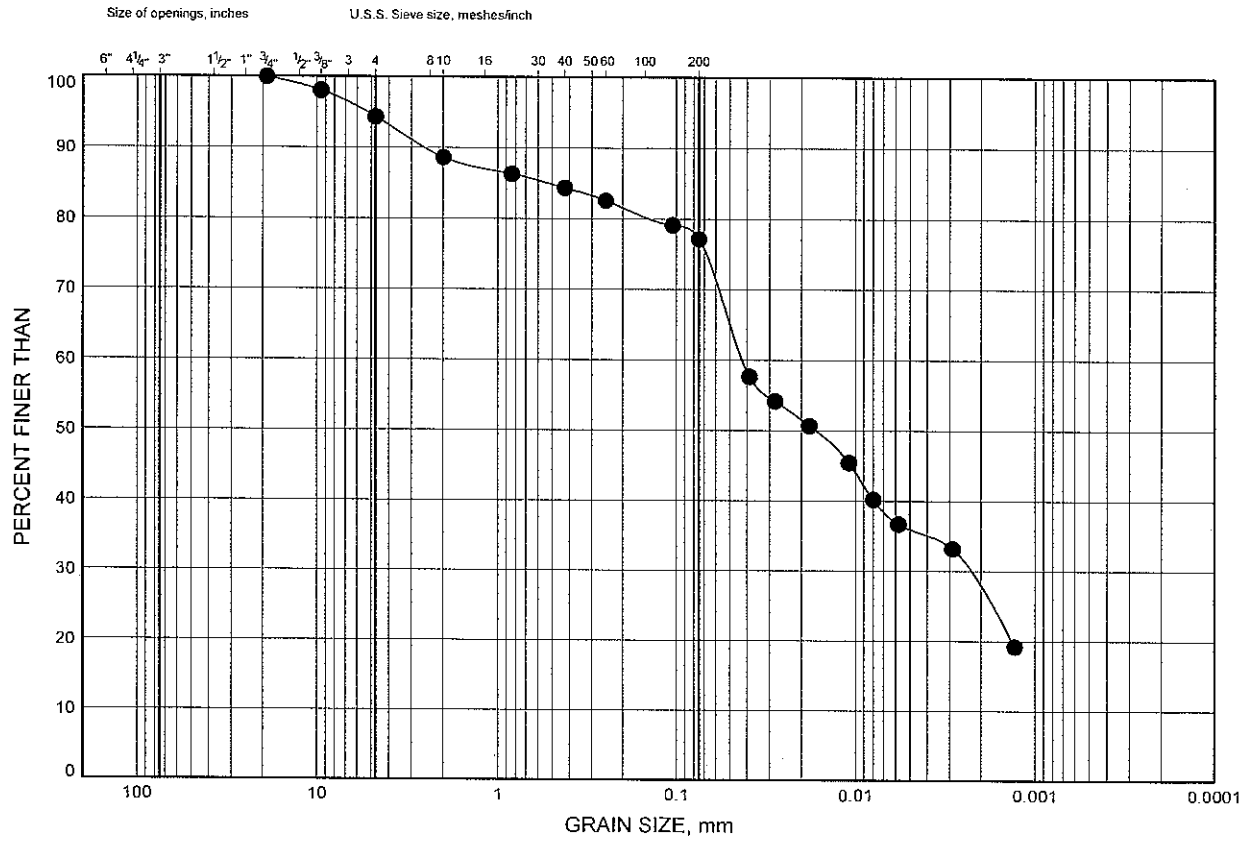
Prep'd DB

Chkd. HA

# GRAIN SIZE DISTRIBUTION

FIGURE D9

## FILL - Silty Clay



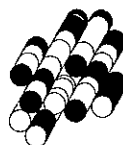
COBBLE SIZE	COARSE	FINE	COARSE	MEDIUM	FINE	SILT and CLAY FINE GRAINED
	GRAVEL		SAND			

SYMBOL	BOREHOLE	DEPTH (m)	ELEVATION (m)
●	40	1.7	

GSD 1-10-5056 PAVEMENT BH.GPJ 07/26/10

Date July 2010

Project 1-10-5056



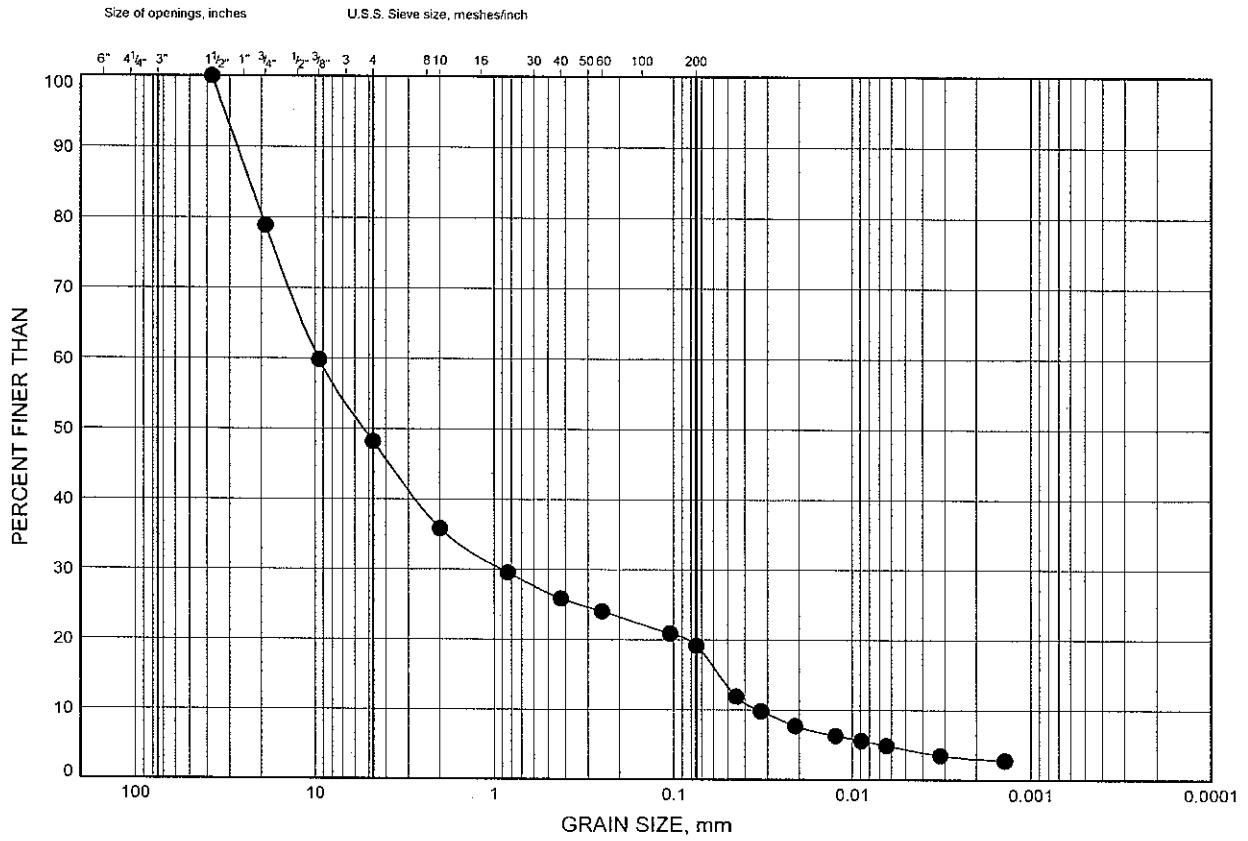
Prep'd DB

Chkd. HA

# GRAIN SIZE DISTRIBUTION

FIGURE D10

## SANDY GRAVEL



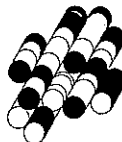
COBBLE SIZE	COARSE	FINE	COARSE	MEDIUM	FINE	SILT and CLAY
	GRAVEL		SAND			

SYMBOL	BOREHOLE	DEPTH (m)	ELEVATION (m)
●	44	1.1	

GSD 1-10-5056 PAVEMENT BH.GPJ 07/26/10

Date July 2010

Project 1-10-5056



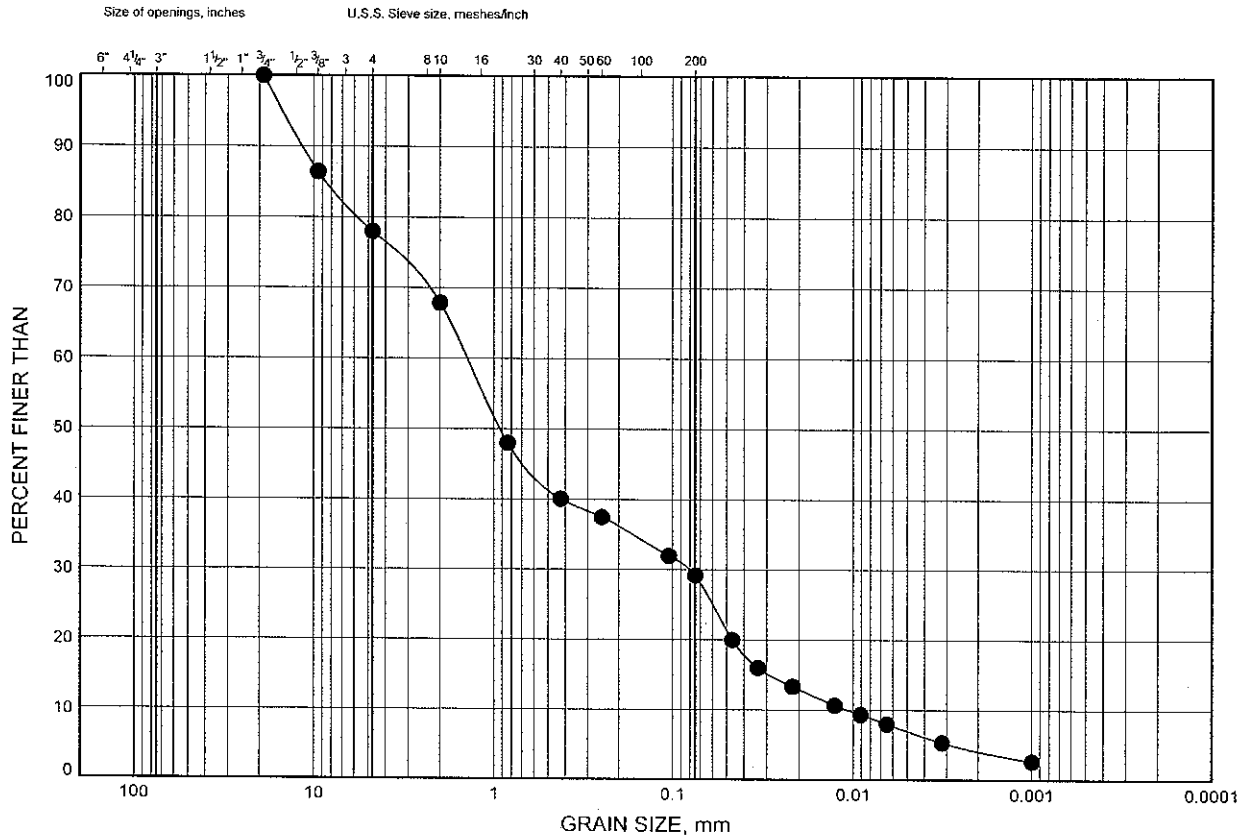
Prep'd DB

Chkd. HA

# GRAIN SIZE DISTRIBUTION

FIGURE D11

## SILTY SAND



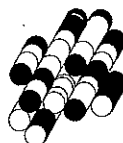
COBBLE SIZE	COARSE	FINE	COARSE	MEDIUM	FINE	SILT and CLAY
	GRAVEL		SAND			

SYMBOL	BOREHOLE	DEPTH (m)	ELEVATION (m)
●	47	1.7	

GSD 1-10-5056 PAVEMENT BH.GPJ 07/26/10

Date July 2010

Project 1-10-5056



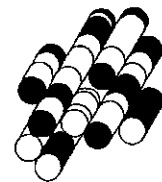
Prep'd DB

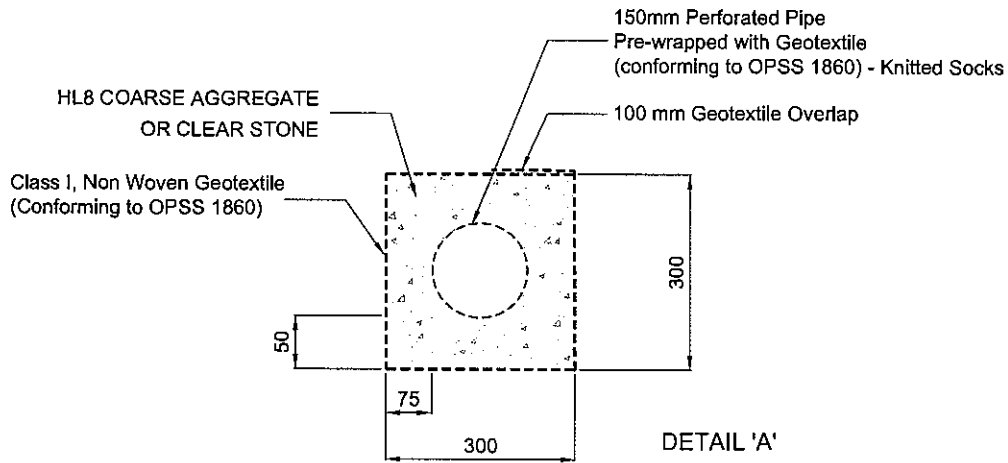
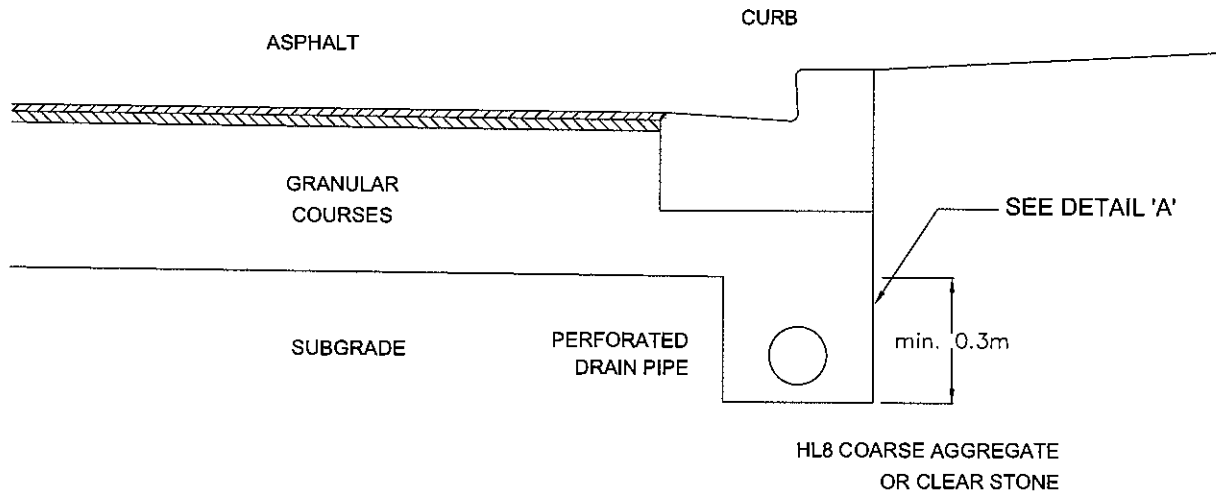
Chkd. HA

# APPENDIX E

## Subdrain Details

**Terraprobe Inc.**





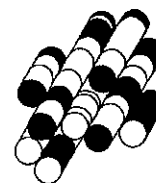
N.T.S.

## SUBDRAIN DETAILS

# **APPENDIX F**

## **Certificates of Chemical Analysis**

**Terraprobe Inc.**





# AGAT Laboratories

**Certificate of Analysis**  
AGAT WORK ORDER: 10T414551  
PROJECT NO: 1-10-5056

5835 COOPERS AVENUE  
MISSISSAUGA, ONTARIO  
CANADA L4Z 1Y2  
TEL (905)712-5100  
FAX (905)712-5122  
http://www.agatlabs.com

CLIENT NAME: TERRAPROBE INC.

ATTENTION TO: Rehman Abdul

Parameter	Unit	G / S	RDL	DATE RECEIVED: Jun 25, 2010		DATE REPORTED: Jul 02, 2010		SAMPLE TYPE: Soil			
				BH2 - SS2 (2.5'-4.5')	BH9 - SS1 (1'-2')	BH15 - SS2 (2'-2.5')	BH26 - SS1 (1'-2')	BH38 - SS2 (2.5'-4.5')	BH49 - SS1 (1'-2')	BH49 - SS2 (2.5'-4.5')	
Antimony	µg/g	1.0	0.8	1843620	1843652	1843660	1843661	1843663	1843664	1843666	1843667
Arsenic	µg/g	14	1	6	4	4	4	5	9	8	8
Barium	µg/g	190	2	174	38	30	27	62	116	103	84
Beryllium	µg/g	1.2	0.5	1.2	<0.5	<0.5	<0.5	<0.5	0.7	0.6	0.5
Boron	µg/g		5	9	6	5	6	9	8	7	6
Boron (Hot Water Extractable)	µg/g		0.10	<0.10	0.28	0.29	0.22	0.32	0.38	0.18	0.16
Cadmium	µg/g		0.5	<0.5	<0.5	<0.5	<0.5	<0.5	<0.5	<0.5	<0.5
Chromium	µg/g	67	2	31	6	28	9	26	19	17	16
Cobalt	µg/g	19	0.5	11.3	3.2	4.8	4.0	5.9	9.6	8.4	9.4
Copper	µg/g	56	1	33	15	23	16	42	46	50	71
Lead	µg/g	55	1	13	11	10	7	28	34	16	16
Molybdenum	µg/g	2.5	0.5	<0.5	<0.5	0.5	<0.5	0.5	0.6	0.6	0.6
Nickel	µg/g	43	1	24	5	7	6	9	17	16	16
Selenium	µg/g	1.4	0.4	0.4	<0.4	0.5	<0.4	<0.4	0.5	<0.4	<0.4
Silver	µg/g	0.35	0.2	<0.2	<0.2	<0.2	<0.2	0.3	<0.2	<0.2	<0.2
Thallium	µg/g	2.5	0.4	<0.4	<0.4	<0.4	<0.4	<0.4	<0.4	<0.4	<0.4
Uranium	µg/g		0.5	0.6	<0.5	<0.5	<0.5	<0.5	<0.5	<0.5	<0.5
Vanadium	µg/g	91	1	42	14	16	19	21	33	28	28
Zinc	µg/g	150	5	57	26	44	38	69	126	73	67
Chromium, Hexavalent	µg/g	2.5	0.2	<0.2	<0.2	<0.2	<0.2	<0.2	<0.2	<0.2	<0.2
Cyanide, Free	µg/g	0.12	0.05	<0.05	<0.05	<0.05	<0.05	<0.05	<0.05	<0.05	<0.05
Mercury	µg/g	0.16	0.01	0.05	0.02	0.02	<0.01	0.03	0.06	0.04	0.03
Electrical Conductivity (2:1)	mS/cm	0.47	0.002	4.86	1.23	1.56	1.22	6.97	7.35	5.37	3.05
Sodium Adsorption Ratio (2:1)	N/A	1.0	N/A	75.7	21.5	19.7	15.9	51.5	103	66.2	58.4
pH, 2:1 CaCl2 Extraction	pH Units			7.85	8.12	7.78	8.00	8.12	8.08	7.99	8.11
Chloride (2:1)	µg/g	58	2	3710	703	917	726	5460	5680	4150	2110
Nitrate + Nitrite	µg/g	40	1	<1	<1	<1	2	4	6	<1	<1

Comments: RDL - Reported Detection Limit; G / S - Guideline / Standard; Refers to T1(AG)

1843620-1843667 EC, SAR, Chloride & Nitrate/Nitrite were determined on the extract obtained from the 2:1 leaching procedure (2 parts DI water:1 part soil).  
pH was determined on the extract obtained from the 2:1 leaching procedure (2 parts 0.01M CaCl2:1 part soil).

*Stony Brook*

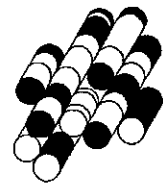
**Certified By:**



# **APPENDIX G**

## **Falling Weight Deflectometer (FWD) Reports**

**Terraprobe Inc.**



July 30, 2010

**FALLING WEIGHT DEFLECTOMETER  
LOAD/DEFLECTION TESTING AND ANALYSIS**

**MISSISSAUGA ROAD AND BUSH STREET  
TOWN OF CALEDON  
REGION OF PEEL**

**Submitted to:**

**Terraprobe Inc.**

**By:**

**Applied Research Associates, Inc.  
5401 Eglinton Avenue West, Suite 105  
Toronto, Ontario  
Telephone: 416-621-9555 Facsimile: 416-621-4917  
Web: [www.ara.com/transportation](http://www.ara.com/transportation)**



**TABLE OF CONTENTS**

1.0 General ..... 1  
2.0 Methodology ..... 1  
3.0 Pavement Layer Thickness and Design Standards ..... 2  
4.0 Analysis Results and Discussion ..... 2  
5.0 Closure ..... 3

APPENDIX A – PAVEMENT THICKNESS INFORMATION

APPENDIX B – DETAILED FWD RESULTS

APPENDIX C – DETAILED FWD RESULT GRAPHS

DRAFT

# FALLING WEIGHT DEFLECTOMETER LOAD/DEFLECTION TESTING AND ANALYSIS

## MISSISSAUGA ROAD AND BUSH STREET TOWN OF CALEDON REGION OF PEEL

### 1.0 General

Applied Research Associates, Inc., was retained by Terraprobe Inc. to complete Falling Weight Deflectometer (FWD) pavement load/deflection testing and data analysis for Mississauga Road and Bush Street in the Town of Caledon, Region of Peel. The FWD testing was completed to determine the present structural condition of the pavement sections. The fieldwork for this project was completed on June 4, 2010.

The FWD tests were completed at 100 m intervals in both lanes, with test locations offset so that a measurement is collected every 50 m along the roadway. Additional tests were completed in locations in areas of localized pavement distresses. The FWD test results were analyzed using the American Association of State Highway and Transportation Officials (AASHTO) procedures.

### 2.0 Methodology

The FWD testing was completed on Mississauga Road between Olde Base Line Road and Bush Street and on Bush Street between Winston Churchill Boulevard and Mississauga Road. Approximately 8 kilometres of roadway was tested. The testing was completed at 50 m intervals, with test locations offset by direction. Additional testing was completed in areas of localized pavement distresses. At each of the test locations, a series of four load applications were applied to the pavement surface. The first application was a "seating" load to ensure the FWD load plate was firmly resting on the pavement surface. The remaining three loads were then applied once at each load level of approximately 30, 40 and 50 kN. The FWD loading plate and sensor configuration are shown in Figure 1. Sensors were located at a distance of 0, 30, 45, 60, 90, 120 and 150 cm from the centre of the loading plate. This sensor configuration was established to permit the use of closed form mathematical solutions to determine the pavement layer properties in accordance with the 1993 AASHTO *Guide for Design of Pavement Structures*.

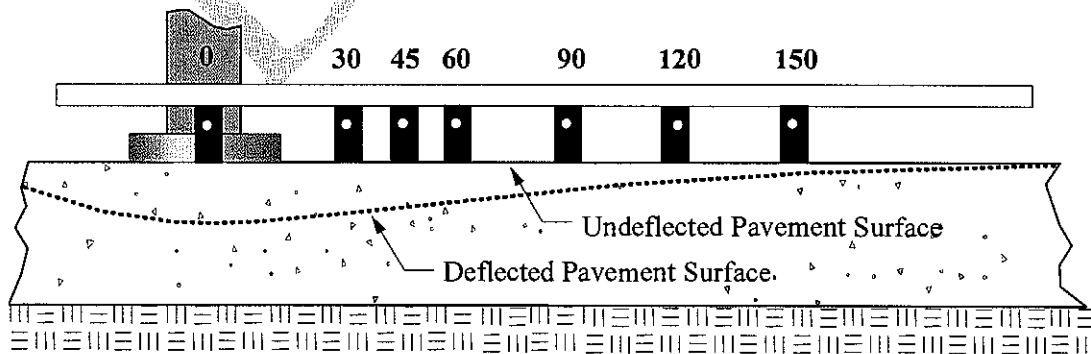


Figure 1. FWD Load Plate and Sensor Configuration.

*Materials Characterization:* The FWD results and the provided layer thickness were used to estimate the stiffness (strength) of the pavement at each of the test locations. Pavement layer stiffness backcalculation uses computer-based models to estimate layer elastic modulus values, given the layer thickness and FWD data.

*Maximum Normalized Deflection.* The maximum deflection ( $D_0$ ), measured in the centre of the load plate, is a good indicator of overall pavement strength. The deflection at this location is a function of the pavement layer stiffness, as well as the support capacity of the subgrade. Because deflection is a function of load and because of slight variations in measured load at each test point, a linear extrapolation of the measured deflection is made to adjust deflections at all test locations to a "standard" load level of 40 kN and temperature of 21°C.

*Backcalculation of Pavement Layer Moduli (AASHTO Methodology)* The pavement deflections measured with the FWD at specific distances from the load plate were used to determine the structural properties of the pavement and subgrade through a process known as backcalculation. Backcalculation uses analytical pavement response models to predict deflections based on a set of given layer thickness and moduli.

The procedure as outlined in the *AASHTO 1993 Guide for Design of Pavement Structures*, Part III, Chapter 5, was used to determine the properties of the as-constructed pavements. The resultant data include the composite elastic modulus ( $E_p$ ) for the combination of all bound layers above the subgrade (e.g., the asphalt concrete and granular bases) and the subgrade resilient modulus ( $M_R$ ).

*Effective Structural Number.* Based on the backcalculated pavement moduli, the effective structural number ( $SN_{EFF}$ ) of the existing pavement was calculated using the *1993 AASHTO Guide for Design of Pavement Structures* procedure. The  $SN_{EFF}$  was compared to the design Structural Number ( $SN_{DES}$ ) required for different roadway classifications. If  $SN_{DES} \leq SN_{EFF}$ , the pavement is considered to be structurally adequate.

### **3.0 Pavement Layer Thickness and Design Standards**

The evaluation of the pavement sections on Mississauga Road and Bush Street was completed using the AASHTO concept of effective structural number ( $SN_{EFF}$ ). The asphalt and granular thickness information used in the backcalculation analysis was provided by Terraprobe Inc. A summary of in-situ pavement thickness information provided to us is presented in Appendix A.

### **4.0 Analysis Results and Discussion**

The average FWD results for Mississauga Road and Bush Street are summarized in Table 2. Table 2 presents the average resilient modulus, composite pavement modulus, and the effective structural number for each roadway as determined by the FWD testing. The detailed FWD results are presented in Appendix B.

The analysis of the FWD testing results proved to be highly variable. The variation in the results can be associated with the highly variable pavement thicknesses that were found along the two sections of roadway that were investigated. There was a clear change in pavement structure on Mississauga Road at approximately 40+500.

**Table 2: Summary of Average FWD Results**

<b>Street</b>	<b>D<sub>0</sub> (µm)</b>	<b>M<sub>r</sub> (MPa)</b>	<b>E<sub>p</sub> (MPa)</b>	<b>SN<sub>Eff</sub> (mm)</b>
Mississauga Road	314	60	815	117
Bush Street	94	10	184	61

### 5.0 Closure

The structural analysis presented in this final report is based on FWD testing completed by ARA, supplemented by the design pavement thickness provided by Terraprobe Inc.. We trust that the information provided in this report is sufficient for your purposes at this time. Should any questions arise, please do not hesitate to contact our office.

**Applied Research Associates, Inc.**

D.J. Swan, M.Eng., P.Eng.  
Project Engineer

APPENDIX A

PAVEMENT THICKNESS INFORMATION

DRAFT

Project Name: Bush St. & Mississauga Rd, Peel Region  
 Project No. : 1-10-5056

July 23, 2010

Sta. No.	BH #	Pavement			Shoulder	Remarks
		Asphalt (mm)	Granular (mm)	TOTAL (mm)	Granular (mm)	
36+950	1	150	560	710	700	Mississauga Rd
37+115	2	180	450	630	680	
37+200	3	150	560	710		
37+445	4	240	480	720		
37+610	5	240	180	420	450	
37+775	6	230	470	700	600	
37+930	7A	150	510	660		
37+995	7B	230	340	570		
38+105	8	170	110	280	320	
38+270	9	250	140	390	320	
38+435	10	150	450	600		
38+601	11	300	300	600		
38+765	12	150	500	650	530	
38+930	13	250	350	600	600	
39+095	14	230	370	600		
39+260	15	250	370	620		
39+425	16	250	460	710		
39+590	17	200	270	470	520	
39+750	18	210	450	660		
39+900	19	130	500	630		
40+085	20	300	30	330	470	
40+250	21	290	290	580		
40+415	22	230	480	710		
40+580	23	180	350	530		
40+745	24	150	560	710	740	
40+910	25	170	240	410	420	
41+075	26	150	440	590		
41+240	27	130	400	530		
41+400	28	150	300	450	420	
41+570	29	100	360	460	430	
41+735	30	100	230	330		
41+900	31	180	430	610		
42+065	32	140	260	400		
42+230	33	110	220	330	440	
42+375	34	120	280	400		
42+560	35	100	370	470		
42+700	36	200	330	530		
42+890	37	180	220	400	410	
2+020	38	200	500	700		Bush Street
1+855	39	150	460	610	620	
1+692	40	180	150	330		
1+525	41	165	280	445		
1+375	42	100	480	560	590	
1+195	43	170	190	360	390	
1+030	44	220	250	470		
0+865	45	370	150	520		
0+700	46	280	280	560	490	
0+535	47	260	330	590	590	
0+370	48	160	240	400		
0+205	49	75	525	600		
-0+040	50	150	490	640	700	



APPENDIX B  
DETAILED FWD RESULTS

DRAFT

**DETAILED FWD RESULTS  
MISSISSAUGA ROAD AND BUSH STREET  
REGION OF PEEL**

Location	Station m	D <sub>0</sub> µm	M <sub>r</sub> MPa	E <sub>p</sub> MPa	SN <sub>eff</sub> mm
Bush Street	0+050	216	99.7	758	97.0
Bush Street	0+100	260	122.3	535	86.4
Bush Street	0+150	251	144.1	531	86.1
Bush Street	0+200	384	71.5	383	77.3
Bush Street	0+250	279	102.7	518	85.4
Bush Street	0+300	343	57.1	497	84.3
Bush Street – Distressed	0+350	325	84.0	453	81.7
Bush Street – Distressed	0+400	335	41.6	619	90.7
Bush Street – Distressed	0+417	276	36.0	965	105.1
Bush Street – Distressed	0+430	258	88.0	618	90.6
Bush Street – Distressed	0+450	554	47.1	271	68.8
Bush Street	0+500	205	55.8	1,159	111.8
Bush Street	0+500	230	34.7	1,412	119.4
Bush Street	0+550	153	50.6	2,195	138.3
Bush Street	0+600	214	60.6	1,019	107.1
Bush Street	0+650	107	63.0	3,584	162.8
Bush Street	0+700	152	73.0	1,605	124.6
Bush Street	0+750	89	72.0	4,626	177.3
Bush Street	0+800	154	46.7	2,356	141.6
Bush Street	0+850	109	70.7	3,066	154.6
Bush Street	0+900	106	60.6	3,860	166.9
Bush Street	0+950	167	62.4	1,536	122.8
Bush Street	1+000	133	71.2	2,086	135.9
Bush Street	1+050	289	72.5	573	88.4
Bush Street	1+100	222	117.1	678	93.5
Bush Street	1+150	193	116.7	831	100.0
Bush Street	1+200	377	53.3	447	81.4
Bush Street	1+250	248	58.8	812	99.2
Bush Street	1+300	392	62.9	392	77.8
Bush Street	1+350	448	80.0	299	71.1
Bush Street	1+400	338	97.1	407	78.8
Bush Street	1+450	334	40.3	636	91.5
Bush Street	1+500	183	41.4	1,872	131.1
Bush Street	1+550	246	97.8	629	91.2
Bush Street	1+600	457	15.6	797	98.7
Bush Street	1+650	186	166.9	752	96.8
Bush Street	1+700	241	33.4	1,338	117.2
Bush Street	1+750	340	87.6	419	79.6
Bush Street	1+800	405	32.1	537	86.5
Bush Street	1+850	386	62.9	400	78.4
Bush Street	1+900	381	76.2	378	76.9
Bush Street	1+950	182	52.8	1,508	122.0
Bush Street	2+000	463	42.4	368	76.3
Bush Street	2+040	114	99.3	2,116	136.6

Note: Stations begin at Winston Churchill Boulevard and increase eastbound.

**DETAILED FWD RESULTS  
MISSISSAUGA ROAD AND BUSH STREET  
REGION OF PEEL**

Location	Station m	D <sub>0</sub> µm	M <sub>r</sub> MPa	E <sub>p</sub> MPa	SN <sub>err</sub> mm
Mississauga Road	36+950	235	100.8	618	130.9
Mississauga Road	37+000	168	117.2	913	149.1
Mississauga Road	37+050	168	97.3	973	152.3
Mississauga Road	37+100	180	68.4	1,016	154.5
Mississauga Road	37+150	144	78.7	1,325	168.8
Mississauga Road - Distressed	37+200	244	97.3	594	129.2
Mississauga Road	37+200	191	85.9	855	145.9
Mississauga Road	37+250	219	80.2	725	138.1
Mississauga Road	37+300	203	74.4	827	144.2
Mississauga Road	37+350	195	64.7	925	149.8
Mississauga Road	37+400	250	29.4	968	152.0
Mississauga Road	37+450	297	25.1	811	143.3
Mississauga Road	37+500	297	30.1	724	138.0
Mississauga Road	37+550	162	117.3	957	151.4
Mississauga Road	37+600	174	70.4	1,056	156.5
Mississauga Road	37+650	267	24.2	992	153.3
Mississauga Road	37+700	240	70.7	669	134.4
Mississauga Road	37+750	244	24.0	1,168	161.8
Mississauga Road	37+800	379	21.9	593	129.1
Mississauga Road	37+850	678	10.7	360	109.4
Mississauga Road	37+900	521	13.0	491	121.3
Mississauga Road - Distressed	37+930	922	9.9	230	94.2
Mississauga Road	37+950	621	13.1	366	110.0
Mississauga Road - Distressed	37+995	554	17.7	369	110.2
Mississauga Road	38+000	359	24.7	601	129.7
Mississauga Road	38+050	242	29.2	1,026	155.0
Mississauga Road	38+100	206	82.0	782	141.6
Mississauga Road	38+150	179	65.2	1,048	156.1
Mississauga Road	38+200	277	23.5	954	151.3
Mississauga Road	38+250	298	82.2	483	120.5
Mississauga Road	38+300	114	131.4	1,480	175.1
Mississauga Road	38+350	151	70.2	1,306	168.0
Mississauga Road	38+400	182	54.5	1,118	159.5
Mississauga Road	38+450	292	24.2	853	145.7
Mississauga Road	38+500	217	71.4	766	140.6
Mississauga Road	38+550	202	54.3	953	151.2
Mississauga Road	38+600	260	44.8	719	137.7
Mississauga Road	38+650	225	34.0	1,047	156.0
Mississauga Road	38+700	245	58.9	697	136.2
Mississauga Road	38+750	222	25.1	1,337	169.3
Mississauga Road	38+800	221	33.9	1,084	157.9
Mississauga Road	38+850	202	31.1	1,338	169.3
Mississauga Road	38+900	292	21.1	940	150.5
Mississauga Road	38+950	222	32.4	1,106	158.9

**DETAILED FWD RESULTS  
MISSISSAUGA ROAD AND BUSH STREET  
REGION OF PEEL**

Location	Station m	D <sub>0</sub> µm	M <sub>r</sub> MPa	E <sub>p</sub> MPa	SN <sub>err</sub> mm
Mississauga Road	39+000	217	55.1	852	145.7
Mississauga Road	39+050	143	54.1	1,644	181.4
Mississauga Road	39+100	365	19.6	677	134.9
Mississauga Road	39+150	467	12.7	604	129.9
Mississauga Road	39+200	318	23.1	762	140.4
Mississauga Road	39+250	272	18.8	1,170	161.9
Mississauga Road	39+300	524	19.7	380	111.3
Mississauga Road	39+350	193	35.3	1,323	168.7
Mississauga Road	39+400	296	37.9	644	132.7
Mississauga Road	39+450	149	53.2	1,545	177.7
Mississauga Road	39+500	371	31.0	510	122.8
Mississauga Road	39+550	219	45.0	933	150.2
Mississauga Road	39+600	346	51.5	457	118.4
Mississauga Road	39+650	231	23.9	1,295	167.5
Mississauga Road	39+700	739	13.6	272	99.6
Mississauga Road - Distressed	39+733	721	16.9	255	97.5
Mississauga Road - Distressed	39+750	711	18.3	251	96.9
Mississauga Road	39+750	495	16.6	456	118.3
Mississauga Road	39+800	419	14.9	648	133.0
Mississauga Road	39+850	360	51.2	434	116.4
Mississauga Road	39+900	213	35.9	1,591	124.2
Mississauga Road	39+950	247	67.9	751	96.7
Mississauga Road	40+000	323	41.5	659	92.6
Mississauga Road	40+050	224	61.8	932	103.9
Mississauga Road	40+100	94	69.4	4,276	172.7
Mississauga Road	40+150	163	86.8	1,256	114.8
Mississauga Road	40+200	187	52.8	1,433	120.0
Mississauga Road	40+250	284	33.2	985	105.9
Mississauga Road	40+300	105	115.9	2,158	137.5
Mississauga Road	40+350	162	61.2	1,648	125.7
Mississauga Road	40+400	109	72.6	3,018	153.8
Mississauga Road	40+450	163	65.3	1,551	123.2
Mississauga Road	40+500	128	82.2	1,987	133.8
Mississauga Road	40+550	304	47.3	669	93.1
Mississauga Road	40+600	233	36.0	1,332	117.1
Mississauga Road	40+650	210	58.9	1,073	108.9
Mississauga Road	40+700	200	144.4	719	95.3
Mississauga Road	40+750	236	179.0	539	86.6
Mississauga Road	40+800	302	114.7	448	81.4
Mississauga Road	40+850	387	45.4	468	82.6
Mississauga Road	40+900	265	147.0	492	84.0
Mississauga Road	40+950	337	122.0	381	77.1
Mississauga Road	41+000	278	54.0	712	95.0
Mississauga Road	41+050	241	111.9	616	90.5
Mississauga Road	41+100	310	112.0	436	80.7

**DETAILED FWD RESULTS  
MISSISSAUGA ROAD AND BUSH STREET  
REGION OF PEEL**

Location	Station m	D <sub>0</sub> µm	M <sub>r</sub> MPa	E <sub>p</sub> MPa	SN <sub>eff</sub> mm
Mississauga Road	41+150	240	117.3	607	90.1
Mississauga Road	41+200	459	57.3	326	73.2
Mississauga Road	41+250	158	125.2	1,078	109.1
Mississauga Road	41+300	197	97.3	879	101.9
Mississauga Road	41+350	299	49.6	669	93.0
Mississauga Road - Distressed	41+400	566	19.4	435	80.6
Mississauga Road - Distressed	41+408	809	31.6	187	60.8
Mississauga Road - Distressed	41+450	283	128.8	470	82.7
Mississauga Road	41+508	510	24.1	444	81.1
Mississauga Road	41+550	319	68.7	507	84.8
Mississauga Road	41+608	322	109.7	417	79.5
Mississauga Road	41+650	254	31.2	1,293	115.9
Mississauga Road	41+708	495	41.3	338	74.1
Mississauga Road	41+750	429	14.3	998	106.3
Mississauga Road	41+808	351	59.3	473	82.9
Mississauga Road	41+850	361	45.4	522	85.6
Mississauga Road	41+908	380	42.5	499	84.4
Mississauga Road	41+950	348	52.4	509	85.0
Mississauga Road	42+008	276	79.3	585	89.0
Mississauga Road	42+050	395	52.9	419	79.6
Mississauga Road	42+108	378	70.3	394	78.0
Mississauga Road	42+150	212	77.3	886	102.2
Mississauga Road	42+208	387	26.8	665	92.9
Mississauga Road	42+250	356	84.5	399	78.3
Mississauga Road	42+308	293	93.7	501	84.5
Mississauga Road - Distressed	42+328	506	64.5	273	69.0
Mississauga Road	42+350	357	111.6	363	75.9
Mississauga Road - Distressed	42+375	451	49.1	357	75.5
Mississauga Road	42+408	339	87.8	421	79.7
Mississauga Road	42+450	394	96.3	334	73.8
Mississauga Road	42+500	264	91.9	587	89.1
Mississauga Road	42+550	388	54.0	427	80.1
Mississauga Road	42+600	247	89.5	653	92.3
Mississauga Road	42+650	198	52.9	1,289	115.8
Mississauga Road	42+700	283	61.0	646	92.0
Mississauga Road	42+750	161	82.9	1,322	116.8
Mississauga Road	42+800	778	37.7	184	60.5
Mississauga Road	42+850	514	103.5	233	65.5
Mississauga Road	42+900	458	69.9	303	71.5
Mississauga Road	42+950	336	84.5	431	80.4
Mississauga Road	43+000	599	62.1	221	64.3

Note: Stations begin at Olde Base Line Road and increase northbound.

APPENDIX C  
DETAILED FWD RESULT GRAPHS

DRAFT

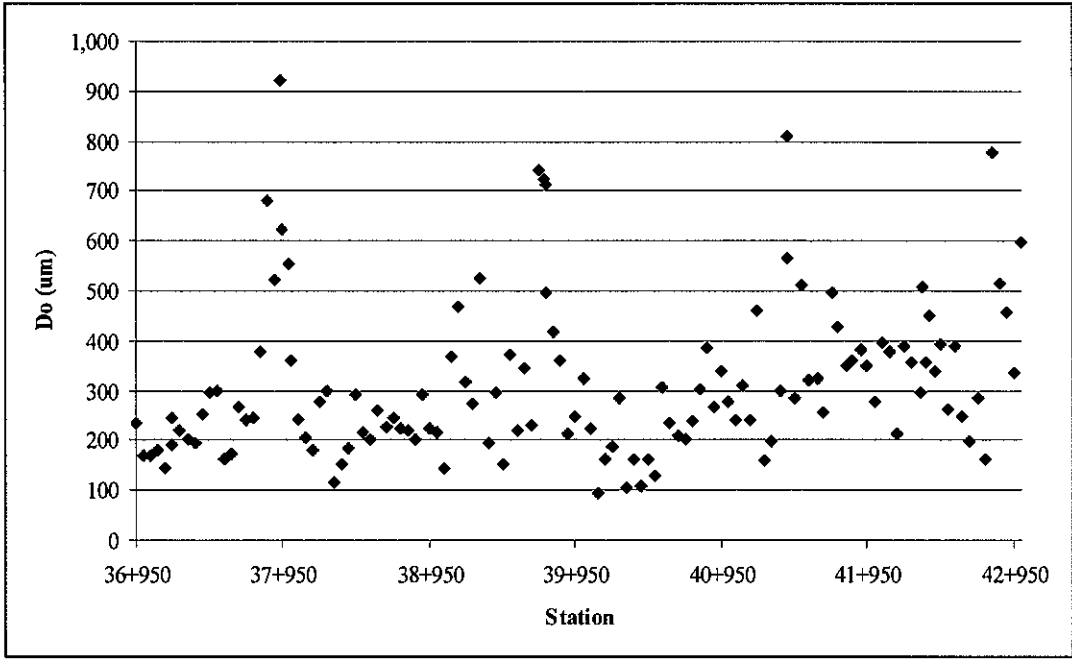


Figure 1: Normalized deflection (µm) – Mississauga Road

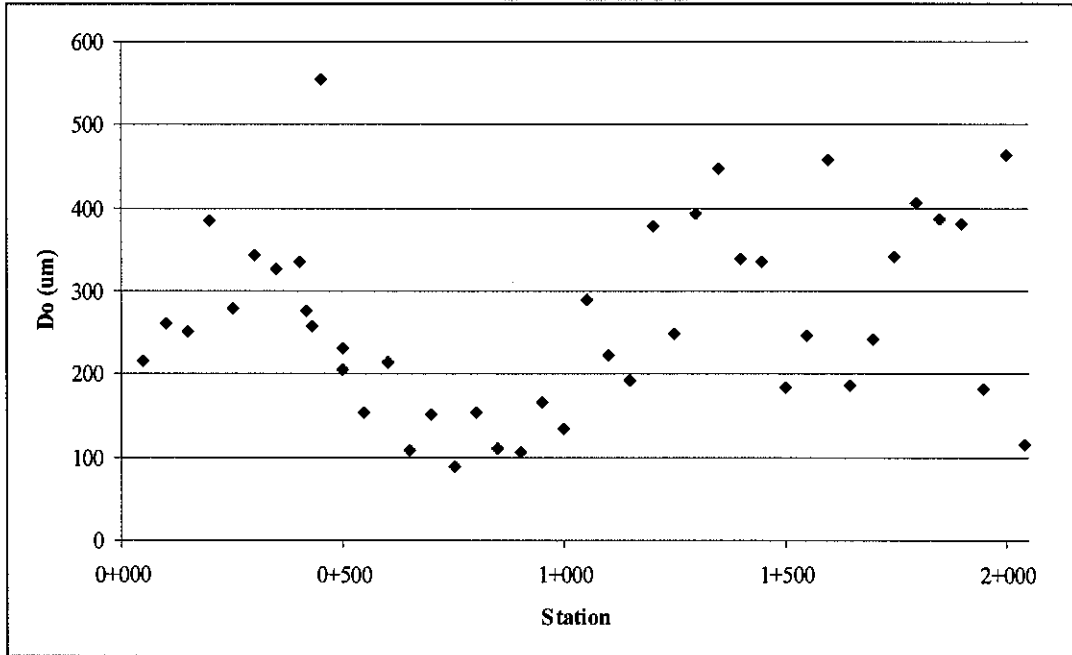


Figure 2: Normalized deflection (µm) – Bush Street

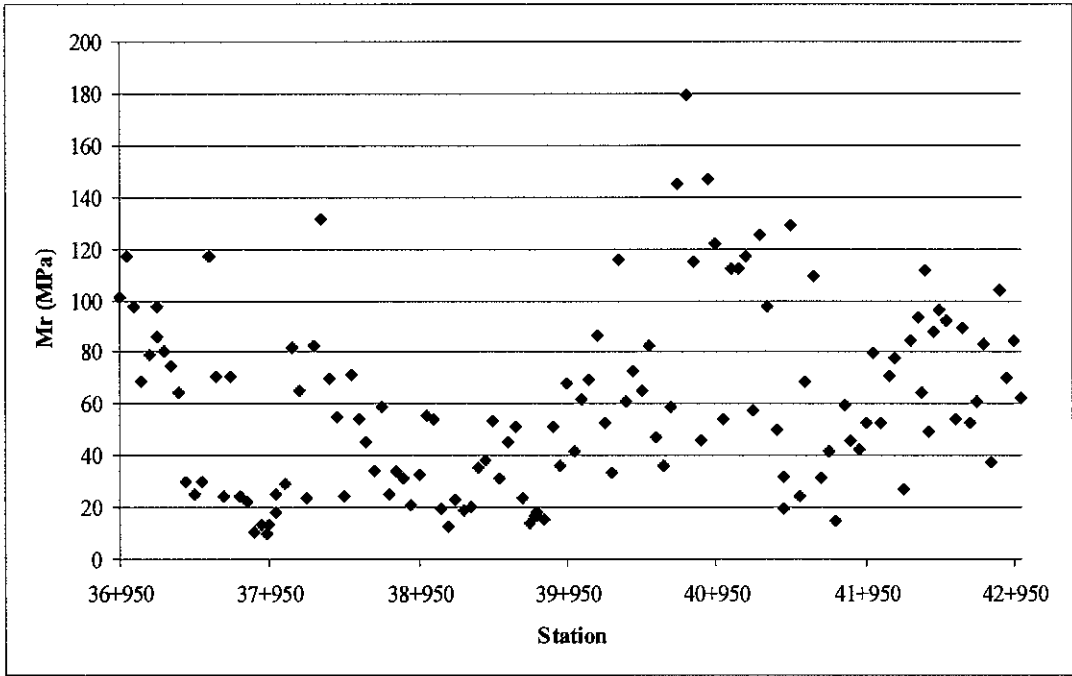


Figure 3: Resilient modulus (MPa) – Mississauga Road

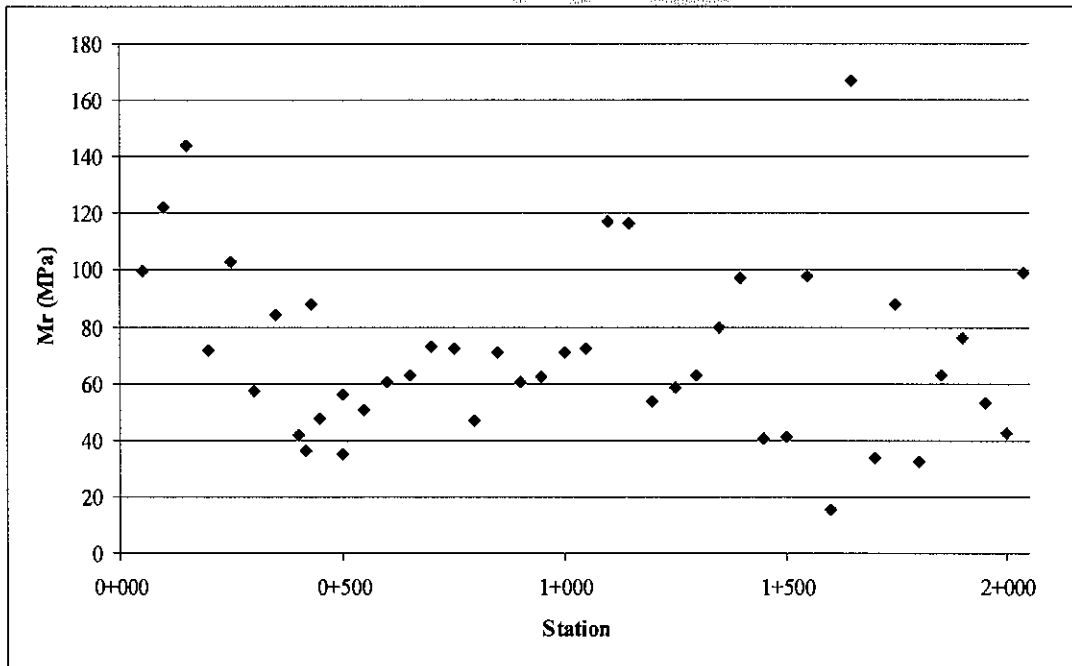


Figure 4: Resilient modulus (MPa) – Bush Street



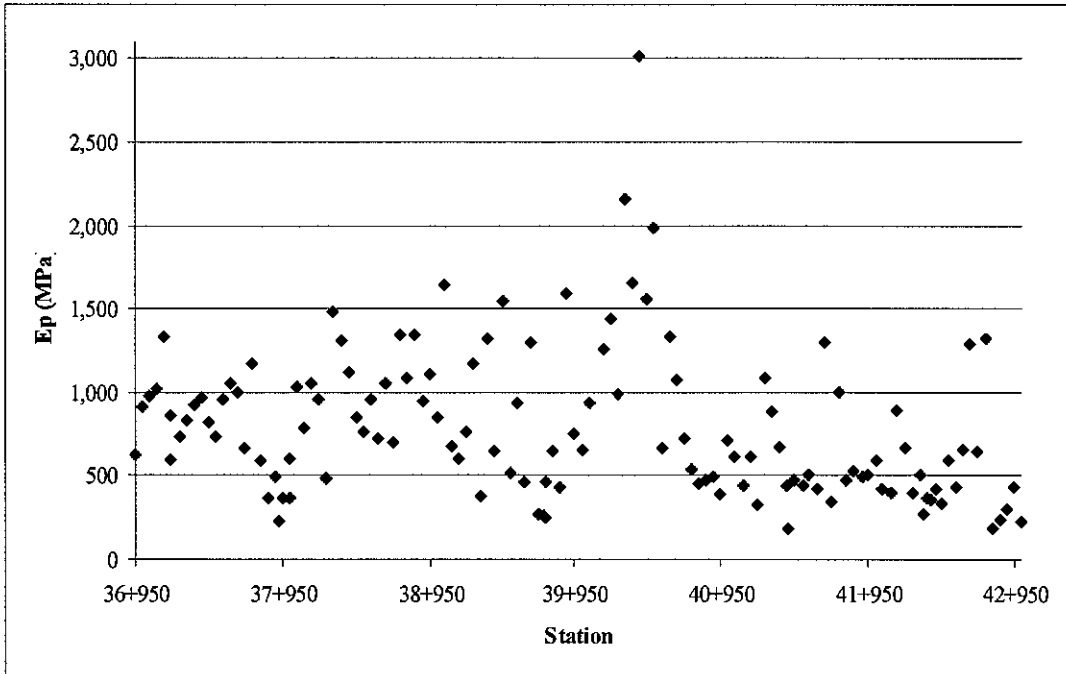


Figure 5: Composite pavement modulus (MPa) – Mississauga Road

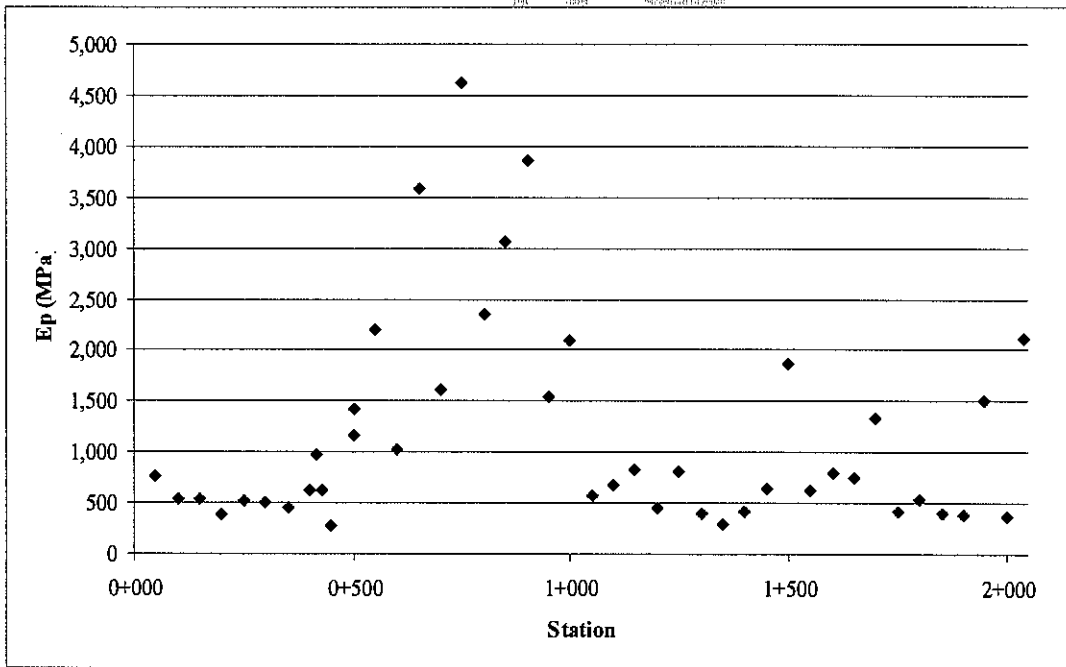


Figure 6: Composite pavement modulus (MPa) – Bush Street

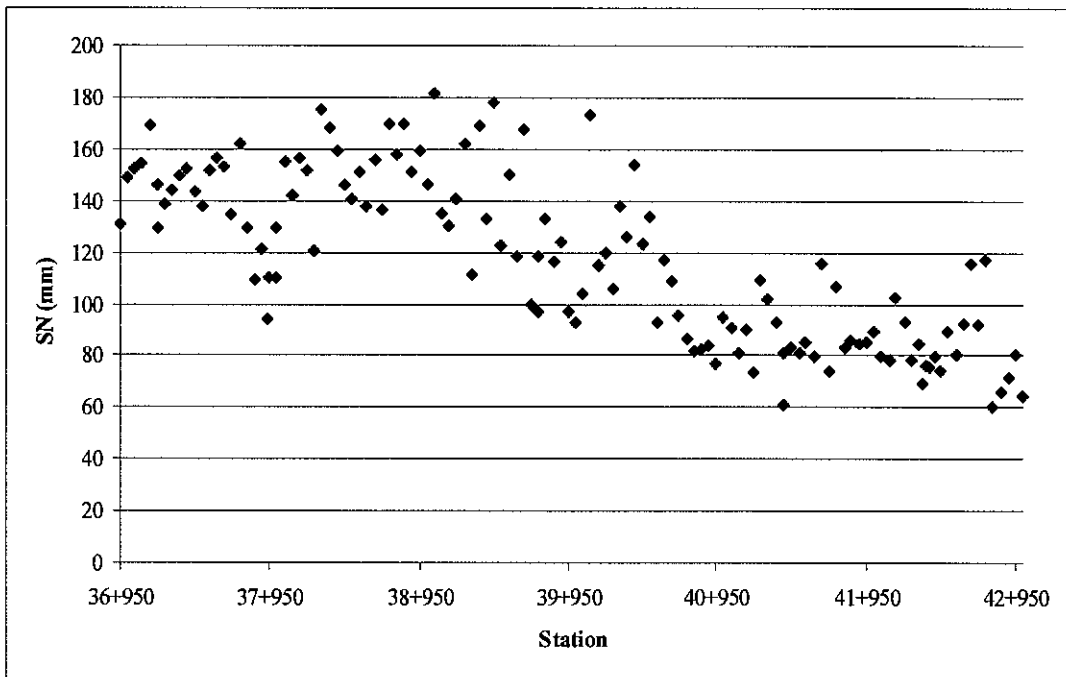


Figure 7: Effective structural number (mm) – Mississauga Road

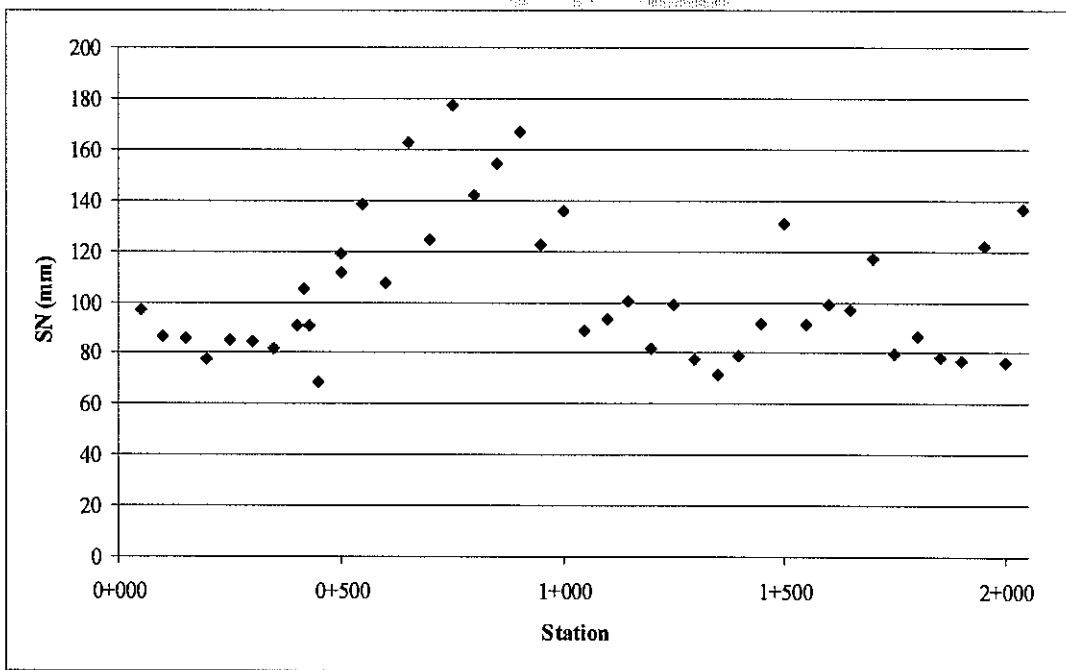


Figure 8: Effective structural number (mm) – Bush Street

The pavements on Mississauga Road were re-designed based on more recent traffic information and drawings obtained from the Region of Peel.

The pavement structure of Mississauga Road (Page 5 of our report of August 06, 2010) is:

Location	Main Lanes Average Thickness (mm)			Shoulders Average Thickness (mm)
	HMA	Granular	Total	Granular
Sta. 36+900 – 37+325	160	525	685	690
Sta. 37+325 – 37+850	240	375	615	525
Sta. 37+850 – 38+850	200	335	535	390
Sta. 38+850 – 39+900	230	380	610	560
Sta. 39+900 – 40+500	275	265	540	470
Sta. 40+500 – 43+030	145	335	480	425

Flexible pavement designs for new construction and rehabilitation were completed and outlined below are the pavement design parameters and traffic data used for our designs.

DESIGN PARAMETER	Mississauga Road
Initial/Terminal Serviceability Index	$P_t = 4.2$ $p_i = 2.2$
Loss in Serviceability index	2.0
Desired Reliability (%) and Standard Deviation	R = 85      SD = 0.44
Estimated Elastic Modulus of Subgrade Soil (MPa)	20 (Mississauga Road)
Estimated Cumulative ESALS (20 yr Design Period)	206,720
Layer Coefficients of Hot Mix Asphalt (HMA)	New HMA = 0.42      Existing HMA = 0.25
	Gran A = 0.14 Gran B Type I = 0.09 Rap/Granular A blend = 0.14 Existing Granular A = 0.12 Existing Granular B = 0.07

Layer Coefficient of Granular Materials	
Drainage Coefficient	m = 1 (new granular base & subbase) m = 0.9 (existing granular)

The following references and guidelines were used for the pavement designs.

- MTO's "Adaptation and Verification of AASHTO Pavement Design Guide for Ontario Conditions", MI-183, March 2008.
- AASHTO Guide for the Design of Pavement Structures, 1993.
- "Procedures for Estimating Traffic Loads for Pavement Designs", Hajek J., 1995.

The flexible pavement was designed using AASHTOWare DARWin 3.1, a proprietary pavement design software.

Based on the design traffic (206,720 ESAL's) the recommended pavement structure for new construction is:

HMA	125mm (50mm HL-1 or Superpave 12.5 FC1 surface course and 75mm HL-8 or Superpave 19 Binder Course)
Granular A	150mm
Granular B	400mm
Total Thickness	675mm
GBE	667mm

The structural capacities of the existing north bound and south bound lanes of Mississauga Road were assessed for the design traffic loads and the pavement structure was found to be inadequate at some locations. Milling & paving the existing roadway is not recommended as a rehabilitation treatment given the age of the existing pavement and the existence of relatively weak subgrade soils at some sections of the alignment.

Based on the proposed design profile the following rehabilitation treatments are considered to be feasible.

Mississauga Road Rehabilitation (Sta. 36+900 to Sta. 43+060)			
Full Depth Reconstruction	Full Depth Asphalt Replacement	Cold In Place Pulverization (CIP)	Remarks
	36 + 900 – 37 + 325	36 + 900 – 37 + 325 (Mill 35mm)	Only Gran A to be used for Grade Raise
37 + 325 – 37 + 390			
	37 + 390 – 37 + 850	37 + 390 – 37 + 850 (Mill 115mm)	Only Gran A to be used for Grade Raise
37 + 850 – 38 + 010			
	38 + 010 – 38 + 070	38 + 010 – 38 + 070 (Mill 75mm)	Only Gran A to be used for Grade Raise
38 + 070 – 38 + 195			
	38 + 195 – 38 + 465	38 + 195 – 38 + 465 (Mill 75mm)	Only Gran A to be used for Grade Raise
38 + 465 – 38 + 520			
	38 + 520 – 38 + 640	38 + 520 – 38 + 640 (Mill 75mm)	Only Gran A to be used for Grade Raise
38 + 640 – 38 + 700			
	38 + 700 – 38 + 800	38 + 700 – 38 + 800 (Mill 75mm)	Only Gran A to be used for Grade Raise

38 + 800 – 38 + 920			
	38 + 920 – 39 + 985	38 + 920 – 39 + 985 (Mill 105mm)	Only Gran A to be used for Grade Raise
39 + 985 – 39 + 065			
	39 + 065 – 39 + 140	39 + 065 – 39 + 140 (Mill 105mm)	Only Gran A to be used for Grade Raise
39 + 140 – 39 + 170			
	39 + 170 – 39 + 370	39 + 170 – 39 + 370 (Mill 105mm)	Only Gran A to be used for Grade Raise
39 + 370 – 39 + 505			
	39 + 505 – 39 + 900	39 + 505 – 39 + 900 (Mill 105mm)	Only Gran A to be used for Grade Raise
	39 + 900 – 40 + 500	39 + 900 – 40 + 500 (Mill 150mm)	Only Gran A to be used for Grade Raise
	40 + 500 – 40 + 690	40 + 500 – 40 + 690 (Mill 20mm)	Only Gran A to be used for Grade Raise
40 + 690 – 40 + 730			
	40 + 730 – 41 + 420	40 + 730 – 41 + 420 (Mill 20mm)	Only Gran A to be used for Grade Raise
41 + 420 – 41 + 485			
	41 + 485 – 42 + 080	41 + 485 – 42 + 080 (Mill 20mm)	Only Gran A to be used for Grade Raise
42 + 080 – 42 + 100			
	42 + 100 – 42 + 680	42 + 100 – 42 + 680 (Mill 20mm)	Only Gran A to be used for Grade Raise
42 + 680 – 42 + 755			
	42 + 755 – 42 + 815	42 + 755 – 42 + 815 (Mill 20mm)	Only Gran A to be used for Grade Raise
42 + 815 + 42 + 850			
	42 + 850 – 42 + 950	42 + 850 – 42 + 950 (Mill 20mm)	Only Gran A to be used for Grade Raise
42 + 950 – 42 + 965			
	42 + 965 – 43 + 040	42 + 965 – 43 + 040 (Mill 20mm)	Only Gran A to be used for Grade Raise
43 + 040 – 43 + 060			

The construction methodology for full depth reconstruction is:

- Remove existing pavement full depth
- Reconstruct roadway with 125mm HMA, 150mm Granular A, and 400mm Granular B

The construction methodology for full depth asphalt replacement is:

- Remove existing HMA full depth.
- Compact existing unbound granular
- Place and compact Granular A as and where required to achieve design profile of HMA/Base interface.
- Repave with 125mm HMA

The construction methodology for Cold in Place Pulverization is:

- Mill existing HMA to achieve a thickness of 125mm.
- Pulverize and blend existing 125mm HMA with 125mm of underlying unbound granular
- Grade and compact Rap/Granular blend.
- Place and compact Granular A as and where required to achieve design profile of HMA/Base interface.
- Pave with 125mm HMA

It is noted that the existing pavement in most areas can be rehabilitated either by full depth asphalt replacement or cold in place pulverization. We would recommend that the Region consider Cold in Place Pulverization as the rehabilitation option.

Some of the advantages of CIP are:

- Existing asphalt can be re-cycled and re-used on site.
- Pavements have a higher probability of performing better (compared to full depth asphalt replacement) because the pulverization and mixing process will produce a uniform strong Rap/Granular layer within the new pavement structure.

Terraprobe

The pavements on Bush Street were re-designed based on more recent traffic information obtained from the Region of Peel.

The pavement structure of Bush Street (Page 7 of our report of August 06, 2010) is:

Location	Main Lanes Average Thickness (mm)			Shoulders Average Thickness (mm)
	HMA	Granular	Total	Granular
Sta. -0+044 – 0+450	155	365	520	700
Sta. 0+450 – 0+950	305	255	560	540
Sta. 0+950 – 2+070	170	325	495	535

Flexible pavement designs for new construction and rehabilitation were completed and outlined below are the pavement design parameters and traffic data used for our designs.

DESIGN PARAMETER	BUSH Street
Initial/Terminal Serviceability Index	$P_t = 4.2$ $p_i = 2.2$
Loss in Serviceability index	2.0
Desired Reliability (%) and Standard Deviation	R = 85      SD = 0.44
Estimated Elastic Modulus of Subgrade Soil (MPa)	25 (Bush Street)
Estimated Cumulative ESALS (20 yr Design Period)	167,285
Layer Coefficients of Hot Mix Asphalt (HMA)	New HMA = 0.42      Existing HMA = 0.25 Gran A = 0.14 Gran B Type I = 0.09 Rap/Granular A blend = 0.14 Existing Granular A = 0.12 Existing Granular B = 0.07

Layer Coefficient of Granular Materials	
Drainage Coefficient	m = 1 (new granular base & subbase) m = 0.9 (existing granular)

The following references and guidelines were used for the pavement designs.

- MTO's "Adaptation and Verification of AASHTO Pavement Design Guide for Ontario Conditions", MI-183, March 2008.
- AASHTO Guide for the Design of Pavement Structures, 1993.
- "Procedures for Estimating Traffic Loads for Pavement Designs", Hajek J., 1995.

The flexible pavement was designed using AASHTOWare DARWin 3.1, a proprietary pavement design software.

Based on the design traffic (167,285 ESAL's) the recommended pavement structure for new construction is:

HMA	125mm (50mm HL-1 or Superpave 12.5 FC1 surface course and 75mm HL-8 or Superpave 19 Binder Course)
Granular A	150mm
Granular B	400mm
Total Thickness	675mm
GBE	667mm

A structural number of 81mm is required for a service life extension of 20years. Structurally deficient pavement exists between Sta. -0+044 to 0+450 (SN existing of 75mm) and from Sta. 0+950 to Sta. 2+070 (SN existing of 77mm).

It is noted that the design profile of Bush Street will be raised for most of the alignment, except between Sta. 1+350 and Sta. 1+420 where a cut is proposed.

Based on the proposed design profile the following rehabilitation treatments are considered to be feasible.

Bush Street Rehabilitation (Sta. -0+044 to Sta. 2+070)				
Treatment	Other Treatments	Full Depth Asphalt Replacement	Cold In Place Pulverization	Remarks
Sta. -0+044 to Sta. 0+000	Mill 50mm and Repave with 50mm HMA	Remove asphalt full depth. Compact existing granular then place and compact Granular A as required to achieve design profile of HMA/Base interface. Repave with 125mm HMA		Recommend Full Depth Asphalt Replacement
		Remove asphalt full depth. Compact existing granular then place and	Mill existing HMA to 125mm thick (mill 30mm). Pulverize and blend 125mm HMA with 125mm of unbound	Construction costs



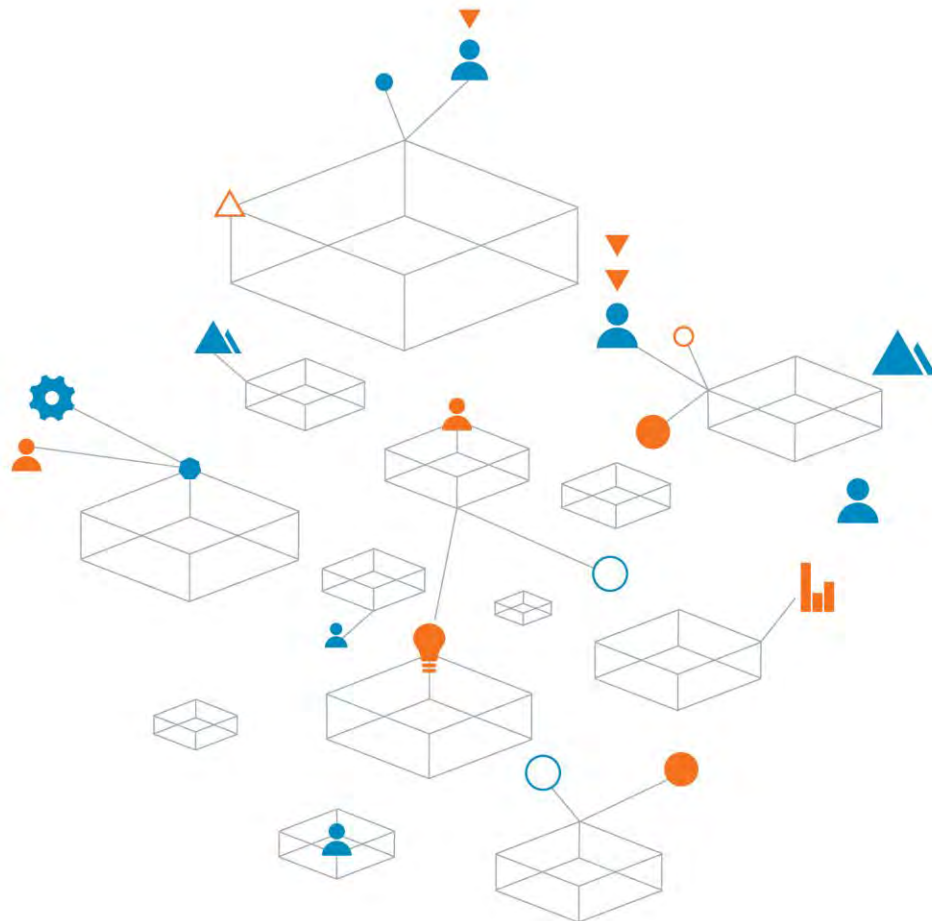
Sta. 0+000 to Sta. 0+450		compact Granular A to achieve design profile of HMA/Base interface. Repave with 125mm HMA	granular then grade and compact Rap/Granular Blend. Raise grade to achieve design profile of HMA/Base interface by placing and compacting Granular A. Pave with 125mm HMA	will govern which option is chosen (Region to choose preferred option)
Sta. 0+450 to Sta. 0+950		Remove asphalt full depth. Compact existing granular then place and compact Granular A to achieve design profile of HMA/Base interface. Repave with 125mm HMA	Mill existing HMA to 125mm thick (mill 180mm). Pulverize and blend 125mm HMA with 125mm of unbound granular then grade and compact Rap/Granular Blend. Raise grade to achieve design profile of HMA/Base interface by placing and compacting Granular A. Pave with 125mm HMA	Construction costs will govern which option is chosen (Region to choose preferred option)
Sta. 0+950 to Sta. 1+350		Remove asphalt full depth. Compact existing granular then place and compact Granular A to achieve design profile of HMA/Base interface. Repave with 125mm HMA	Mill existing HMA to 125mm thick (mill 45mm). Pulverize and blend 125mm HMA with 125mm of unbound granular then grade and compact Rap/Granular Blend. Raise grade to achieve design profile of HMA/Base interface by placing and compacting Granular A. Pave with 125mm HMA	Construction costs will govern which option is chosen (Region to choose preferred option)
Sta. 1+350 to Sta. 1+420	Full depth reconstruction (125mm HMA, 150 Gran A and 400 Gran B)			
Sta. 1+420 to Sta. 2+070		Remove asphalt full depth. Compact existing granular then place and compact Granular A to achieve design profile of HMA/Base interface. Repave with 125mm HMA	Mill existing HMA to 125mm thick (mill 45mm). Pulverize and blend 125mm HMA with 125mm of unbound granular then grade and compact Rap/Granular Blend. Raise grade to achieve design profile of HMA/Base interface by placing and compacting	Construction costs will govern which option is chosen (Region to choose preferred option)

			Granular A. Pave with 125mm HMA	
--	--	--	------------------------------------	--

Terraprobe

**Appendix U.2**  
**Geotechnical and Pavement Assessment**  
**for Winston Churchill Boulevard and**  
**Olde Base Line Road**

**HDR Corporation  
Geotechnical Investigation for Environmental  
Assessment Study Improvements to Regional Road  
Corridor Bounded By Winston Churchill Blvd., Bush St.,  
Olde Base Line Rd., Mississauga Rd., and Old Main St.  
GEOTETOB21649AA Rev. 3  
28 February 2014**



Trust is the  
cornerstone  
of all our  
projects



20 Meteor Drive  
Toronto, Ontario  
M9W 1A4 Canada  
t: 416 213 1255  
f: 416 213 1260  
coffey.com

February 28, 2014

HDR Corporation  
100 York Boulevard, Suite 300  
Richmond Hill, ON L4B 1J8

**Attention: Mr. Tyrone Gan, P. Eng.**

Dear Mr. Gan,

**RE: Geotechnical Investigation for Environment Assessment Study  
Improvements to Regional Road Corridor Bounded by Winston Churchill Blvd., Bush St., Old  
Main St., Mississauga Rd., Olde Base Line Rd.  
Wellington, Regional Municipality of Peel  
Peel Project 11-4360**

Please find enclosed a copy of our Geotechnical Investigation Report for the proposed Improvements to Regional Corridor in relation to the above project.

If you have any comments or queries regarding this report please contact the undersigned.

For and on behalf of Coffey

A handwritten signature in blue ink, appearing to read "Bill Feng".

**Bill Feng, P.Eng.**  
Associate Geotechnical Engineer

Distribution: Coffey Geotechnics Inc.  
HDR Corporation  
HDR Corporation

Original  
3 hard copies  
1 electronic copy (PDF format)

# CONTENTS

<b>1</b>	<b>INTRODUCTION</b>	<b>1</b>
<b>2</b>	<b>PROJECT SUMMARY</b>	<b>1</b>
<b>2.1</b>	<b>Published Geology</b>	<b>2</b>
<b>2.2</b>	<b>Site Settings, Project Limits and Major Landmarks</b>	<b>2</b>
<b>2.3</b>	<b>Project Scope, Design Objectives and Special Features</b>	<b>3</b>
<b>3</b>	<b>GROUND INVESTIGATION METHODOLOGY</b>	<b>4</b>
<b>3.1</b>	<b>Review of roads construction history</b>	<b>5</b>
<b>3.2</b>	<b>Review of previous investigations</b>	<b>5</b>
<b>3.3</b>	<b>Visual Pavement Assessment</b>	<b>5</b>
<b>3.4</b>	<b>Confirmatory Pavement Borehole Investigation</b>	<b>5</b>
<b>3.5</b>	<b>Geotechnical Confirmatory Testing</b>	<b>6</b>
<b>4</b>	<b>PAVEMENT SURFACE AND SUBSURFACE CONDITIONS</b>	<b>7</b>
<b>4.1</b>	<b>Existing Pavement Conditions</b>	<b>7</b>
<b>4.2</b>	<b>Field Investigation Data and Laboratory Testing Results</b>	<b>14</b>
<b>4.3</b>	<b>Pavement Structural Deficiency Analyses</b>	<b>25</b>
<b>5</b>	<b>PRELIMINARY PAVEMENT REHABILITATION STRATEGY</b>	<b>29</b>
<b>5.1</b>	<b>Traffic Data</b>	<b>29</b>
<b>5.2</b>	<b>Design Criteria and Primary Considerations</b>	<b>29</b>
<b>5.3</b>	<b>Other Considerations</b>	<b>32</b>
<b>6</b>	<b>LIMITATIONS OF REPORT</b>	<b>33</b>
<b>7</b>	<b>CLOSURE</b>	<b>34</b>

# CONTENTS

## **Drawings**

- Drawing 1: Site Location Plan
- Drawing 2: Borehole Location Plan

## **Appendices**

- Appendix A: Explanation Sheets and Borehole Logs
- Appendix B: Geotechnical Laboratory Testing Results
- Appendix C: Pavement Core Logs and Core Photographs
- Appendix D: Important Information about your Coffey Report

# 1 INTRODUCTION

Coffey Geotechnics Inc. (Coffey) was retained by HDR Corporation (HDR) on behalf of Regional Municipality of Peel (Peel) to carry out a geotechnical investigation and subsequent interpretative reporting for Project 11-4360 of Peel's proposed Improvements to Regional Corridor. It is understood from the Project Terms of Reference (ToR) that the current engineering study is a continuation of the Municipal Class EA study (for Bush Street and Mississauga Road, Peel Project 09-4370). The geotechnical objective is to provide a preliminary pavement review (performance and deficiency) to assist the 30% detail design for the proposed service improvements for the Regional Road Corridor. The pavement study for this stage includes the following roadway sections:

- Olde Base Line Road from Winston Churchill Boulevard to Mississauga Road
- Winston Churchill Boulevard from Olde Base Line Road to Bush Street

The purposes of the investigation were to determine the existing pavement structure and subsurface conditions at the site (determining the existing pavement deficiencies), and provide preliminary geotechnical engineering recommendations to assist in the current design stage (30%) of the proposed improvements works.

According to the project ToR, the relevant findings and recommendations from the previous study(ies) (Project 09-4370) are to be incorporated and integrated into this study. It is important to note that the data from Project 09-4370 is attached where necessary in this report for reference. However, Coffey has not verified the data accuracy, nor the validation of the modelling (and analyses), nor the suitability of the recommendations from the previous study(ies).

A limited scope of culvert condition survey, and a preliminary Hydrogeological Investigation have also been carried out in conjunction with the geotechnical study. The data reports will be submitted under separate covers.

This report contains the findings of the geotechnical field investigation and subsequent laboratory testing together with our geotechnical engineering comments and considerations for road rehabilitation needs within the project area. This report has been prepared for HDR, Peel Region, their engineers and their designers in relation to Peel Project 11-4360. Further dissemination of this report is not permitted without Coffey's prior written approval.

# 2 PROJECT SUMMARY

As per the Peel Region ToR for this assignment (Section 2 of RFP 2011-066P ToR), the main scope of the current assignment is to identify the existing pavement deficiencies to assist in completion of the 30% detail design. The preliminary investigation presented in this report provides the results of a field and laboratory investigation and, where necessary, expands the scope to further provide the preliminary pavement design and rehabilitation considerations for the following project roadway sections:



Peel Region Project Number: 11-4360

Project location: Olde Base Line Road from Winston Churchill Boulevard to Mississauga Road  
Winston Churchill Boulevard from Olde Base Line Road to Bush Street

A previous investigation was carried out by Terraprobe Limited (Terraprobe) for pavement components on Mississauga Road, Olde Main Street and Bush Street, and documented in a Draft Pavement Design Report dated August 06, 2010 and an addendum email dated January 26, 2011. Findings and design data for these roadway sections should be referred to the captioned report and relevant document.

This report is developed on the basis of our current investigation and scope of work. It should be read as a standalone report.

## 2.1 Published Geology

The bedrock beneath the site, unconformably overlying the Queenston Formation, are rocks of sandstone, dolostones and limestones interbedded with shales of Cararact Group of Lower Silurian Formation as per the Ontario Ministry of Natural Resources Map M2326 “*Southern Ontario Orangeville Quaternary Geology*” and the accompanying Geoscience Report No. 141 “*Quaternary Geology of the Orangeville Area, Southern Ontario*”. It is indicated that bedrock topography varies quite significantly in the area near Belfountain.

Surficial geology along Mississauga Road and Winston Churchill Boulevard is understood to largely comprise stone-poor, sandy silt to silty sand till (Wentworth Till). Bedrock outcrops or thin overburden (shaly till) over bedrock may be present at shallow depth along most of Olde Base Line Road. To the north of the site (near Bush Street), the near surface soil may consist of glaciofluvial (river) deposits.

The general topography in Belfountain-Caledon area is flat to gently rolling. The areal highest point is 5 km west-northwest of Orangeville which slopes gently down from north to south. Locally, bedrock channels in the Cataract-Belfountain form reliefs, with drumlin field regions being present in the site central areas.

No groundwater information was found during our desktop study.

## 2.2 Site Settings, Project Limits and Major Landmarks

The site is located within a rural area in the south of Town of Caledon, Ontario.

A Site Location Plan is presented as **Drawing 1** to this report.

Based on Peel Region’s Terms of Reference, both Winston Churchill Blvd and Olde Base Line within the project limits are two-lane rural arterial roads.

The approximate chainages listed apply to the investigation (Project Stationing and Limits):

Winston Churchill Blvd	Station 0+000	Olde Base Line (south limit of WCB)
	Station 6+000	Bush Street (north limit of WCB)
Olde Base Line	Station 0+000	Winston Churchill Blvd (west limit of OBL)
	Station 2+700	Mississauga Road (east limit of OBL)

## 2.3 Project Scope, Design Objectives and Special Features

### 2.3.1 Project Scope

At the current stage as an EA component, no detailed development plan is defined. The assignment is to identify the existing pavement deficiencies based on the visible distresses and riding quality (determined by visual pavement assessment), and evaluate its structural competency based on the intrusive pavement investigation.

No other special design features, e.g. urbanization, modification of alignments, intersection improvements, culvert replacements, etc., are included at this stage.

The drainage configurations will remain generally unchanged. It is however, necessary to improve existing drainage conditions at local areas, where identified.

### 2.3.2 Investigation Standards and Design Criteria

The site is located within a rural area in the south of Town of Caledon, Ontario.

A complete traffic study has not been completed at the time of the preparation of the report. As a base assumption for this study (and confirmed by HDR and Peel Region), significant traffic growth and road capacity improvements are not anticipated (Section 4.5 of ToR).

For pavement assessment and design purposes, relevant design and investigation standards are provided below (based on the project ToR and clarification with Peel Region):

Minimum Design Criteria and Construction Standards	Referenced Investigation and Design Standards
To be developed/completed as part of Phase III of EA (Section 5.4 of ToR)	<ul style="list-style-type: none"> <li>• Peel Region Road Standards (non-existent)</li> <li>• Pavement Assessment Standards (MTO Flexible Pavement Distress Manifestation for Municipal Applications)</li> <li>• Project Specific Design Criteria (MTO Pavement Design and Rehabilitation Manual GBE Method)</li> <li>• Project Specific Design Criteria (AASHTO-MTO Methods)</li> </ul>

### 2.3.3 Traffic Data

The following traffic information is provided for the current study:

	Winston Churchill Boulevard	Olde Base Line Road
Count Year	2012	2012
AADT (2011)	2147	2230
Annual growth factor	2% assumed	2% assumed
Commercial Vehicle Ratio (maximum)	6%	3%

## 3 GROUND INVESTIGATION METHODOLOGY

The scope of this geotechnical investigation, including the associated laboratory testing and reporting, has been carried out in general accordance with Coffey's existing term contract with the client.

The procedures outlined herein include the following office, field and laboratory components:

1. Review of roads construction history, including initial construction as-built drawings, major rehabilitation events (year and methodology), reconstruction details (year and methodology), major maintenance activities (year and maintenance details);
2. Review of previous investigations;
3. Carry out a visual pavement condition assessment;
4. Carry out a confirmatory pavement borehole investigation (intrusive) based on the information collected through steps 1 to 3 (targeting poor performance areas);
5. Carry out a confirmatory geotechnical testing program to assess the material qualities of the existing pavement courses detailed in step 3;

6. Compile findings for existing pavement conditions and establish site specific pavement model;
7. Carry out a pavement analysis based on the traffic data provided for the study;
8. Develop cost-effective pavement rehabilitation alternatives based on results from steps 5, 6 and 7.

### **3.1 Review of roads construction history**

No data is available for review at the time of the preparation of the report.

### **3.2 Review of previous investigations**

No data is available for review at the time of the preparation of the report.

### **3.3 Visual Pavement Assessment**

A brief visual pavement condition survey has been carried out for this study on December 7, 2012. This work was carried out based on the MTO guidance for municipal roads (SP-022). The results of the visual assessment have identified the pavement distresses with their types, frequencies, and severities. A summary of the possible causes for the distresses are included in the assessment.

### **3.4 Confirmatory Pavement Borehole Investigation**

Prior to undertaking field drilling, clearance of existing utility services to the site was obtained from the applicable agencies. The field investigation was then undertaken on December 7, 2012 and comprised the drilling of 44 boreholes (30 in Winston Churchill Blvd and 14 in Olde Base Line Road) with 9 additional pavement cores (6 in Winston Churchill Blvd and 3 in Olde Base Line Road). The borehole depths varied from 1.5 to 5.0 m with shallower exceptions when bedrock was encountered. The borehole locations were selected by Coffey to maximize the coverage of the site.

All boreholes were drilled through the existing roadway pavement using a truck-mounted CME 75 drilling rig equipped with hollow/solid stem continuous flight auger equipment. The field drilling works were completed under the full time supervision of a Coffey Technician. Pavement granular samples were obtained directly off the retrieved augers. Subgrade soil samples were collected at regular intervals using a 50 mm (outside diameter) split-barrel sampler driven with a 63.5 kg hammer with a drop height of 0.76 m. Standard penetration testing (SPT) was conducted as per the procedures stipulated in ASTM D1586-11. All samples were logged in the field and returned to Coffey's laboratory in Etobicoke for review.

The exploratory borehole locations were not surveyed.

Borehole logs are presented with this report in **Appendix A**, with their respective locations presented on **Drawing 2**.

On completion of drilling, all boreholes were backfilled to the base of the asphalt pavement in accordance with the requirements of Ontario Regulation 903 and associated amendments. Each borehole was then covered with a single lift of nominally compacted, cold patch asphalt of a minimum thickness of 50 mm to match the surrounding pavement grade.

Groundwater level observations were made during drilling and in the open boreholes at the completion of the drilling operations. Details of groundwater observations for each borehole are presented on the respective borehole logs presented in **Appendix A**. No monitoring wells or piezometers were installed in the pavement boreholes during the investigation.

Further discussion on groundwater may be referred to the Preliminary Hydrogeological Study.

### 3.5 Geotechnical Confirmatory Testing

In situ Standard Penetration Tests (SPTs) were undertaken at frequent depth intervals using a 50 mm outside diameter and 35 mm internal diameter split barrel sampler driven with a hammer of mass 63.5 kg dropping 760 mm in accordance with the ASTM D 1586-11 test method – “The Standard Method of Standard Penetration Testing (SPT)”.

**Table 3.5.1 Summary of In-situ Testing Schedule**

Location	No of Boreholes	SPT Testing	
		In Granular	In Subgrade
Winston Churchill Blvd	30	2	4
Olde Base Line Road	14	3	3
<i>Total</i>	44	5	7

Selected soil samples were submitted to Coffey’s laboratory for natural moisture content determination, the results of which are presented on the borehole logs in **Appendix A**. Selected granular and subgrade soil samples taken from the boreholes were tested for grain size distribution determinations, the results of which are presented in **Appendix B**.

**Table 3.5.2 Summary of Laboratory Testing Schedule**

Location	No of Boreholes	Testing for Moisture Content		Testing for Grain Size Distribution	
		Granular	Subgrade	Granular	Subgrade
Winston Churchill Blvd	30	18	11	6	3

Olde Base Line Road	14	15	6	4	2
<i>Total</i>	44	33	17	10	5

## 4 PAVEMENT SURFACE AND SUBSURFACE CONDITIONS

### 4.1 Existing Pavement Conditions

#### 4.1.1 Summary of Pavement Assessment

The existing roadway sections of Winston Churchill Boulevard and Olde Base Line Road are both two lane rural constructions. A small creek tributary (identified as Erin Branch) meanders through from the north of the site. The pavement surface is generally constructed on low embankment, whilst in some areas the pavement surface being only slightly above the side ditches.

Faulty cross-fall was observed at several locations of the roads.

Rideability within the section is generally uncomfortable and fair at posted speed limits in Winston Churchill Boulevard and Olde Base Line, respectively.

Construction history of the roads, including recent rehabilitation or maintenance activities, was not known at the time of the investigation.

##### 4.1.1.1 Winston Churchill Blvd

The roadway sections lie in a generally flat area with a gentle down slope from north to south. The roadway section along Winston Churchill Blvd appears to be surfaced with a thin layer of asphalt surface course. The pavement condition is visually poor to very poor with intermittent medium severity ravelling, frequent medium severity single/multiple unsealed cracking, occasional high severity large area alligator cracking, and extensive medium severity pavement edge break. Deep seated pavement structural failures (deep ruts) were not frequent. A few to some localized depressions were observed where poor site drainage conditions were identified in the vicinities.

Evidence of multiple rehabilitation efforts was observed in many areas along the roadway.



**Figure 1 Winston Churchill Blvd. - General Pavement Overview, noting extensive edge repairs**



**Figure 2 Winston Churchill Blvd. - Close up on Pavement Surface Condition: Failing Patch Work, Severe Ravelling**



**Figure 3 Winston Churchill Blvd. - Pavement Edge Break/ Severe Cracking**



**Figure 4 Winston Churchill Blvd. - Surface Distortion (Wheel Path Rutting), and Flushing**



Largely, a 2.0 to 3.0 m wide unpaved shoulders flank each side of the road. The shoulders are generally surfaced with a layer of granular material consisting of sand and gravel. The overall condition of the shoulder is fair. No major deterioration was observed in the shoulder except occasional gullies on the outer shoulder which indicate the occurrence of minor soil erosion and some grass growth within the shoulder.

Side ditches are generally in need of major maintenance. In some areas, siltation and heavy vegetation were observed, which impede the performance of effective drainage conditions. Occasionally, faulty longitudinal or horizontal grading created a “bath tub” effect in the local areas.



**Figure 5 Winston Churchill Blvd. - Depress Areas near a Hydro Pole in Shoulder**



**Figure 6 Winston Churchill Blvd. - Ponding in Shoulder - Faulty Grading near Pavement Edge**

#### 4.1.1.2 Olde Base Line Road

The pavement condition along Olde Base Line Road is visually fair to poor with extensive sections of narrow shoulders. The pavement structure is constructed on near or at-grade with shallow side ditch flanking both sides of the road. The pavement distresses include frequent medium-severity cracking being observed throughout the project length. In isolated areas, it exhibits intermittent raveling and high-severity single and multiple cracking. Local depressions were observed elsewhere in the paved area.



**Figure 7 Olde Base Line - Typical Condition of Roadway**



**Figure 8 Olde Base Line - Multiple High Severity Longitudinal Cracks**

Largely, a 0.6 to 1.2 m wide unpaved shoulder flanks each side of the road. The shoulders are generally unpaved. The overall condition of the shoulder is poor to fair.

Roadside ditches of the roadway appeared to be partially functional. Tall grass overgrowth was observed in many sections of the drainage ditches.



**Figure 9 Olde Base Line - Very Narrow (or No) Shoulder, Tall Grass, Extensive Pavement Edge Cracking**

#### **4.1.2 Culvert (or Drainage) Survey**

Condition survey for cross road corrugated steel pipe culverts (CSP), if any, will be inspected and report submitted under a separate cover. It is expected that any existing CSP culvert will be replaced or modified where necessary during the new rehabilitation of the road.

#### **4.1.3 Possible Causes of Pavement Distresses**

The visual pavement condition survey indicated that the observed pavement varies significantly in performance at the site. Although the pavement history for construction, maintenance and rehabilitation is not known, it is our opinion, based on the visual evidences, that the pavement distresses for Winston Churchill may be associated with pavement structural deficiency, while Olde Base Line Road distresses may be a result of temperature related issues, lack of maintenance, problem associated with narrow (or nil) shoulders, or asphalt aging.

Site drainage on Winston Churchill Blvd is in need of upgrade, reinstatement and maintenance, i.e. clean up the sediment. Some evidence of frost heave is observed. Narrow shoulder configuration on Olde Base Line should be addressed as part of the current EA study.

## 4.2 Field Investigation Data and Laboratory Testing Results

The geology encountered across the site was as anticipated from review of the available OGS geological information. Borehole locations were selected in the driving lane or at edge of pavement along roadway sections, at approximately 200 m intervals alternating in opposite directions. Borehole locations in this report are referenced to metric chainages. The field layout was established by Coffey field staff based on the reference point stations painted on the edge of the highway pavement surface. The following table summarizes the borehole locations.

**Table 4.2.1 Summary of Borehole Locations**

BH No.	Winston Churchill Blvd.			BH NO.	Olde Base Line Road		
	Station	Southbound	Northbound		Station	Westbound	Eastbound
	0-050		<input checked="" type="checkbox"/>				
	0+000 (Olde Base Line intersection)				0+000 (Winston Churchill Blvd. Intersection)		
1	0+050		<input checked="" type="checkbox"/>	1	0+050		<input checked="" type="checkbox"/>
2	0+250	<input checked="" type="checkbox"/>		2	0+250	<input checked="" type="checkbox"/>	
3	0+450		<input checked="" type="checkbox"/>	3	0+450		<input checked="" type="checkbox"/>
4	0+650	<input checked="" type="checkbox"/>		4	0+650	<input checked="" type="checkbox"/>	
5	0+850		<input checked="" type="checkbox"/>	5	0+850		<input checked="" type="checkbox"/>
6	1+050	<input checked="" type="checkbox"/>		6	1+050	<input checked="" type="checkbox"/>	
7	1+250		<input checked="" type="checkbox"/>	7	1+250		<input checked="" type="checkbox"/>
8	1+450	<input checked="" type="checkbox"/>		8	1+450	<input checked="" type="checkbox"/>	
9	1+650		<input checked="" type="checkbox"/>	9	1+650		<input checked="" type="checkbox"/>
10	1+850	<input checked="" type="checkbox"/>		10	1+850	<input checked="" type="checkbox"/>	
11	2+050		<input checked="" type="checkbox"/>	11	2+050		<input checked="" type="checkbox"/>
12	2+250	<input checked="" type="checkbox"/>		12	2+250	<input checked="" type="checkbox"/>	
13	2+450		<input checked="" type="checkbox"/>	13	2+450		<input checked="" type="checkbox"/>
14	2+650	<input checked="" type="checkbox"/>		14	2+650	<input checked="" type="checkbox"/>	
15	2+850		<input checked="" type="checkbox"/>		2+700 (Mississauga Road Intersection)		
16	3+050	<input checked="" type="checkbox"/>					
17	3+250		<input checked="" type="checkbox"/>				
18	3+450	<input checked="" type="checkbox"/>					
19	3+650		<input checked="" type="checkbox"/>				
20	3+850	<input checked="" type="checkbox"/>					
21	4+050		<input checked="" type="checkbox"/>				
22	4+250	<input checked="" type="checkbox"/>					
23	4+450		<input checked="" type="checkbox"/>				
24	4+650	<input checked="" type="checkbox"/>					

BH No.	Winston Churchill Blvd.		BH NO.	Olde Base Line Road
25	4+790		<input checked="" type="checkbox"/>	
26	5+050	<input checked="" type="checkbox"/>		
27	5+250		<input checked="" type="checkbox"/>	
28	5+450	<input checked="" type="checkbox"/>		
29	5+650		<input checked="" type="checkbox"/>	
30	5+850	<input checked="" type="checkbox"/>		
	6+000 (Bush Street)			

Asphalt thickness measurement was taken in core holes at all borehole locations. Cores were taken at selected locations. Pavement Core Logs and Core Photographs are presented in **Appendix C**. No specified asphalt testing was commissioned for this assignment.

Generally, the pavement structure consisted of an asphaltic concrete with thickness varying significantly between 15 mm and 200 mm overlying a layer of granular base/sub-base material ranging in thickness from 130 mm to over 1.4 m.

A detailed description of the subsurface conditions encountered in the boreholes completed at the site is presented on the borehole logs in **Appendix A**. The generalized sub-surface conditions encountered are summarized as follows.

#### 4.2.1 Winston Churchill Boulevard

The existing pavement structure has been constructed to a two lane rural section; the roadway is supported on a low embankment constructed with fill, or on a native subgrade (including in places on inferred bedrock). The borehole data shows relative consistency in the character and condition of the subgrade soil (fill as well as native subgrade) along the length of the project, where the pavement profile is close to existing grade.

SPT “N” values in the near surface zone (upper 0.76 m below surface) of high blow counts were recorded. The high blow counts were likely a result of the frost in soil. Penetration index recorded at a depth of 0.76 m (or slightly below) recorded N values ranging from 8 to 26 blows/300 mm, indicating a loose to compact condition.

Field moisture content recorded in the granular base layer ranged from 2.2 to 4.0%. In BH10 (at Sta. 1+850), the recorded moisture content was 7.7%, indicating wetter than normal conditions.

Field moisture content recorded in the granular subbase layer ranged from 2.8 to 10.0%. However, in several borehole locations, wetter than normal conditions were found (BH 4 at Sta. 0+650, 21.1%; BH10, 13.1%; BH16 at 3+050, 16.6%; and BH23 at 4+450, 12.4%).

Bedrock was inferred at shallow depth, varying from 0.76 m to 5.0 m, in some boreholes.

Generally, subgrade soil encountered in the boreholes underlying the pavement structure comprised a layer of sandy silt to silty sand. This deposit generally includes a trace to some clay. The clay content is sufficient to impart a weak plasticity to the soil. Trace gravel was also encountered within the subgrade soil in many boreholes.

The native sandy silt till to silty sand till generally extended beyond the termination depth of the investigation except in the boreholes terminating on the inferred bedrock. Based on local experience and grain size distribution results, this silty sand to sandy silt till subgrade is considered low frost susceptible.

The natural moisture contents measured within the subgrade range from 7 (silty sand) to 38% (sandy silt with clay).

The auger holes were dry and open during the field work. No groundwater was encountered during drilling or on completion of the boreholes. Based on the geology encountered during the investigation, significant volumes of groundwater are not anticipated beneath the site, though the groundwater conditions encountered may vary due to temperature, season, precipitation and other factors that may differ from those experienced at the time of the investigation. Perched water conditions could also occur due to the accumulation of surface water within the pervious granular material overlying the relatively low pervious native till.

The encountered strata are presented on the attached Borehole Records in Appendix A of this report. The existing pavement cross-section consists of the following:

**Winston Churchill Blvd from Olde Base Line Rd northward to Bush St**

Station	Southbound					Northbound					Station
	Thickness (mm)					Thickness (mm)					
	Asph	Base	Sub Base	Total Gran	Type of Subgrade	Asph	Base	Sub Base	Total Gran	Type of Subgrade	
0-050						45	605	250	855	Cl Si Some Sa	0-050
0+050						40	280	Nil	280	Cl Si Some Sa	0+050
0+250	40	360	350	710	Bedrock						0+250
0+450						40	360	500	860	Sa Si	0+450
0+650	45	455	Nil	455	Cl Si Tr Sa						0+650
0+850						110	245	255	500	Si Sa	0+850
1+050	30	270	250	520	Si Cl Tr Sa						1+050
1+250						75	485	Nil	485	Cl Si	1+250
1+450	40	465	Nil	465	Si Sa Tr Gr						1+450
1+650						85	450	Nil	450	Si Sa Tr Gr	1+650
1+850	100	405	Nil	405	Sa Si Tr Cl (Till)						1+850
2+050						45	335	Nil	335	Si Sa Tr Gr	2+050
2+250	40	250	310	560	Sa Si Tr Cl						2+250
2+450						25	280	455	735	Cl Si	2+450
2+650	45	415	Nil	415	Sa Si						2+650
2+850						70	440	Nil	440	Cl Si Tr Sa	2+850
3+050	75	485	Nil	485	Sa Si						3+050
3+250						75	330	Nil	330	Sa Si Tr Cl	3+250
3+450	40	315	Nil	315	Si Sa Tr Gr						3+450
3+650						25	230	nil	230	Si Sa Some Gr	3+650
3+850	50	410	Nil	410	Si Sa Tr Gr						3+850
4+050						45	415	300	715	Cl Si Tr Sa	4+050
4+250	15	240	505	745	Si Sa Tr Gr						4+250
4+450						60	700	0	700	Si Sa Tr Cl	4+450
4+650	15	190	555	745	Bedrock						4+650
4+790						50	550	900	1450		4+790
5+050	100	305	355	660	Cl Si Tr Sa Tr Gr						5+050
5+250						100	510	890	1400		5+250
5+450	45	415	Nil	415	Si Sa Some Gr						5+450
5+650						80	530	890	1420		5+650
5+850	40	165	1295	1460							5+850
Averages	48	343	241.3	584.3		60.6	421.6	277.5	699.1		Averages
Minimum	15	165	0.0	315		25	230	0	230		Minimum
Maximum	100	485	1295	1460		110	700	900	1450		Maximum
	15	15	15	15		16	16	16	16		

The following charts illustrate the thickness distributions for each pavement layer component along Winston Churchill Blvd.



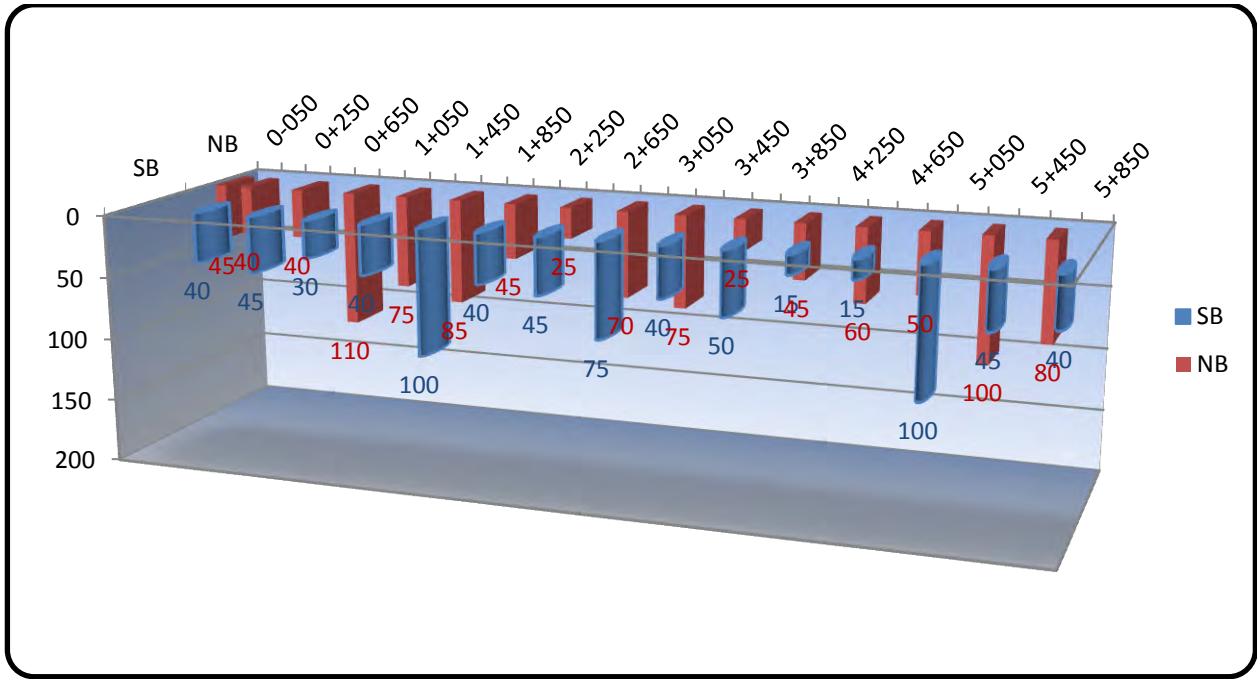


Figure 10 Winston Churchill Blvd Asphalt Concrete Layer Thickness Distribution

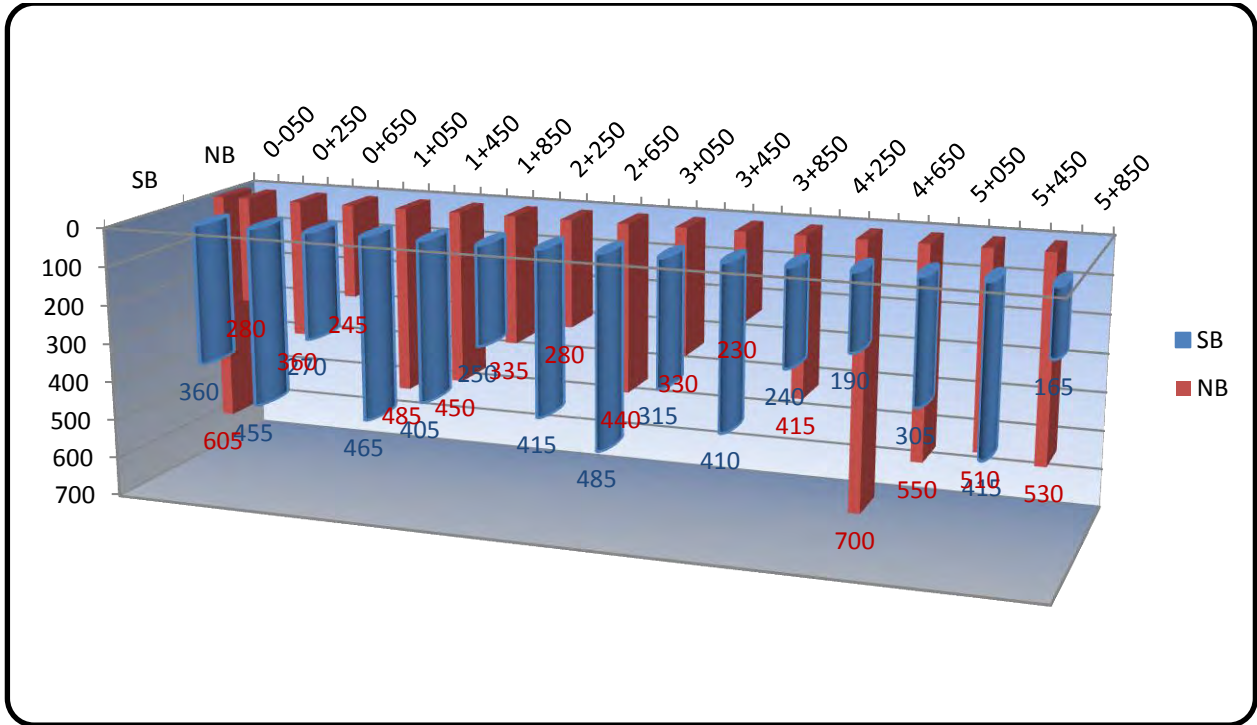
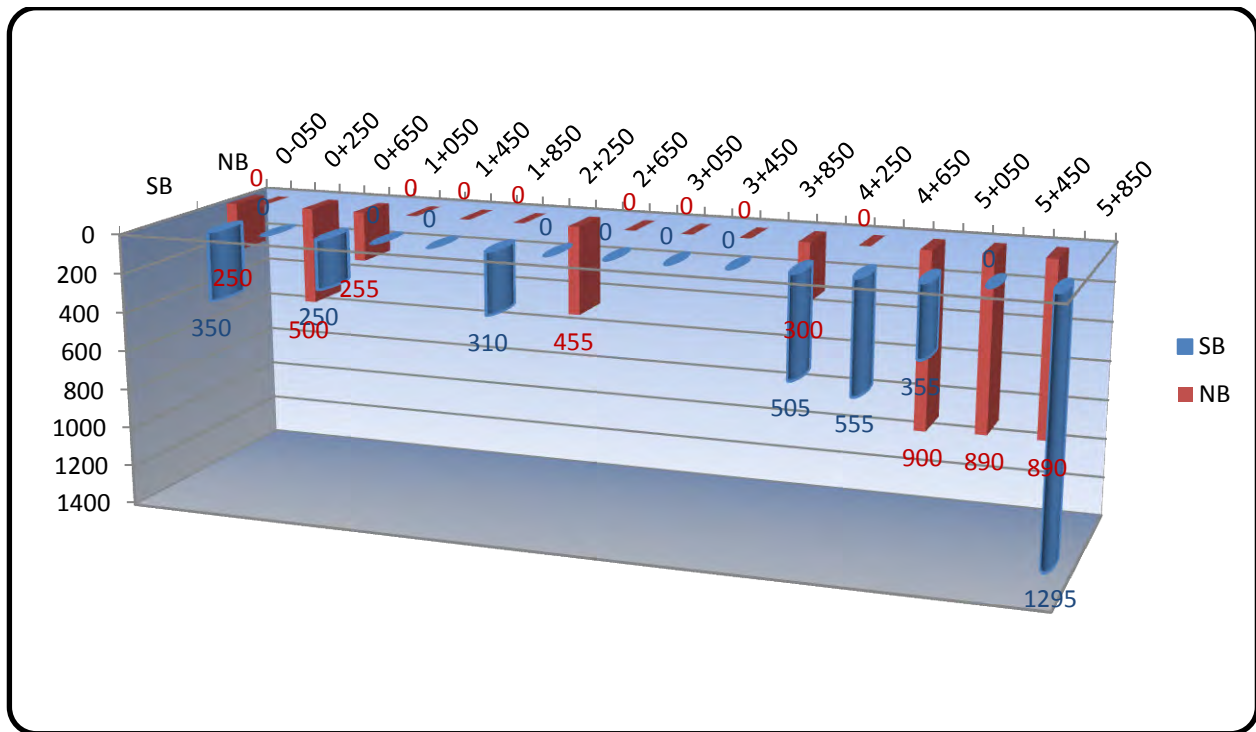
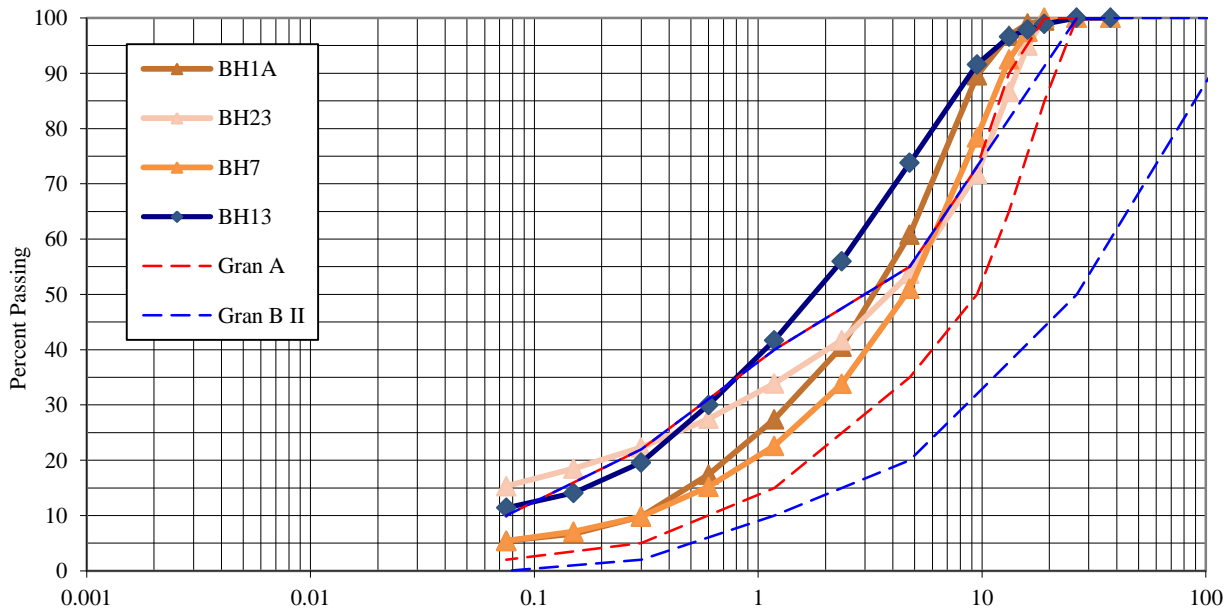


Figure 11 Winston Churchill Blvd Granular Base Thickness Distribution



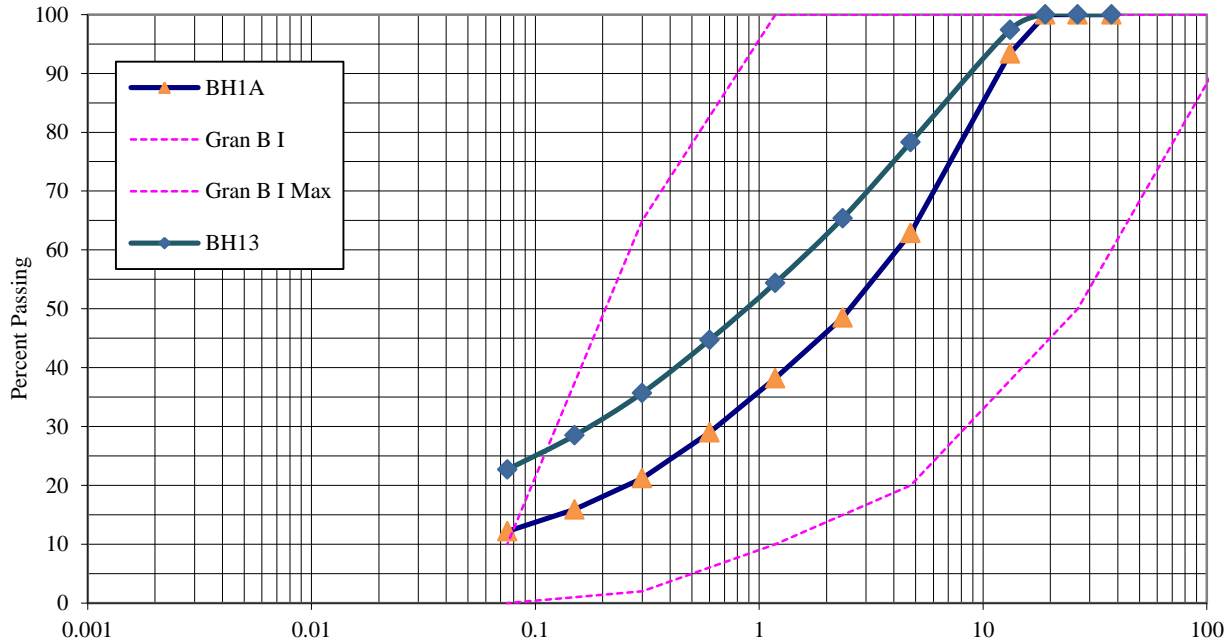
**Figure 12 Winston Churchill Blvd Granular SubBase Thickness Distribution**

Laboratory testing results show that the granular base samples may exceed or be on the fine side in comparison with the gradation specifications of a OPSS Granular A material.



**Figure 13 Winston Churchill Blvd. Laboratory Testing Results (Particle Size Distribution) of the Granular Base Material**

It is important to realize, although a standard practice, that the split spoon sampler has a size limitation for the samples which can be taken from the ground. Auger samples tend to represent a mixture of multiple soil layers. The gradation distributions of granular layers may be adversely affected by the grinding action during the sampling process, and also cannot be accurately estimated based on the small samples taken from the borehole investigation.



**Figure 14 Winston Churchill Blvd. Laboratory Testing Results (Particle Size Distribution) of the Granular SubBase Material**

#### 4.2.2 Olde Base Line Road

The existing pavement structure on Olde Base Line Road has been constructed to a two lane rural section; the roadway is supported on a low embankment constructed with fill, or on a native subgrade (including in places on inferred bedrock). The borehole data show relative consistency in the character and condition of the subgrade soil (fill as well as native subgrade) along the length of the project, where the pavement profile is close to existing grade.

Penetration index recorded at a depth of 0.76 m (or slightly below) recorded N values ranging from 3 to 29 blows/300 mm, indicating a very loose to compact condition (or soft to very stiff). Peat was observed in Boreholes BH1 and BH2.

Field moisture content recorded in the granular base layer ranged from 2.9 to 5.3%.

Field moisture content recorded in the granular subbase layer ranged from 5.0 to 8.6%. However, in several borehole locations, wetter than normal conditions were found (BH 7 at Sta. 1+250, 17.8%; BH8 at 1+450, 23.4%; BH9 at 1+650, 18.5%; and BH13 at 2+450, 20.4%). The road sections with wet subbase conditions exhibited extensive pavement cracks, as shown in Figure 8 of Section 4 of the report.

Generally, subgrade soil encountered in the boreholes underlying the pavement structure comprised a layer of clayey silt to silty sand. This deposit generally includes a trace of to some clay. The clay content is sufficient to impart a weak plasticity to the soil. A trace of gravel was also encountered within the subgrade soil in many boreholes.

The natural moisture contents measured within the subgrade range from 4.5 (sand) to 23% (clayey silt, some sand).

The native soil generally extended beyond the termination depth of the investigation except in the boreholes terminating on the inferred bedrock.

Based on local experience and grain size distribution testing results, the silty sand till subgrade is considered low to medium frost susceptible.

Bedrock was inferred at shallow depth, varying from 1.1 m to 3.5 m, in some boreholes.

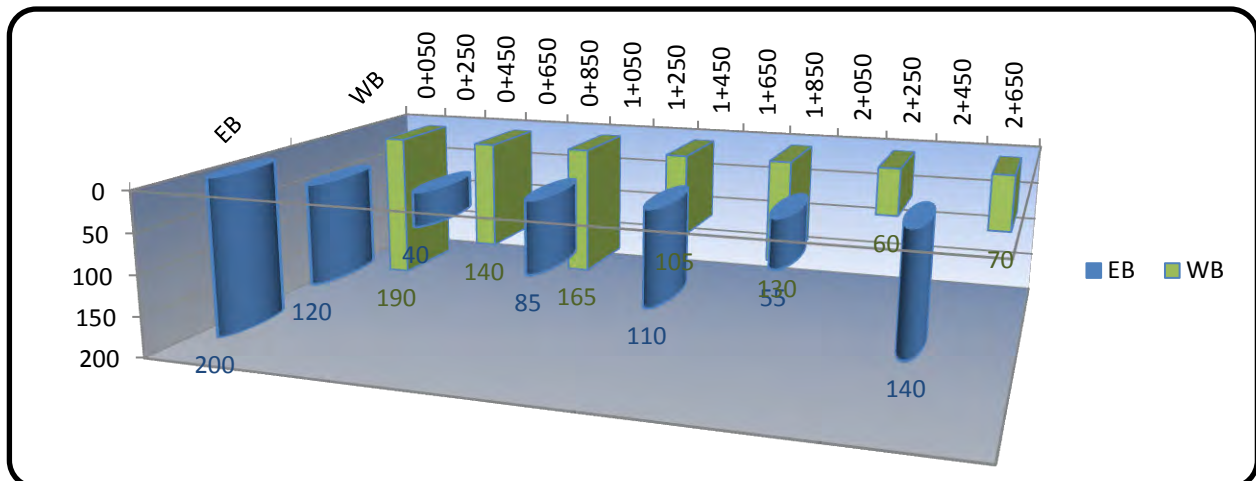
The auger holes were dry and open during the field work. No groundwater was encountered during drilling or on completion of the boreholes. Based on the geology encountered during the investigation, significant volumes of groundwater are not anticipated beneath the site, though the groundwater conditions encountered may vary due to temperature, season, precipitation and other factors that may differ from those experienced at the time of the investigation. Perched water conditions could also occur due to the accumulation of surface water within the pervious granular material overlying the relatively low pervious native till.

The encountered strata are presented on the attached Borehole Records in Appendix A of this report. The existing pavement cross-section consists of the following:

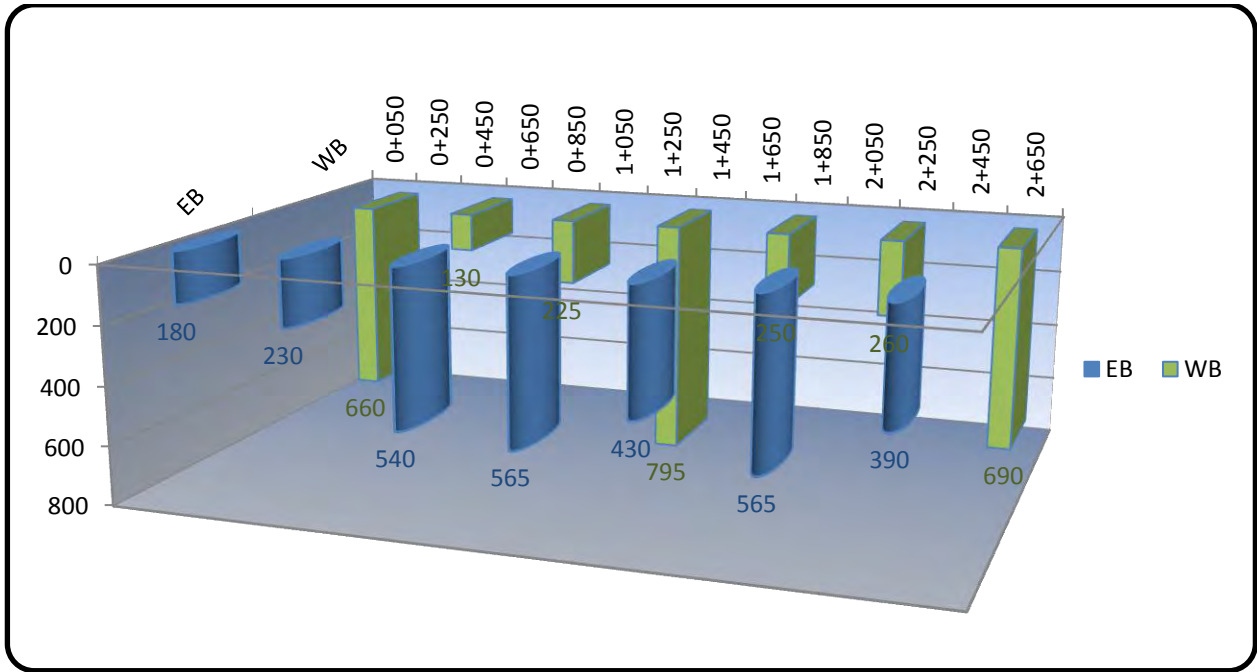
**Olde Base Line Rd from Winston Churchill Blvd eastward to Mississauga Rd**

Station	Westbound					Eastbound					Station
	Thickness (mm)					Thickness (mm)					
	Asph	Base	Sub Base	Total Gran	Type of Subgrade	Asph	Base	Sub Base	Total Gran	Type of Subgrade	
0+050						200	180	Nil	180	Si Sa Some Gr	0+050
0+250	190	660	Nil	660	Cl Si Some Sa						0+250
0+450						120	230	850	1080	Bedrock	0+450
0+650	140	130	Nil	130	Si Sa Some Gr						0+650
0+850						40	540	920	1460		0+850
1+050	165	225	Nil	225	Si Sa Some Gr						1+050
1+250						85	565	Nil	565	Cl Si	1+250
1+450	105	795	Nil	795	Cl Si Some Sa						1+450
1+650						110	430	Nil	430	Cl Si	1+650
1+850	130	250	Nil	250	Sa Si Some Gr						1+850
2+050						55	565	480	1045	Bedrock	2+050
2+250	60	260	1180	1440							2+250
2+450						140	390	Nil	390	Cl Si	2+450
2+650	70	690	nil	690	Si Sa Some Gr						2+650

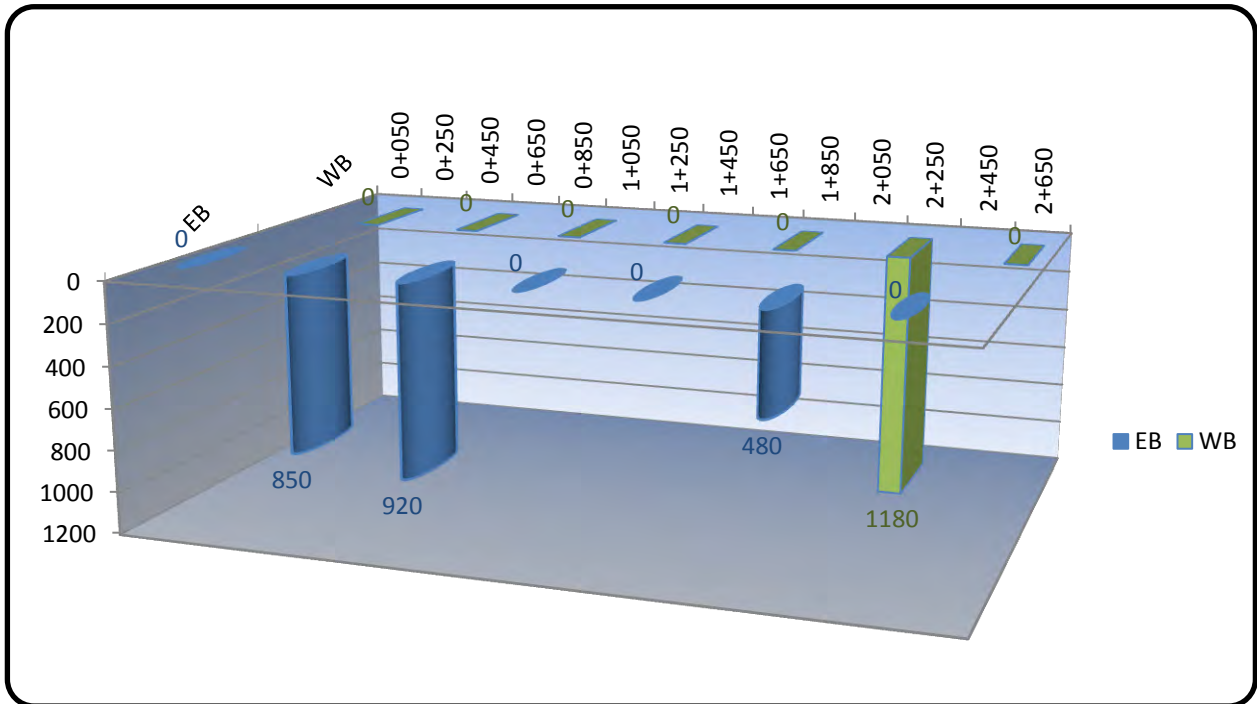
The following charts illustrate the thickness distributions for each pavement layer component along Olde Base Line Road.



**Figure 15 Olde Base Line Rd Asphalt Concrete Thickness Distribution**

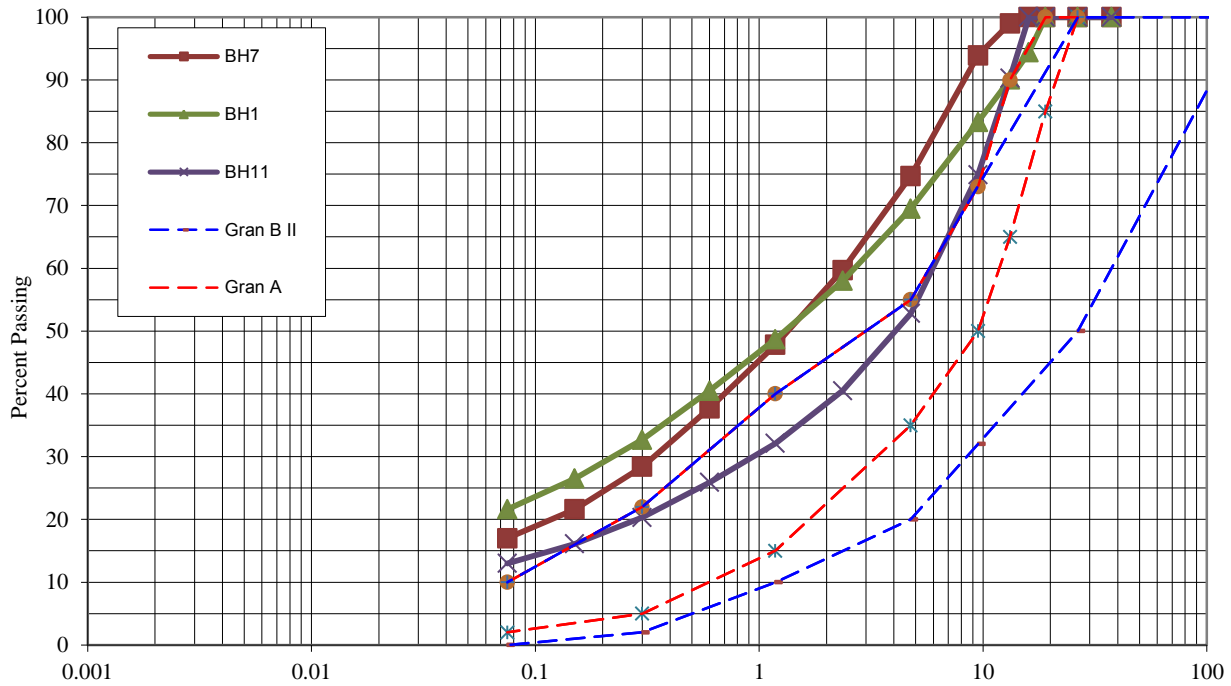


**Figure 16 Olde Base Line Rd. Granular Base Thickness Distribution**

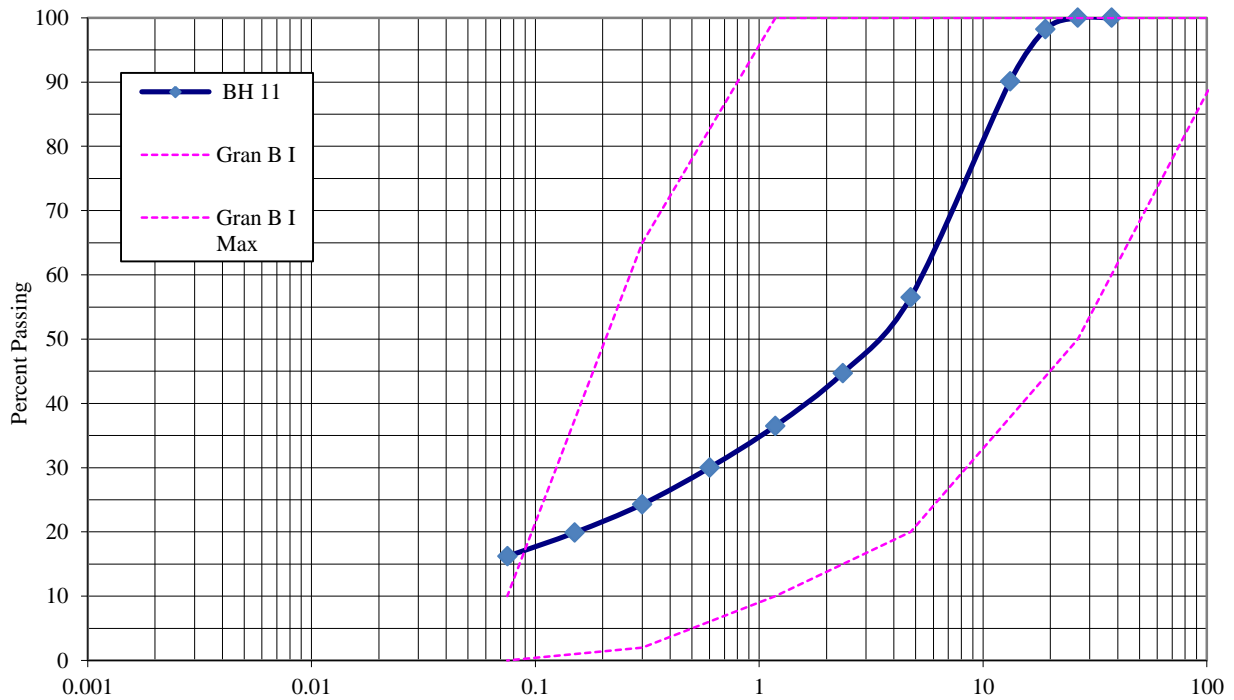


**Figure 17 Olde Base Line Rd. Granular SubBase Thickness Distribution**

Laboratory testing results show that the granular base samples may exceed or be on the fine side in comparison with the gradation specifications of a OPSS Granular A material.



**Figure 18 Olde Base Line Road Laboratory Testing Results (Particle Size Distribution) of the Granular Base Material**



**Figure 19 Olde Base Line Road Laboratory Testing Results (Particle Size Distribution) of the Granular SubBase Material**

It is important to realize, although a standard practice, that the split spoon sampler has a size limitation for the samples which can be taken from the ground. Auger samples tend to represent a mixture of multiple soil layers. The gradation distributions of granular layers may be adversely affected by the grinding action during the sampling process, and also cannot be accurately estimated based on the small samples taken from the borehole investigation.

### 4.3 Pavement Structural Deficiency Analyses

It is understood that the current assignment includes a preliminary analysis for existing pavement condition and performance of the existing roadways. This exercise focuses on the “current” pavement conditions of the study roads and their potential “near term” and long term performance. The results of the exercise will be utilized to assist the client to develop strategic decisions of pavement improvement for the study corridor.

#### 4.3.1 Input Parameters for Analysis of Existing Condition

From a pavement structural strength viewpoint, the condition of the granular components has in all likelihood, deteriorated in the period since construction, resulting in reduction in grain size which may take some of the existing granular materials outside current OPSS specifications for gradation. Pavement structural layer strength reduction will be required due to deteriorated granular material and existing distress for analysis purposes.

For preliminary analyses, the MTO recommended factors on Granular Base Equivalency (GBE) methodology<sup>1</sup> is used. The GBE analysis methodology does not require a design life as input parameter. The following GBE layer reduction coefficients are adopted for the evaluation of existing pavement structural capacity (deficiency).

Material	GBE Factor
Resurfacing - Cold in Place mix with New Granular A	1.0
Resurfacing – Pulverized Asphalt mixed with Existing Base	1.0
Resurfacing - Old Granular Base	0.75
Resurfacing - Old Granular Subbase	0.5
Reconstruction – Old Granular Base	0.6
Reconstruction – Old Granular Subbase	0.4

For comparison, pavement structural analyses for existing pavement condition are carried out based on the 1993 ‘AASHTO Guide for the Design of Pavement Structures’ and the Ontario Ministry MI-183 publication ‘Adaption and Verification of the AASHTO Pavement Design for Ontario Conditions’ (dated March 9, 2001,

---

<sup>1</sup> Page 154 Table 3.5 Granular Base Equivalency Factors, Pavement Design and Rehabilitation Manual, published by Ontario Ministry of Transportation, dated 1990



plus Addendum dated December 2011). The pavement analyses have been prepared assuming a 20 year design life.

Route	Initial/Terminal Serviceability	Cumulative ESALs (initial design life)	Design Subgrade Resilient Modulus ( $M_R$ )
<b>Pavement Resurfacing /Rehabilitation</b>			
Winston Churchill Blvd	$p_i = 4.2, p_t = 2.0$	420,800 (20 years)	25
Olde Base Line Road	$p_i = 4.2, p_t = 2.0$	500,800 (20 years)	25
<u>Structural Coefficients ('a' values):</u>			
New HMA	: 0.42		
New Base (Gran A)	: 0.14		
New Subbase (Gran B-III)	: 0.09		
Old HMA	: 0.27 (for final resurfacing)		
	: 0.24 (for checking the adequacy of milled surface)		
Old Granular Base	: 0.12		
Old Granular Subbase	: 0.07		
<u>Drainage Coefficient</u>	:		
	m = 1.0 (for new granular base);		
	m = 0.9 (for existing /old base and subbase)		
<u>Standard Deviation</u>	: S = 0.44		
<u>Reliability</u>	: R = 85%		

The pavement structural number (SN) required for supporting the predicted traffic conditions, based on the above input data, for Winston Churchill Blvd and Olde Baseline is 91 and 84, respectively.

In comparison, the following illustrations describe the pavement structural competency (deficiency) based on the material quality(ies), the structural layer thicknesses and projected future traffic for a similar road condition in Peel Region. For reference, a typical municipal structural standard is also included for comparison.

**Winston Churchill Blvd**

	Municipal Typical	Southbound	Northbound
<b>Section 1 (Sta. 0+000 to Sta. 2+150)</b>			
Asphalt Concrete (mm)	100 mm Asphalt	30 – 100 mm Asphalt (average 51 mm)	40 – 110 mm Asphalt (average 63 mm)
Granular Base	150 mm Gran Base (OPSS Gran. A)	270 – 465 mm Gran Base (average 391 mm)	245 – 605 mm Gran Base (average 394 mm)
Granular Subbase	300 mm Gran Subbase (OPSS Gran. B)	0 – 350 mm Gran Subbase (average 120 mm)	0 – 500 mm Gran Subbase (average 144 mm)
Subgrade	Subgrade	Subgrade (Variable)	Subgrade (Si Sa to Cl Si)
GBE	550	417	446
SNeq	90	64	69
<b>Section 2 (Sta. 2+150 to Sta. 3+350)</b>			
Asphalt Concrete (mm)	100 mm Asphalt	40 – 75 mm Asphalt (average 53 mm)	25 – 75 mm Asphalt (average 57 mm)
Granular Base	150 mm Gran Base (OPSS Gran. A)	250 – 485 mm Gran Base (average 383 mm)	280 – 440 mm Gran Base (average 350 mm)
Granular Subbase	300 mm Gran Subbase (OPSS Gran. B)	0 – 310 mm Gran Subbase (average 103 mm)	0 – 455 mm Gran Subbase (average 152 mm)
Subgrade	Subgrade	Subgrade (Sa Si)	Subgrade (Sa Si to Cl Si)
GBE	550	405	410
SNeq	90	63	63
<b>Section 3 (Sta. 3+350 to Sta. 3+950)</b>			
Asphalt Concrete (mm)	100 mm Asphalt	40 – 50 mm Asphalt (average 45 mm)	25 mm Asphalt (average 25 mm)
Granular Base	150 mm Gran Base (OPSS Gran. A)	315 – 410 mm Gran Base (average 363 mm)	230 mm Gran Base (average 230 mm)
Granular Subbase	300 mm Gran Subbase (OPSS Gran. B)	0 – 0 mm Gran Subbase (average 0 mm)	0 mm Gran Subbase (average 0 mm)
Subgrade	Subgrade	Subgrade (Si Sa)	Subgrade (Si Sa)
GBE	550	329	204
SNeq	90	52	32
<b>Section 4 (Sta. 3+950 to Sta. 4+750)</b>			
Asphalt Concrete (mm)	100 mm Asphalt	15 mm Asphalt (average 15 mm)	45 - 60 mm Asphalt (average 53 mm)
Granular Base	150 mm Gran Base (OPSS Gran. A)	190 – 240 mm Gran Base (average 215 mm)	415 - 700 mm Gran Base (average 558 mm)
Granular Subbase	300 mm Gran Subbase (OPSS Gran. B)	505 – 555 mm Gran Subbase (average 530 mm)	0 – 300 mm Gran Subbase (average 150 mm)
Subgrade	Subgrade	Subgrade	Subgrade
GBE	550	445	560
SNeq	90	61	86
<b>Section 5 (Sta. 4+750 to Sta. 5+550)</b>			
Asphalt Concrete (mm)	100 mm Asphalt	15 - 100 mm Asphalt (average 53 mm)	50 - 100 mm Asphalt (average 75 mm)
Granular Base	150 mm Gran Base (OPSS Gran. A)	190 – 415 mm Gran Base (average 303 mm)	510 - 550 mm Gran Base (average 530 mm)

	Municipal Typical	Southbound	Northbound
Granular Subbase	300 mm Gran Subbase (OPSS Gran. B)	0 – 555 mm Gran Subbase (average 303 mm)	890 – 900 mm Gran Subbase (average 895 mm)
Subgrade	Subgrade	Subgrade	Subgrade
GBE	550	445	939
SNeq	90	67	135
<b>Section 6 (Sta. 5+550 to Sta. 5+750)</b>			
Asphalt Concrete (mm)	100 mm Asphalt	No Data	80 mm Asphalt (average 80 mm)
Granular Base	150 mm Gran Base (OPSS Gran. A)		530 mm Gran Base (average 530 mm)
Granular Subbase	300 mm Gran Subbase (OPSS Gran. B)		890 mm Gran Subbase (average 890 mm)
Subgrade	Subgrade		Subgrade
GBE	550		943
SNeq	90		136
<b>Section 7 (Sta. 5+750 to Sta. 6+000)</b>			
Asphalt Concrete (mm)	100 mm Asphalt	40 mm Asphalt (average 40 mm)	No Data
Granular Base	150 mm Gran Base (OPSS Gran. A)	165 mm Gran Base (average 165 mm)	
Granular Subbase	300 mm Gran Subbase (OPSS Gran. B)	1295 mm Gran Subbase (average 1295 mm)	
Subgrade	Subgrade	Subgrade	
GBE	550	821	
SNeq	90	111	
<b>Olde Base Line Road (Sta. 0+000 to Sta. 2+700)</b>			
	Municipal Typical	Southbound	Northbound
Asphalt Concrete (mm)	100 mm Asphalt	60 – 190 mm Asphalt (average 123 mm)	40 – 200 mm Asphalt (average 107 mm)
Granular Base	150 mm Gran Base (OPSS Gran. A)	130 – 795 mm Gran Base (average 430 mm)	180 – 565 mm Gran Base (average 414 mm)
Granular Subbase	300 mm Gran Subbase (OPSS Gran. B)	0 – 1180 mm Gran Subbase (average 169 mm)	0 – 920 mm Gran Subbase (average 321 mm)
Subgrade	Subgrade	Subgrade (Cl Si to Si Sa to Sa Si)	Subgrade (Si Sa to Cl Si to Bedrock)
GBE	550	561	604
SNeq	90	92	94

If the future traffic is to include trucks and buses or there is a significant increase in the traffic volume, the pavement may need to be fully upgraded to support the proposed traffic conditions.

In general, the structurally deficient sections correspond to the visual distress indicators.

Through the review of the field investigation, laboratory testing data and pavement structural analyses, it appears that the main causes of the distresses in the subject roadway sections are largely attributed to insufficient strength and stability (Winston Churchill Blvd.) and temperature related deteriorations (Olde Base Line Road). For both roads, some common problems are also identified, including the pavement aging related poor surfacing, water logging due to top permeable layers and bottom relatively impermeable layers, and possible untimely maintenance.

## 5 PRELIMINARY PAVEMENT REHABILITATION STRATEGY

### 5.1 Traffic Data

The following traffic data was provided by the client for the current study:

	Winston Churchill Boulevard	Olde Base Line Road
Count Year	2012	2012
AADT (2011)	2147	2230
Annual growth factor	2% assumed	2% assumed
Commercial Vehicle Ratio (maximum)	6%	3%

### 5.2 Design Criteria and Primary Considerations

It is understood that the Regional Municipality of Peel is considering upgrading the roadways as part of the corridor improvements. It is assumed that the roadway profile will remain similar to the existing. At the time of the preparation of the report, no widening of the pavement platform is required. No plans for upgrade of the intersections, side roads or associated side entrances are considered.

Side ditches and drainage design is beyond the scope of this study.

The recommended pavement thickness designs for the project are based on the 1993 'AASHTO Guide for the Design of Pavement Structures' and the Ontario Ministry MI-183 publication 'Adaption and Verification of the AASHTO Pavement Design for Ontario Conditions' (dated March 9, 2001, plus Addendum dated December 2011). The pavement thickness designs have been prepared on the basis of a 20 year design life.

In Section 4, it is noted that the thickness of the granular pavement components varies significantly at the locations of the boreholes. There was no apparent intermixing between the granular base/subbase and the underlying subgrade at the borehole locations, which indicates no apparent rutting in the subgrade. This indicates that the overall pavement structural layer thicknesses in general are sufficient to support the "current" traffic conditions. However, based on the visual examination and limited laboratory testing results, the condition of the granular components has deteriorated in the period since construction, resulting in reduction in grain size which may take some of the existing granular materials outside current OPSS specifications for gradation. These may be replaced with new granular materials which conform to the OPSS specifications.

The recommendations for pavement design provided in Table 5.1 below are for preliminary consideration to assist 30% detail design for the Class EA, and are based on the "projected" traffic volume and the sub-grade soil properties identified during the ground investigation.

Final considerations on rehabilitation alternatives, discussions on material reuse, life cycle analysis and incorporating other design features can be developed in accordance with the project design standards. As such, the recommendations provided in this report should be considered a minimum requirement and for preliminary design purposes only.

## 5.2.1 Winston Churchill Blvd

### 5.2.1.1 Review of the alternatives

The asphalt concrete courses on Winston Churchill Blvd are generally thin. Granular base and subbase material gradings do not generally conform to the relevant OPSS requirements. Based on the field observations and the analysis, the inspected pavement condition of Winston Churchill Blvd is considered to be close to its terminal condition. As discussed above, the asphalt thicknesses are grossly inadequate when compared to contemporary GTA municipality requirements for similar roads.

We have carried out a breakdown analysis based on the HDR/Region's request in order to explore alternatives as shown in the table below. However, the analysis is based on the structural strength only. The analysis does not address drainage issues, nor does it consider the profile continuity which is a decision to be undertaken by the Region during the detailed design stage.

**Table 5.1: Pavement Design Considerations**

Subsection		Minimum Requirement Based on the Structural Strength	Minimum Required Pavement Make-up Average Thickness (mm)		
			AC	Gran. A (Old)	Gran. B (Old)
1	from Old Base Line (0+000) to Sta. 2+200	AC Replacement: 1) remove AC 2) compact existing Gran. Base 3) Place new AC 110 mm resulting in an average grade raise of 55 mm.	110 (40mm HL-3 and 70mm HL-8)	390	130
2	2+200 to 3+350	AC Replacement: 1) remove AC 2) compact existing Gran. Base 3) Place new AC 100 mm resulting in an average grade raise of 45 mm.	100 (40mm HL-3 and 60mm HL-8)	365	125
3	3+350 to 4+050	Full Depth Pavement Reconstruction: 1) excavate 360 mm below the existing pavement 2) place 300 mm new Gran. A 3) Place new AC 110 mm resulting in an average grade raise of 55 mm.	110 (40mm HL-3 and 70mm HL-8)	300* <b>(new)</b>	0
4	4+050 to 4+750	AC Replacement: 1) remove AC 2) compact existing Gran. Base 3) Place new AC 100 mm resulting in an average grade raise of 65 mm.	100 (40mm HL-3 and 60mm HL-8)	385	340
5	4+750 to	AC Replacement: 1) remove AC 2) compact existing Gran. Base 3) Place new AC 100 mm	100 (40mm HL-3	415	600

Subsection	Minimum Requirement Based on the Structural Strength	Minimum Required Pavement Make-up Average Thickness (mm)			
		AC	Gran. A (Old)	Gran. B (Old)	
	5+550	resulting in an average grade raise of 35 mm.	and 60mm HL-8)		
6	5+550 to 5+750	Non Structural Overlay (mill 40 mm pave 40 mm)	80 (Mill 40mm pave 40mm HL-3)	530	890
7	5+750 to Bush intersection	AC Replacement: 1) remove AC 2) compact existing Gran. Base 3) Place new AC 50 mm resulting in an average grade raise of 10 mm.	50 (50mm HL-3)	165	1295

\* New Gran. A

Based on the pavement investigation and analysis, we have reviewed the following pavement rehabilitation alternatives:

1. Full Depth Pavement Reconstruction (mandatory for Subsection 3, optional for other Subsections): this alternative will address pavement structural deficiency, and it will correct wet base or subbase conditions.
2. AC Replacement (recommended for Subsections 1, 2, 4, 5 and 7; insufficient for Subsection 3; optional for Subsections 6): this alternative will address pavement structural deficiency and it does not remove existing base/subbase courses, but it will not correct wet base or subbase conditions.
3. Cold-in-place Recycling (CIR): this alternative will improve pavement structural capacity, but it cannot correct wet base or subbase conditions. Limitations: CIR usually works with where existing AC thickness exceeds 100 mm (or a minimum of 50mm). On Winston Churchill Blvd, the existing pavement AC thickness is too thin to work with.
4. Non Structural Overlay (recommended for Subsections 6; insufficient for other Subsections): this alternative will NOT improve pavement structural capacity, nor can it correct wet base or subbase conditions.

### 5.2.1.2 Recommendations

For preliminary design purposes, we recommend that a Full Depth AC replacement for all Subsections except a Full Depth Pavement Reconstruction for Subsection 3 should be implemented for Winston Churchill Blvd. Other factors (e.g. aging, temperature, drainage, maintenance, etc.) should also be considered during the detailed design stage where the final pavement rehabilitation methodology could change from our current recommendations.

### 5.2.2 Olde Base Line Road

For similar traffic and geological conditions, Olde Base Line road has performed relatively better. From a structural standpoint, the existing roadway pavement thickness at Olde Base Line road is in a much better condition. The roadway can be rehabilitated with a non structural overlay strategy (mill 50 mm pave 50 mm) for the future 20 year traffic.

Regular maintenance program, e.g. crack sealing, should be allowed and recommended immediately when it is found, throughout the life span of the pavement.

**Table 5.3: Final Pavement Make-up (Pavement Structure)**

Subsection		New Pavement Structure Average Thickness (mm)		
		AC	Gran. A (Old)	Gran. B (Old)
1	from WCB (0+000) to Sta. 2+700	115 (Mill 50mm pave 50mm HL-3)	422	245

### 5.3 Other Considerations

Insufficient drainage attributes to some significant pavement failures as identified through the investigation. A roadside drainage improvement program will be necessary to improve the current drainage conditions, which may include shoulder widening, ditch cleansing, sedimentation removal, cross-fall correction and ditch gradient correction and other appropriate measures.

Material specifications and construction considerations are beyond the scope of work for a preliminary pavement investigation. Pavement life cycle analysis can be addressed as part of the detailed design.

Based on available soil data, the recommended slope for pavement embankment could be 2 : 1 for preliminary design purpose. During detailed design stage, slope stability analysis shall be performed to adopt any changes in the above-recommended slope, if warranted.

Intersection improvements, side roads and entrances, and associated infrastructure improvements are not included in this study. Supplementary investigations will be required if concerns may arise during planning and design stages. As a general rule, the existing bituminous surface treatment/asphaltic concrete surfacing at intersections may be removed to the end of the proposed turn radii prior to constructing the new pavement, if applicable. Paving limits extending into the side roads may be required to match the finished grade and the corresponding HMA thicknesses where these sections lie adjacent to existing roadway. Butt (lap) joints may be constructed at the paving terminus of the project. The construction of the joints may be carried out in conformance with OPSS 310 requirements.

Commercial and residential entrances may be constructed in accordance with OPSD 301 series.

Culvert replacement and urban sections, if considered, will need additional investigations.

## 6 LIMITATIONS OF REPORT

Coffey should be retained for general review of the final design, grading plan and specifications to verify that this report has been properly interpreted and implemented. If not accorded the privilege of making this review, Coffey will assume no responsibility for interpretation of the recommendations in the report.

Coffey has endeavoured to assess all information provided to them during this investigation, but makes no guarantees or warranties as to the accuracy or completeness of this information. Any changes in the scope of the proposed Municipal Service Improvement works for this project may require the reassessment of ground conditions depending on the nature of any such future changes.

Sub-surface conditions can vary over relatively short distances and, as such, the ground conditions encountered by this investigation may not be fully representative of sub-surface conditions at all locations within the site. Therefore, we recommend that a geotechnical engineer be engaged during construction to confirm that the subsurface conditions are consistent with the design assumptions.

The comments given in this report are intended only for the guidance of design engineers. Contractors bidding on or undertaking the work should, in this light, decide on their own investigations, as well as their own interpretations of the factual borehole results, so that they may draw their own conclusions as to how the subsurface conditions may affect them.

The site investigation and recommendations follow generally accepted practice for Geotechnical Consultants in Ontario. Geotechnical laboratory testing has been completed in accordance with ASTM or CSA Standards or modifications of these standards that have become standard practice.

Further details of the limitations of this report are presented as **Appendix C**, "*Important Information about your Coffey Report*".



## 7 CLOSURE

We trust that the information contained in this report is satisfactory for your present needs. It is recommended that Coffey be retained for a general review of the final design, grading plan and overall specifications to verify that the findings and recommendations provided by this report have been properly interpreted and appropriately implemented.


Should you have any questions, please do not hesitate to contact the undersigned.

For and on behalf of Coffey

**Prem Chand, P.Eng.**  
Pavement Engineer

  
**Mani Patchayappan, EIT**  
Geotechnical Consultant

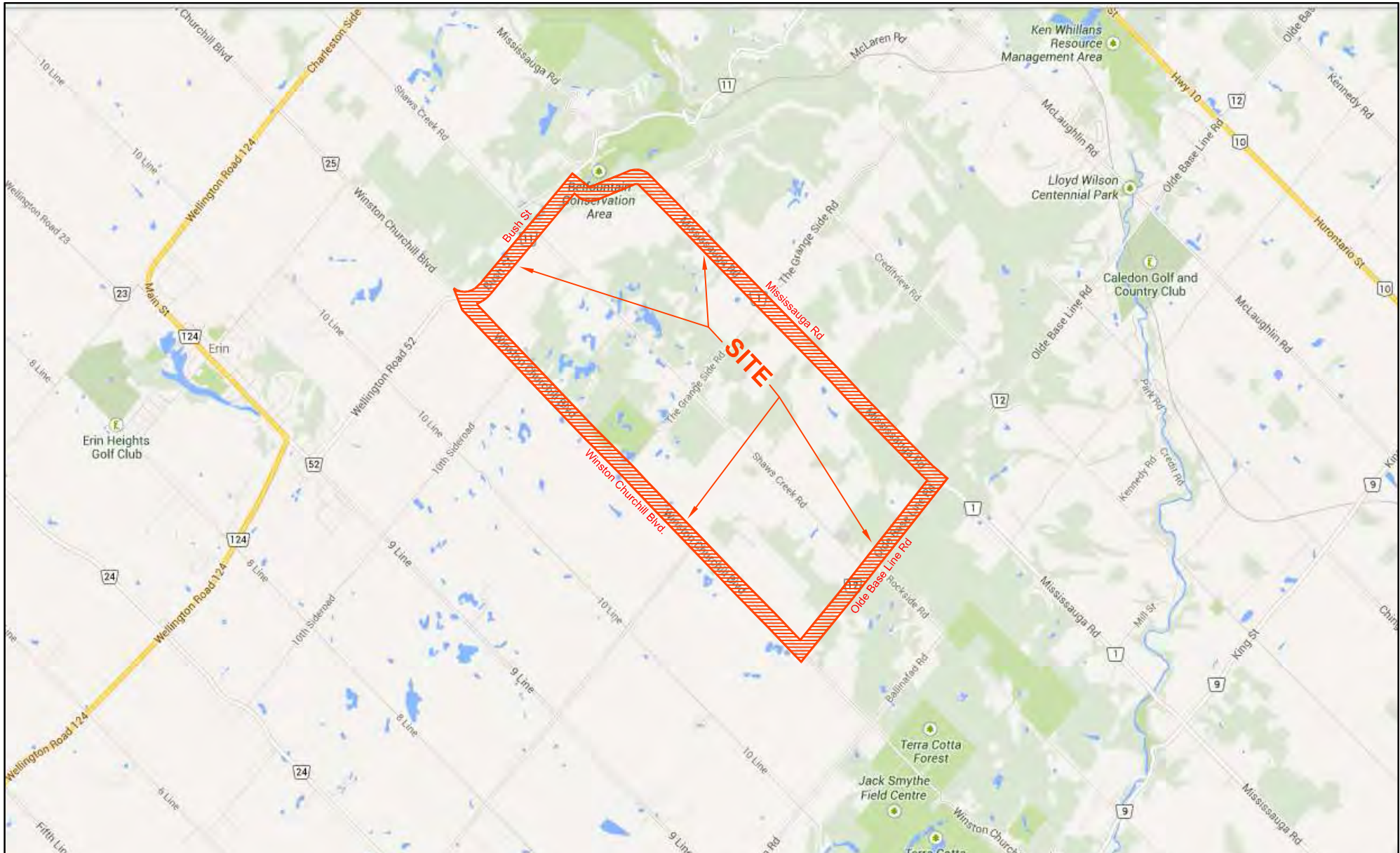
  
**Vasantha Wijeyakulasuriya, P.Eng**  
Senior Principal

  
**Bill Feng, P.Eng.**  
Associate Geotechnical Engineer



Geotechnical Investigation Report Improvements to  
Regional Road Corridor Bounded by Winston Churchill Blvd., Bush St., Old Main St., Mississauga Rd., Olde Base Line Rd.  
Wellington, Ontario  
Regional Municipality of Peel  
Peel Project 11-4360

# Drawings

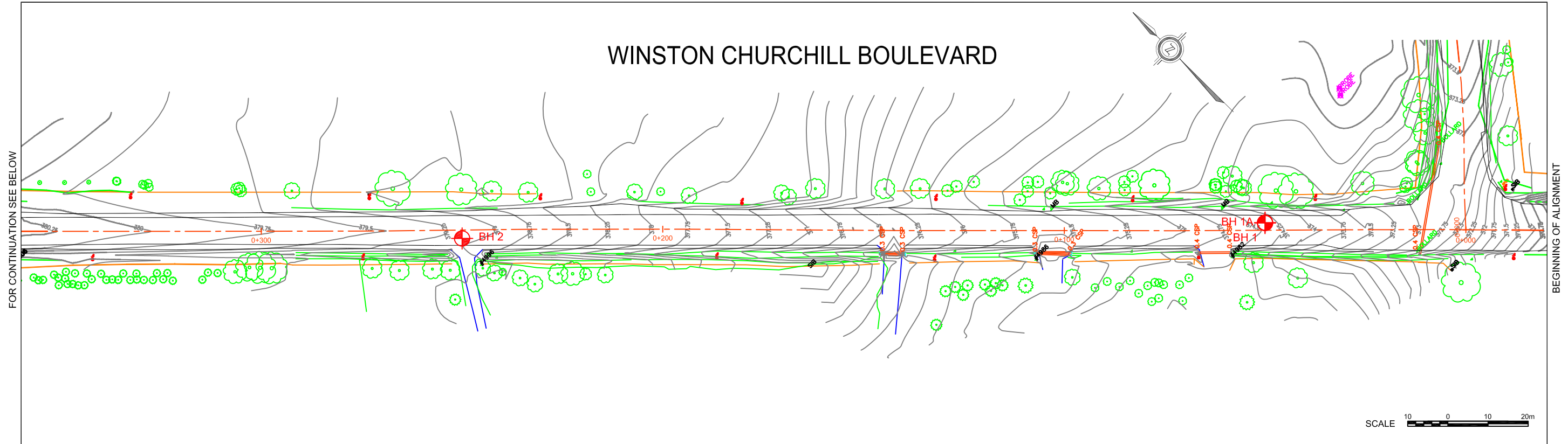


drawn	SH
approved	PC / BF
date	FEB., 2014
scale	N.T.S.
original size	Letter



client:	<b>HDR CORPORATION</b>	
project:	<b>GEOTECHNICAL INVESTIGATION REGIONAL ROAD CORRIDOR BOUNDED BY WINSTON CHURCHILL BLVD., BUSH ST., OLD MAIN ST., MISSISSAUGA RD., OLDE BASELINE RD. WELLINGTON, ONTARIO</b>	
title:	<b>SITE LOCATION PLAN</b>	
project no:	<b>GEOTETOB21649AA</b>	drawing no: <b>1</b>

# WINSTON CHURCHILL BOULEVARD

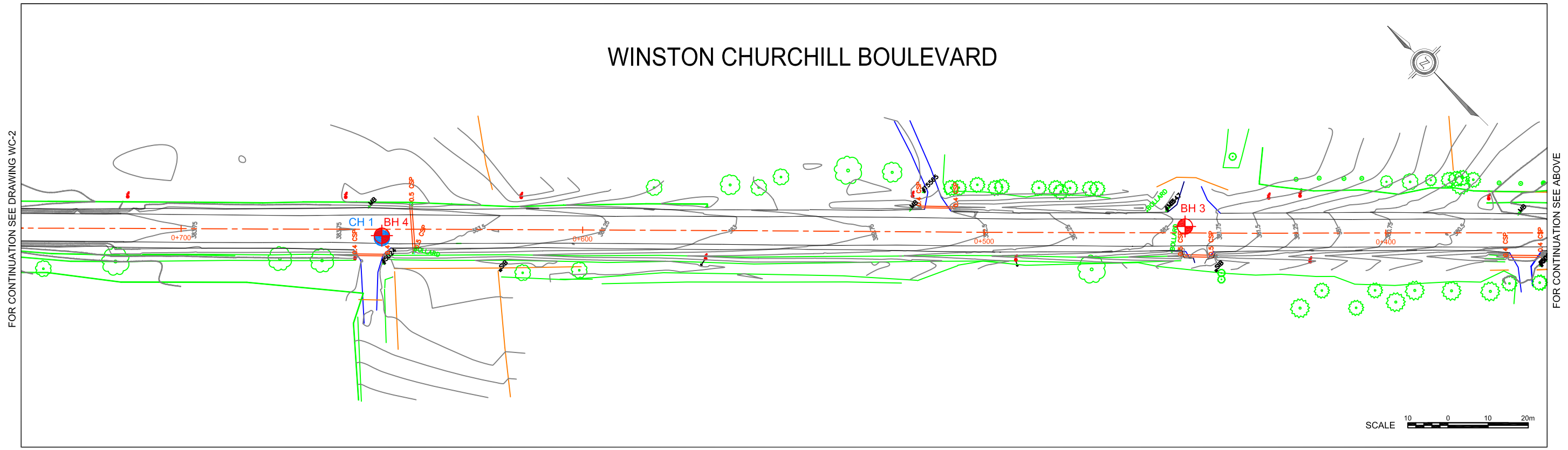


FOR CONTINUATION SEE BELOW

BEGINNING OF ALIGNMENT

SCALE 10 0 10 20m

# WINSTON CHURCHILL BOULEVARD



FOR CONTINUATION SEE DRAWING WC-2

FOR CONTINUATION SEE ABOVE

SCALE 10 0 10 20m

### LEGEND

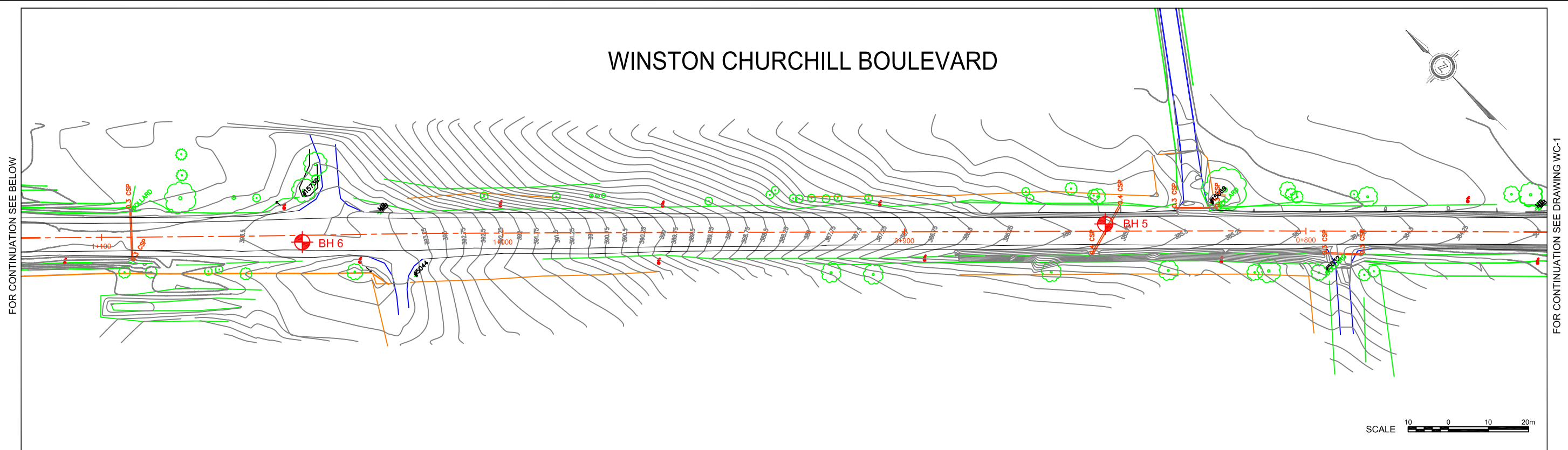
- BH BOREHOLE
- CH CORE HOLE

drawn	SH
approved	PC / BF
date	FEB., 2014
scale	AS SHOWN
original size	Tabloid

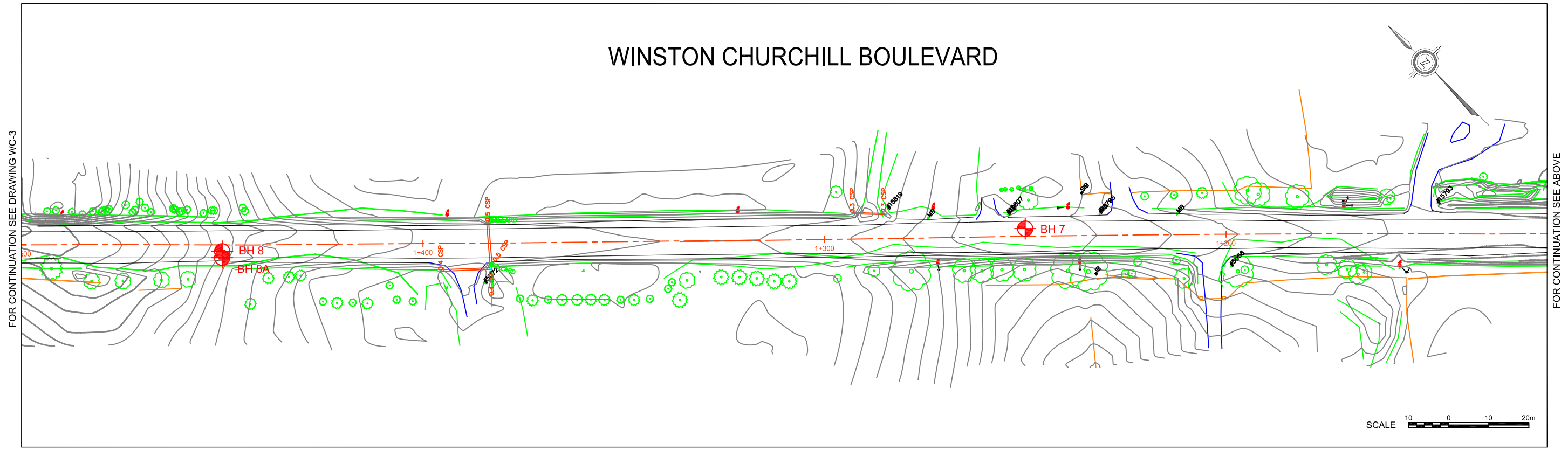


client:	<b>HDR CORPORATION</b>	
project:	<b>GEOTECHNICAL INVESTIGATION REGIONAL ROAD CORRIDOR BOUNDED BY WINSTON CHURCHILL BLVD., BUSH ST., OLD MAIN ST., MISSISSAUGA RD., OLDE BASELINE RD. WELLINGTON, ONTARIO</b>	
title:	<b>BOREHOLE LOCATION PLAN</b>	
project no:	<b>GEOTETOB21649AA</b>	drawing no: <b>WC-1</b>

# WINSTON CHURCHILL BOULEVARD



# WINSTON CHURCHILL BOULEVARD



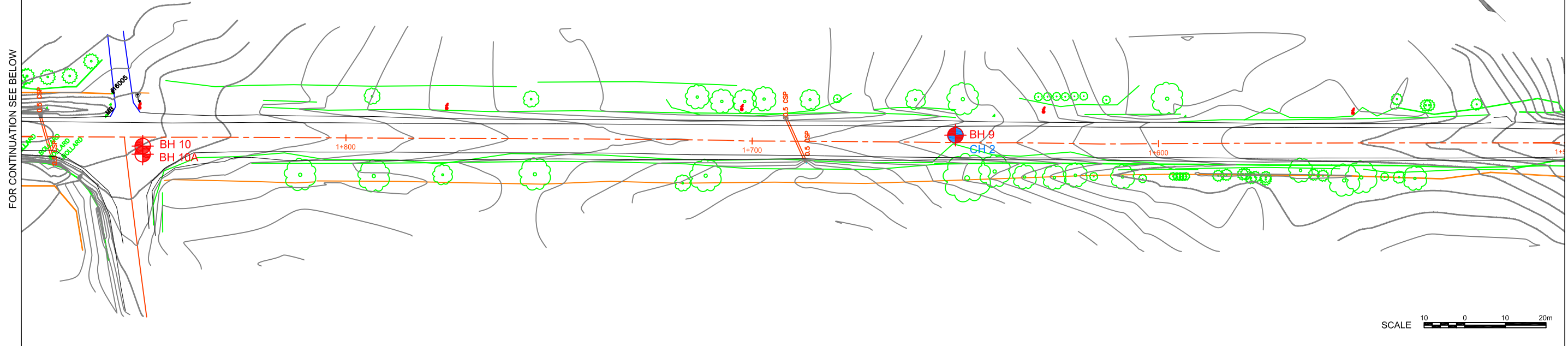
- LEGEND**
- ⊕ BH BOREHOLE
  - ⊕ CH CORE HOLE

drawn	SH
approved	PC / BF
date	FEB., 2014
scale	AS SHOWN
original size	Tabloid

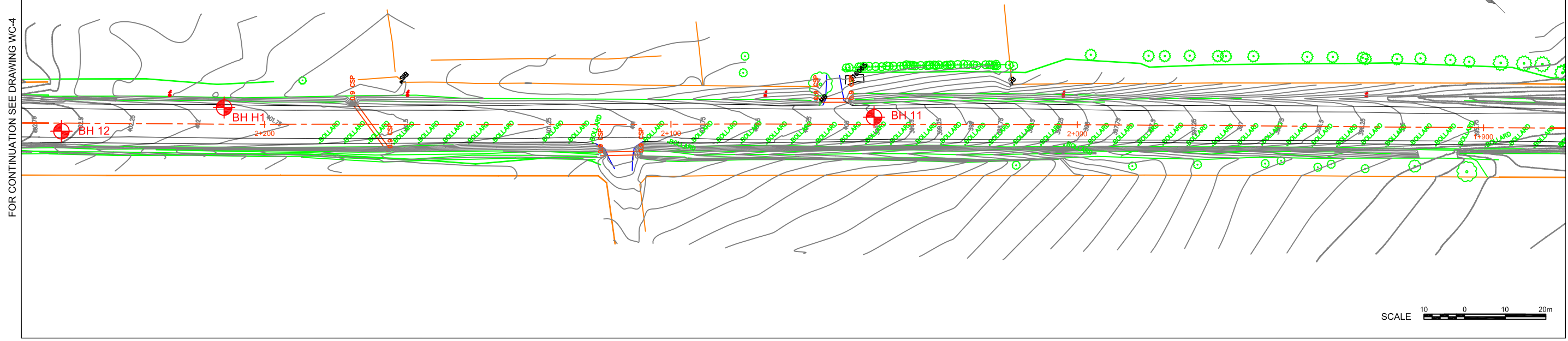


client:	<b>HDR CORPORATION</b>	
project:	<b>GEOTECHNICAL INVESTIGATION REGIONAL ROAD CORRIDOR BOUNDED BY WINSTON CHURCHILL BLVD., BUSH ST., OLD MAIN ST., MISSISSAUGA RD., OLDE BASELINE RD. WELLINGTON, ONTARIO</b>	
title:	<b>BOREHOLE LOCATION PLAN</b>	
project no:	<b>GEOTETOB21649AA</b>	drawing no: <b>WC-2</b>

# WINSTON CHURCHILL BOULEVARD



# WINSTON CHURCHILL BOULEVARD



- LEGEND**
- BH BOREHOLE
  - CH CORE HOLE

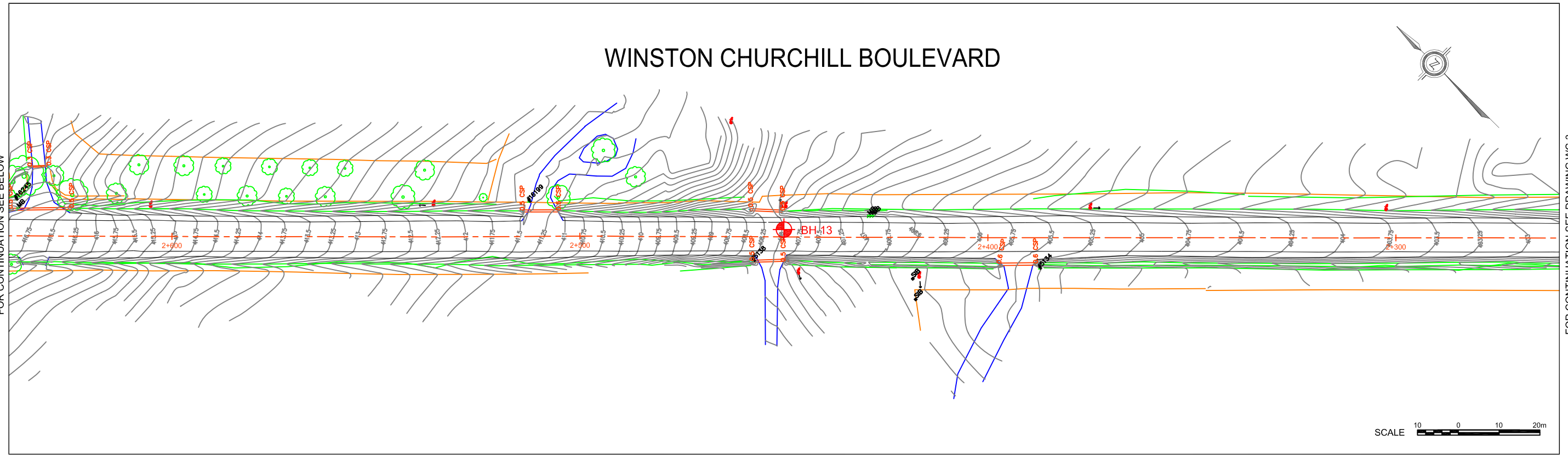
drawn	SH
approved	PC / BF
date	FEB., 2014
scale	AS SHOWN
original size	Tabloid



client:	<b>HDR CORPORATION</b>	
project:	<b>GEOTECHNICAL INVESTIGATION</b> <b>REGIONAL ROAD CORRIDOR BOUNDED BY WINSTON CHURCHILL BLVD.,</b> <b>BUSH ST., OLD MAIN ST., MISSISSAUGA RD., OLDE BASELINE RD.</b> <b>WELLINGTON, ONTARIO</b>	
title:	<b>BOREHOLE LOCATION PLAN</b>	
project no:	<b>GEOTETOB21649AA</b>	drawing no: <b>WC-3</b>

# WINSTON CHURCHILL BOULEVARD

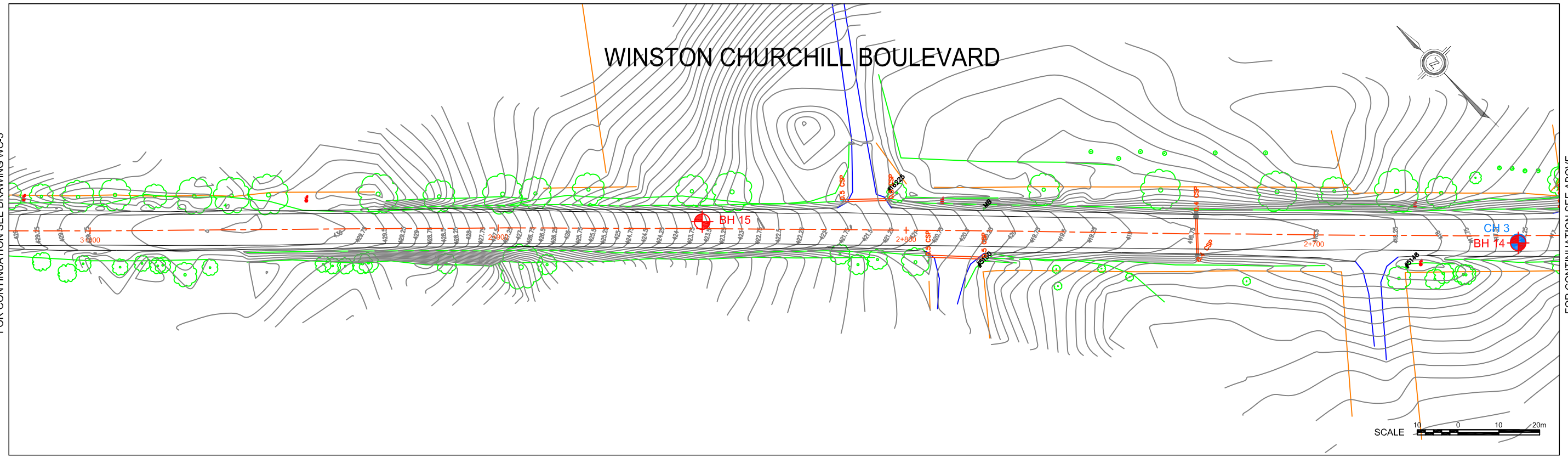
FOR CONTINUATION SEE BELOW



FOR CONTINUATION SEE DRAWING WC-3



# WINSTON CHURCHILL BOULEVARD

FOR CONTINUATION SEE DRAWING WC-5



FOR CONTINUATION SEE ABOVE

## LEGEND

-  BH BOREHOLE
-  CH CORE HOLE

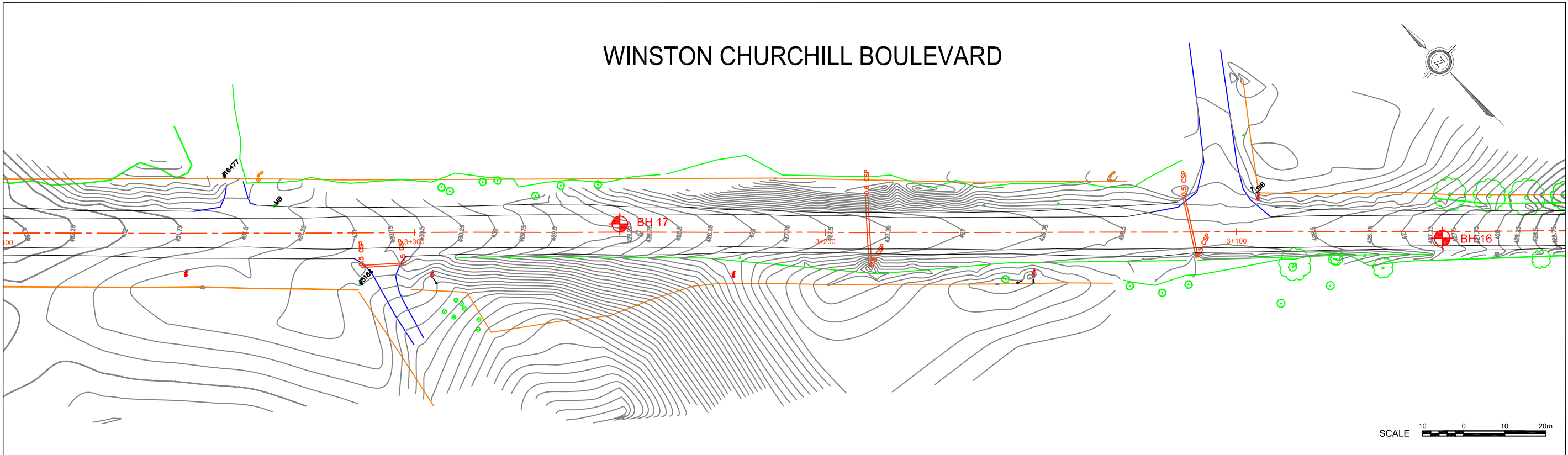
drawn	SH
approved	PC / BF
date	FEB., 2014
scale	AS SHOWN
original size	Tabloid



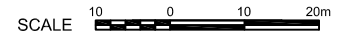
client:	<b>HDR CORPORATION</b>	
project:	<b>GEOTECHNICAL INVESTIGATION REGIONAL ROAD CORRIDOR BOUNDED BY WINSTON CHURCHILL BLVD., BUSH ST., OLD MAIN ST., MISSISSAUGA RD., OLDE BASELINE RD. WELLINGTON, ONTARIO</b>	
title:	<b>BOREHOLE LOCATION PLAN</b>	
project no:	<b>GEOTETOB21649AA</b>	drawing no: <b>WC-4</b>

# WINSTON CHURCHILL BOULEVARD

FOR CONTINUATION SEE BELOW

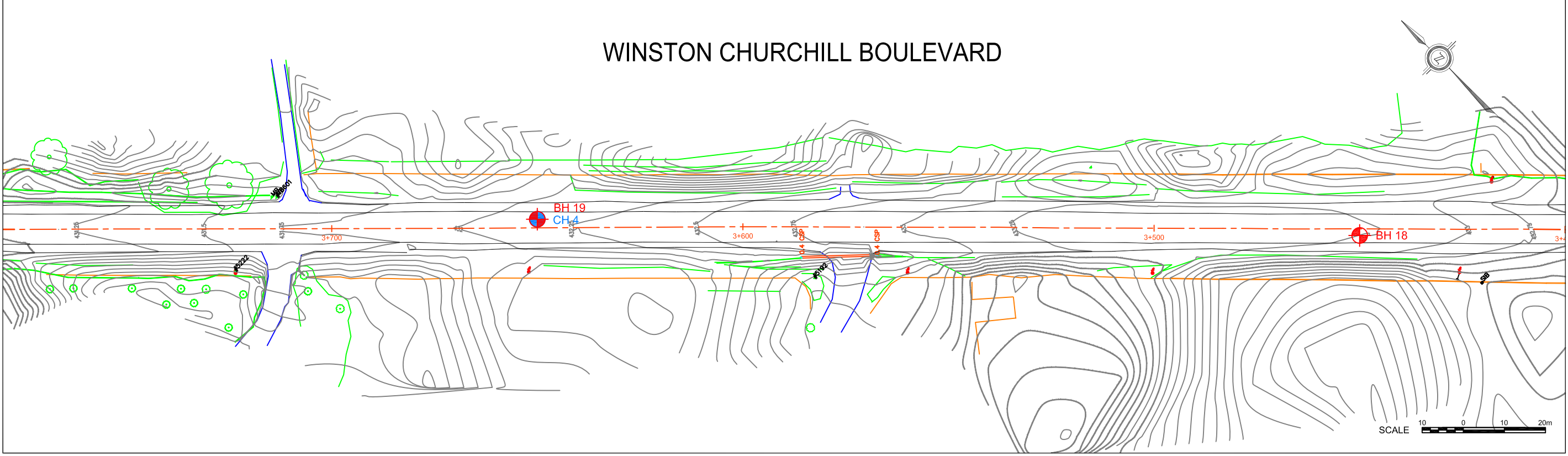


FOR CONTINUATION SEE DRAWING WC-4

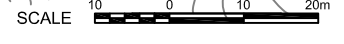


# WINSTON CHURCHILL BOULEVARD

FOR CONTINUATION SEE DRAWING WC-6



FOR CONTINUATION SEE ABOVE



- LEGEND**
- BH BOREHOLE
  - CH CORE HOLE

drawn	SH
approved	PC / BF
date	FEB., 2014
scale	AS SHOWN
original size	Tabloid

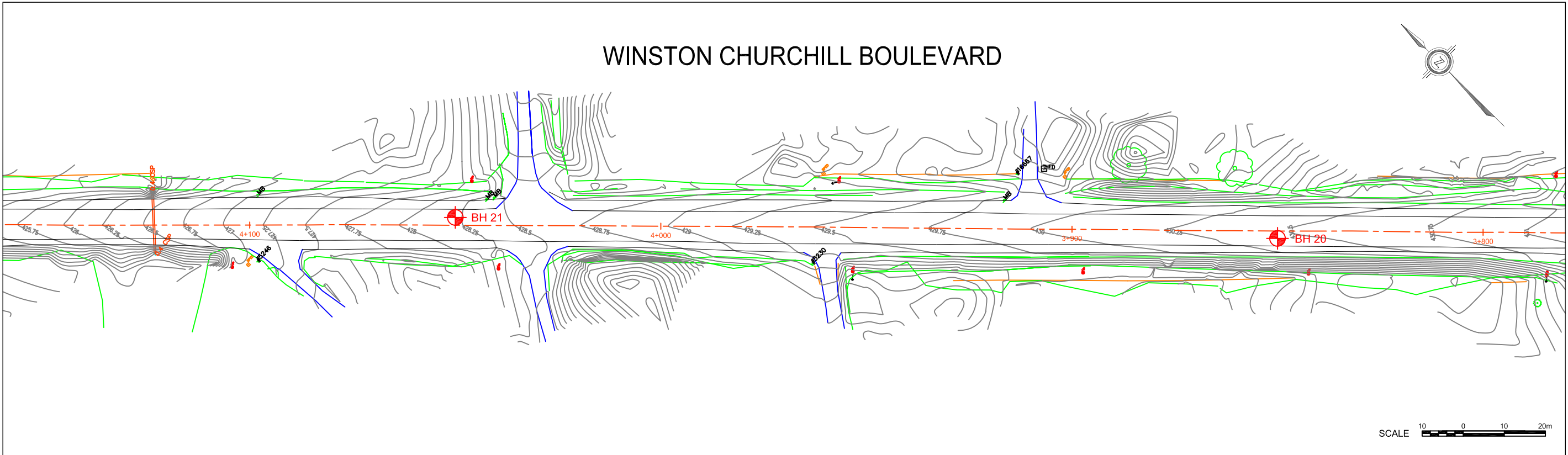


client:	<b>HDR CORPORATION</b>	
project:	<b>GEOTECHNICAL INVESTIGATION                  REGIONAL ROAD CORRIDOR BOUNDED BY WINSTON CHURCHILL BLVD.,                  BUSH ST., OLD MAIN ST., MISSISSAUGA RD., OLDE BASELINE RD.                  WELLINGTON, ONTARIO</b>	
title:	<b>BOREHOLE LOCATION PLAN</b>	
project no:	<b>GEOTETOB21649AA</b>	drawing no: <b>WC-5</b>



# WINSTON CHURCHILL BOULEVARD

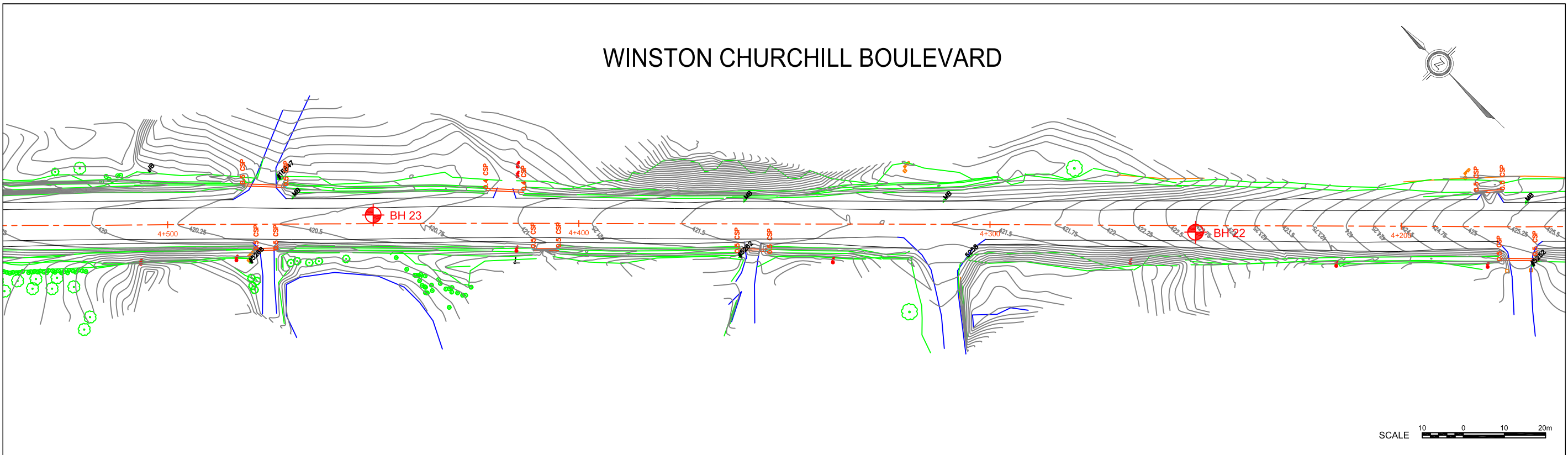
FOR CONTINUATION SEE BELOW



FOR CONTINUATION SEE DRAWING WC-5



# WINSTON CHURCHILL BOULEVARD

FOR CONTINUATION SEE DRAWING WC-7



FOR CONTINUATION SEE ABOVE

### LEGEND

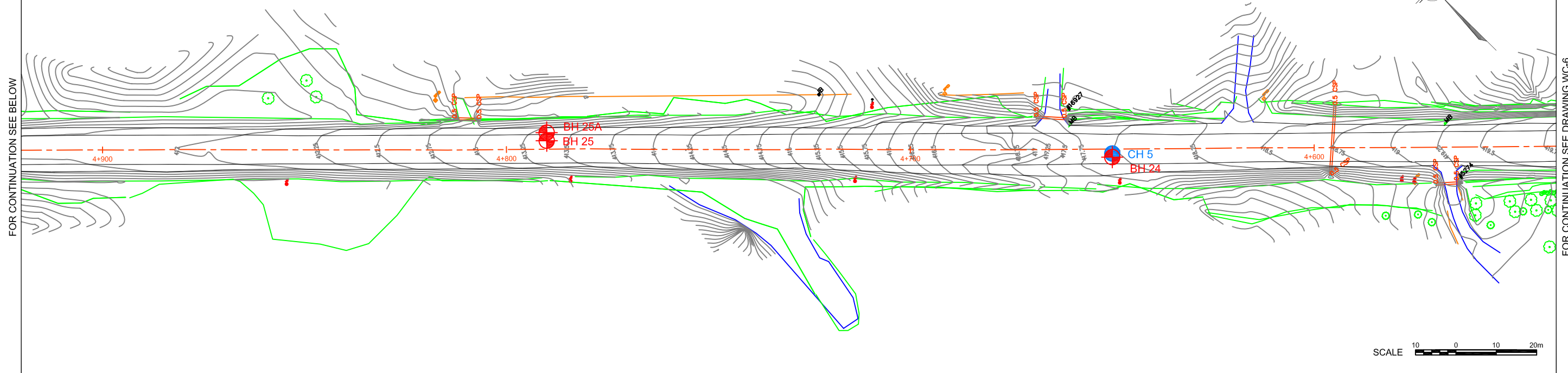
-  BH BOREHOLE
-  CH CORE HOLE

drawn	SH
approved	PC / BF
date	FEB., 2014
scale	AS SHOWN
original size	Tabloid



client:	<b>HDR CORPORATION</b>	
project:	<b>GEOTECHNICAL INVESTIGATION REGIONAL ROAD CORRIDOR BOUNDED BY WINSTON CHURCHILL BLVD., BUSH ST., OLD MAIN ST., MISSISSAUGA RD., OLDE BASELINE RD. WELLINGTON, ONTARIO</b>	
title:	<b>BOREHOLE LOCATION PLAN</b>	
project no:	<b>GEOTETOB21649AA</b>	drawing no: <b>WC-6</b>

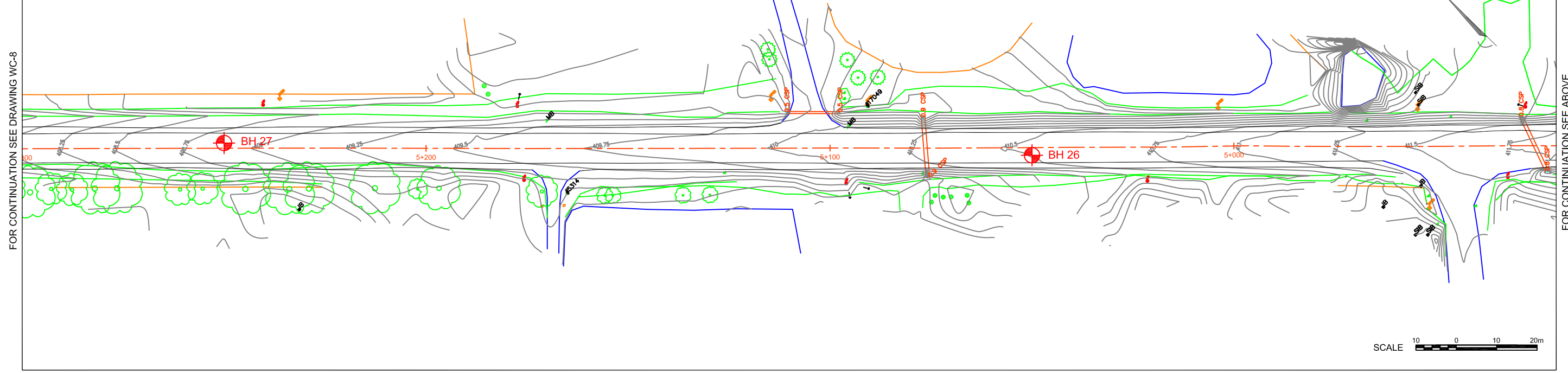
# WINSTON CHURCHILL BOULEVARD



FOR CONTINUATION SEE BELOW



FOR CONTINUATION SEE DRAWING WC-6

# WINSTON CHURCHILL BOULEVARD



FOR CONTINUATION SEE DRAWING WC-8

FOR CONTINUATION SEE ABOVE

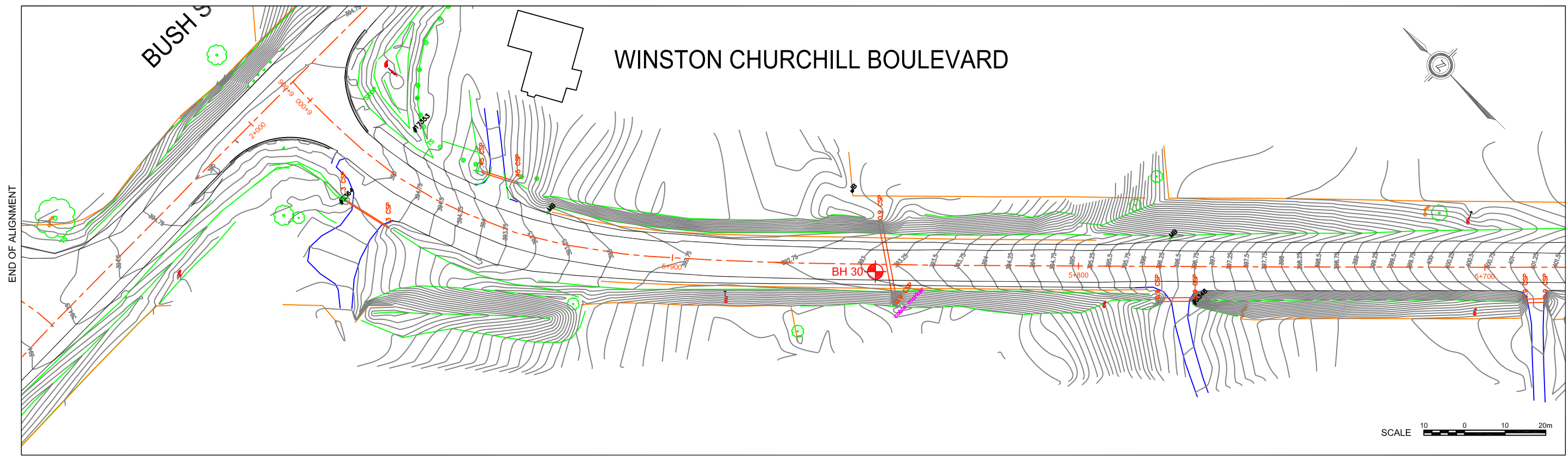
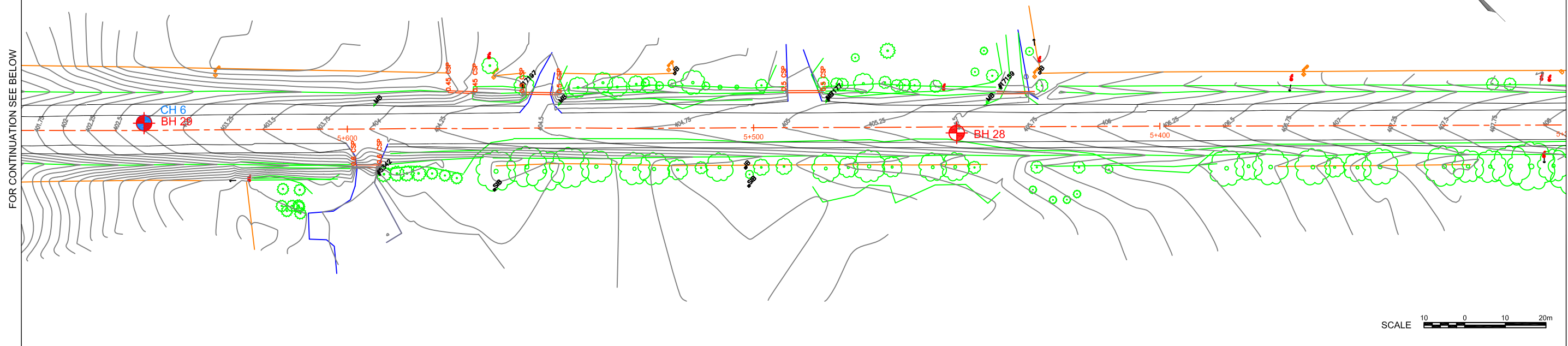
- LEGEND**
-  BH BOREHOLE
  -  CH CORE HOLE



drawn	SH
approved	PC / BF
date	FEB., 2014
scale	AS SHOWN
original size	Tabloid



client:	<b>HDR CORPORATION</b>	
project:	<b>GEOTECHNICAL INVESTIGATION                  REGIONAL ROAD CORRIDOR BOUNDED BY WINSTON CHURCHILL BLVD.,                  BUSH ST., OLD MAIN ST., MISSISSAUGA RD., OLDE BASELINE RD.                  WELLINGTON, ONTARIO</b>	
title:	<b>BOREHOLE LOCATION PLAN</b>	
project no:	<b>GEOTETOB21649AA</b>	drawing no: <b>WC-7</b>

# WINSTON CHURCHILL BOULEVARD



- LEGEND**
-  BH BOREHOLE
  -  CH CORE HOLE

drawn	SH
approved	PC / BF
date	FEB., 2014
scale	AS SHOWN
original size	Tabloid

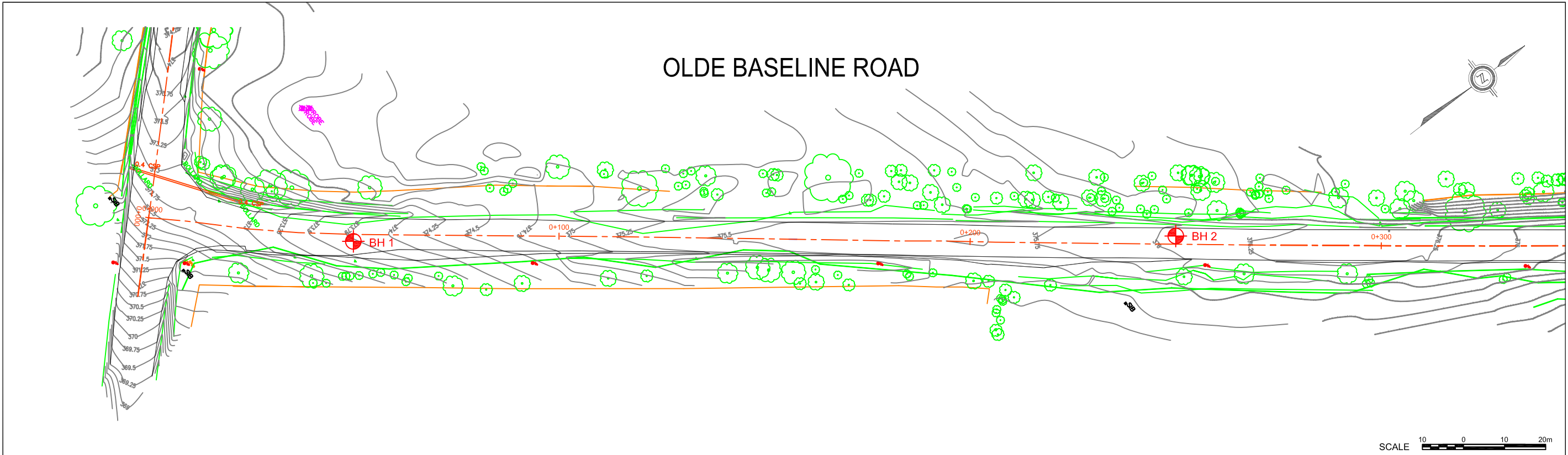


client:	<b>HDR CORPORATION</b>	
project:	<b>GEOTECHNICAL INVESTIGATION                  REGIONAL ROAD CORRIDOR BOUNDED BY WINSTON CHURCHILL BLVD.,                  BUSH ST., OLD MAIN ST., MISSISSAUGA RD., OLDE BASELINE RD.                  WELLINGTON, ONTARIO</b>	
title:	<b>BOREHOLE LOCATION PLAN</b>	
project no:	<b>GEOTETOB21649AA</b>	drawing no: <b>WC-8</b>

# OLDE BASELINE ROAD

BEGINNING OF ALIGNMENT

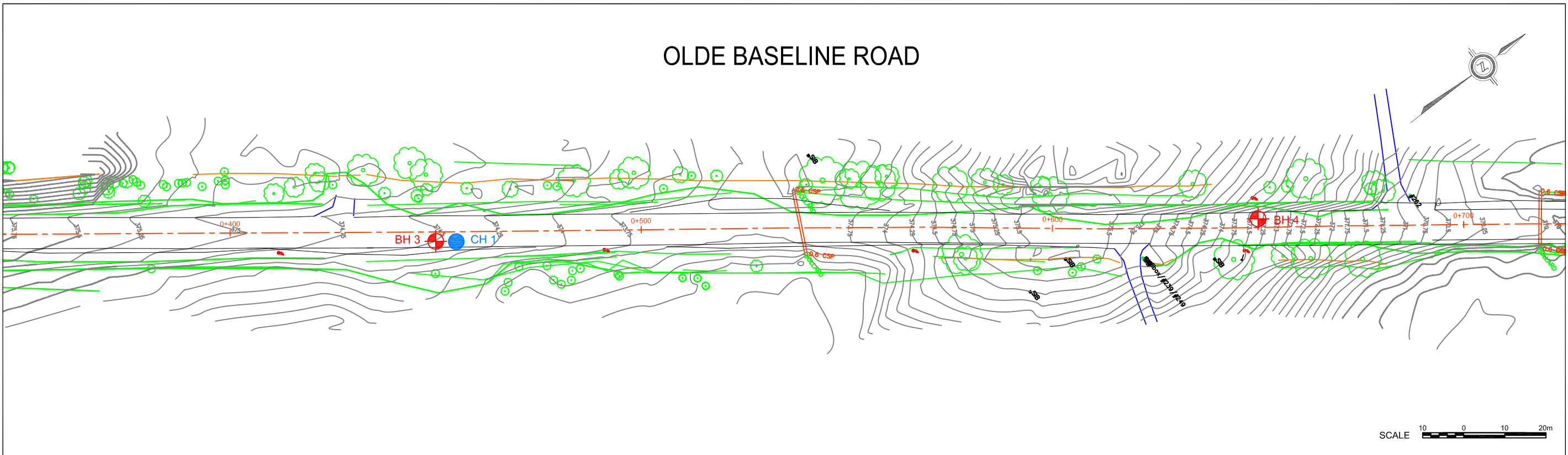
FOR CONTINUATION SEE BELOW



# OLDE BASELINE ROAD

FOR CONTINUATION SEE ABOVE

FOR CONTINUATION SEE DRAWING OB-2



### LEGEND

- ⊕ BH BOREHOLE
- CH CORE HOLE

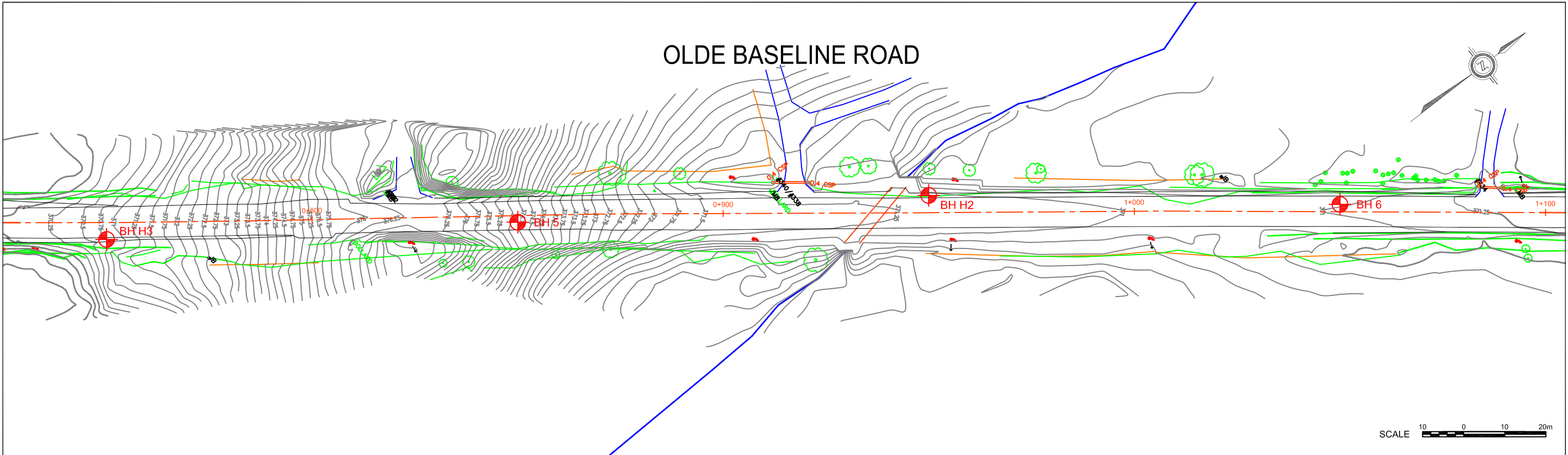
drawn	SH
approved	PC / BF
date	FEB., 2014
scale	AS SHOWN
original size	Tabloid



client:	<b>HDR CORPORATION</b>	
project:	<b>GEOTECHNICAL INVESTIGATION REGIONAL ROAD CORRIDOR BOUNDED BY WINSTON CHURCHILL BLVD., BUSH ST., OLD MAIN ST., MISSISSAUGA RD., OLDE BASELINE RD. WELLINGTON, ONTARIO</b>	
title:	<b>BOREHOLE LOCATION PLAN</b>	
project no:	<b>GEOTETOB21649AA</b>	drawing no: <b>OB-1</b>

# OLDE BASELINE ROAD

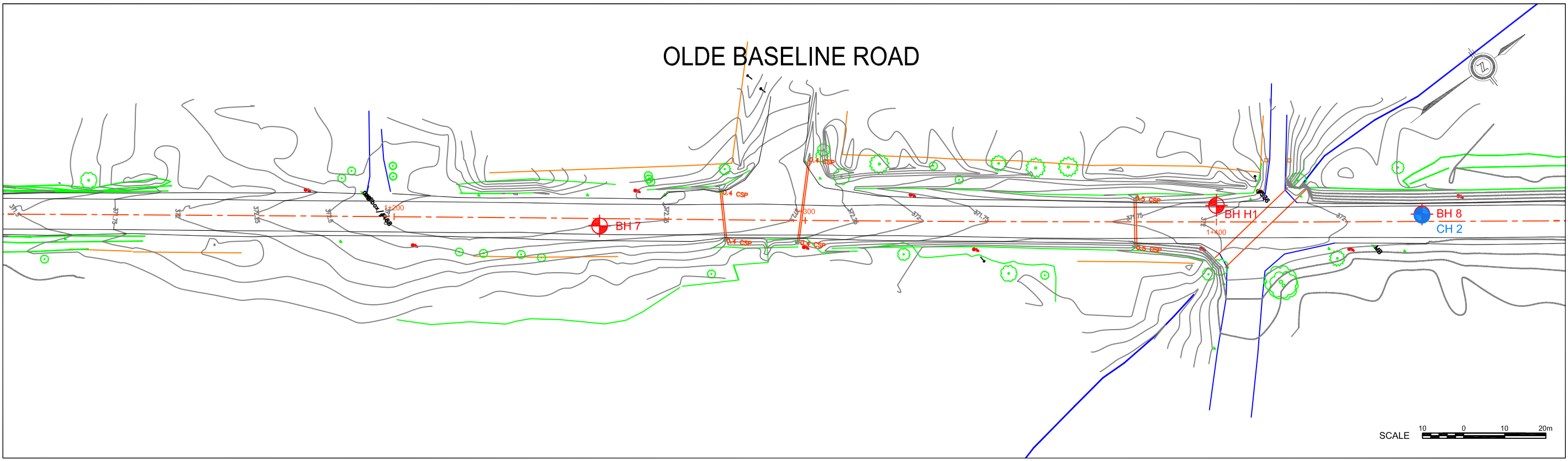
FOR CONTINUATION SEE DRAWING OB-1



FOR CONTINUATION SEE BELOW

# OLDE BASELINE ROAD

FOR CONTINUATION SEE ABOVE



FOR CONTINUATION SEE DRAWING OB-3

- LEGEND**
- ⊕ BH BOREHOLE
  - CH CORE HOLE

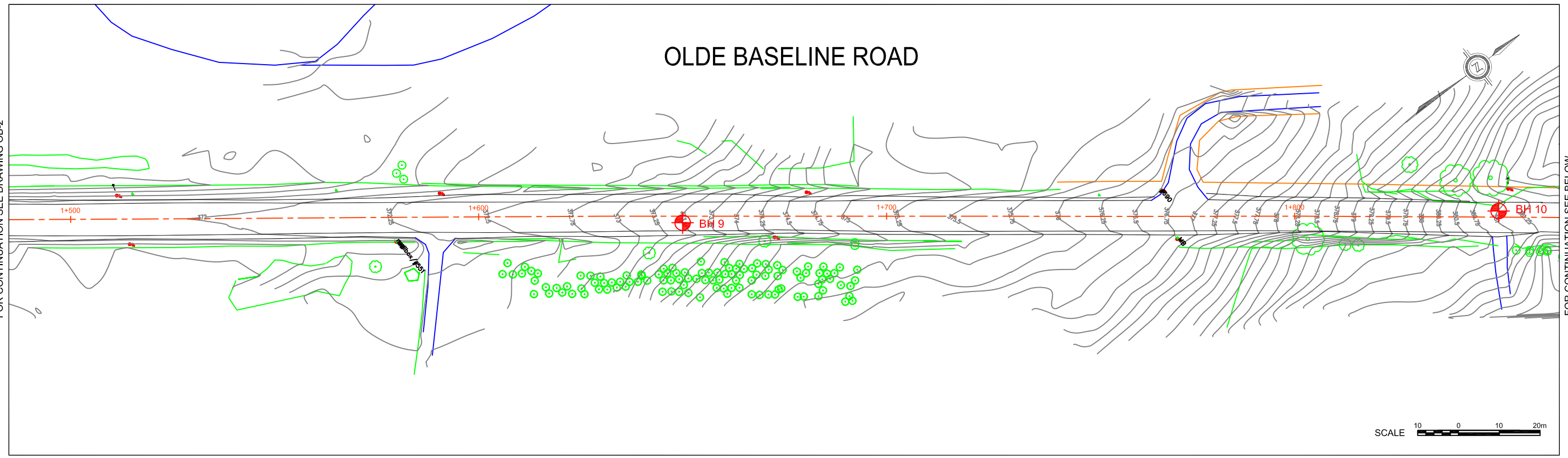
drawn	SH
approved	PC / BF
date	FEB., 2014
scale	AS SHOWN
original size	Tabloid



client:	<b>HDR CORPORATION</b>	
project:	<b>GEOTECHNICAL INVESTIGATION REGIONAL ROAD CORRIDOR BOUNDED BY WINSTON CHURCHILL BLVD., BUSH ST., OLD MAIN ST., MISSISSAUGA RD., OLDE BASELINE RD. WELLINGTON, ONTARIO</b>	
title:	<b>BOREHOLE LOCATION PLAN</b>	
project no:	<b>GEOTETOB21649AA</b>	drawing no: <b>OB-2</b>

# OLDE BASELINE ROAD

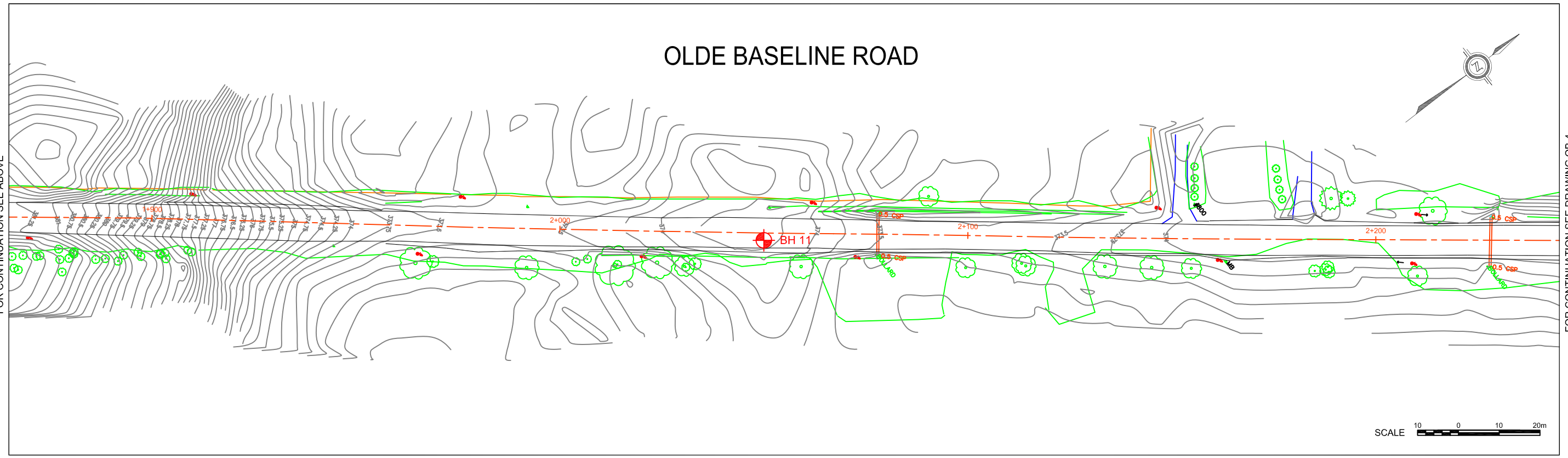
FOR CONTINUATION SEE DRAWING OB-2



FOR CONTINUATION SEE BELOW



# OLDE BASELINE ROAD

FOR CONTINUATION SEE ABOVE



FOR CONTINUATION SEE DRAWING OB-4

### LEGEND

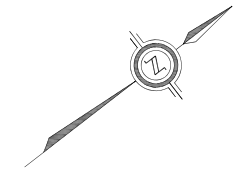
-  BH BOREHOLE
-  CH CORE HOLE

drawn	SH
approved	PC / BF
date	FEB., 2014
scale	AS SHOWN
original size	Tabloid

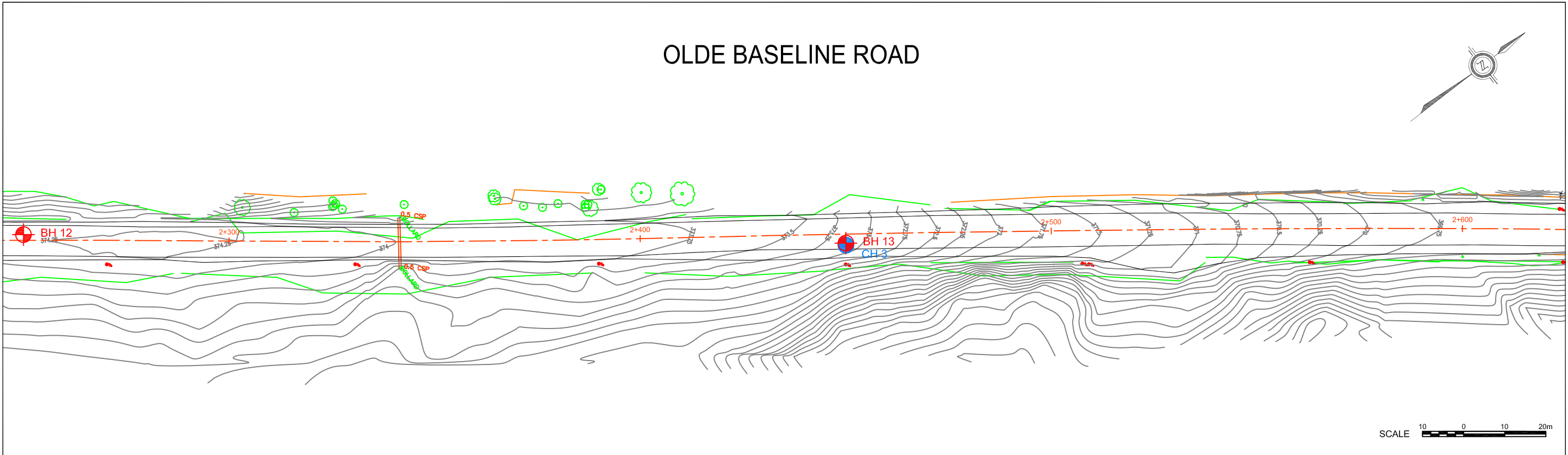


client:	<b>HDR CORPORATION</b>	
project:	<b>GEOTECHNICAL INVESTIGATION REGIONAL ROAD CORRIDOR BOUNDED BY WINSTON CHURCHILL BLVD., BUSH ST., OLD MAIN ST., MISSISSAUGA RD., OLDE BASELINE RD. WELLINGTON, ONTARIO</b>	
title:	<b>BOREHOLE LOCATION PLAN</b>	
project no:	<b>GEOTETOB21649AA</b>	drawing no: <b>OB-3</b>

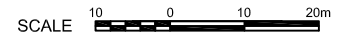
# OLDE BASELINE ROAD



FOR CONTINUATION SEE DRAWING OB-3

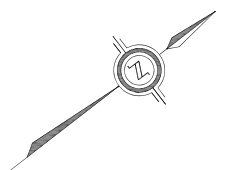


FOR CONTINUATION SEE BELOW

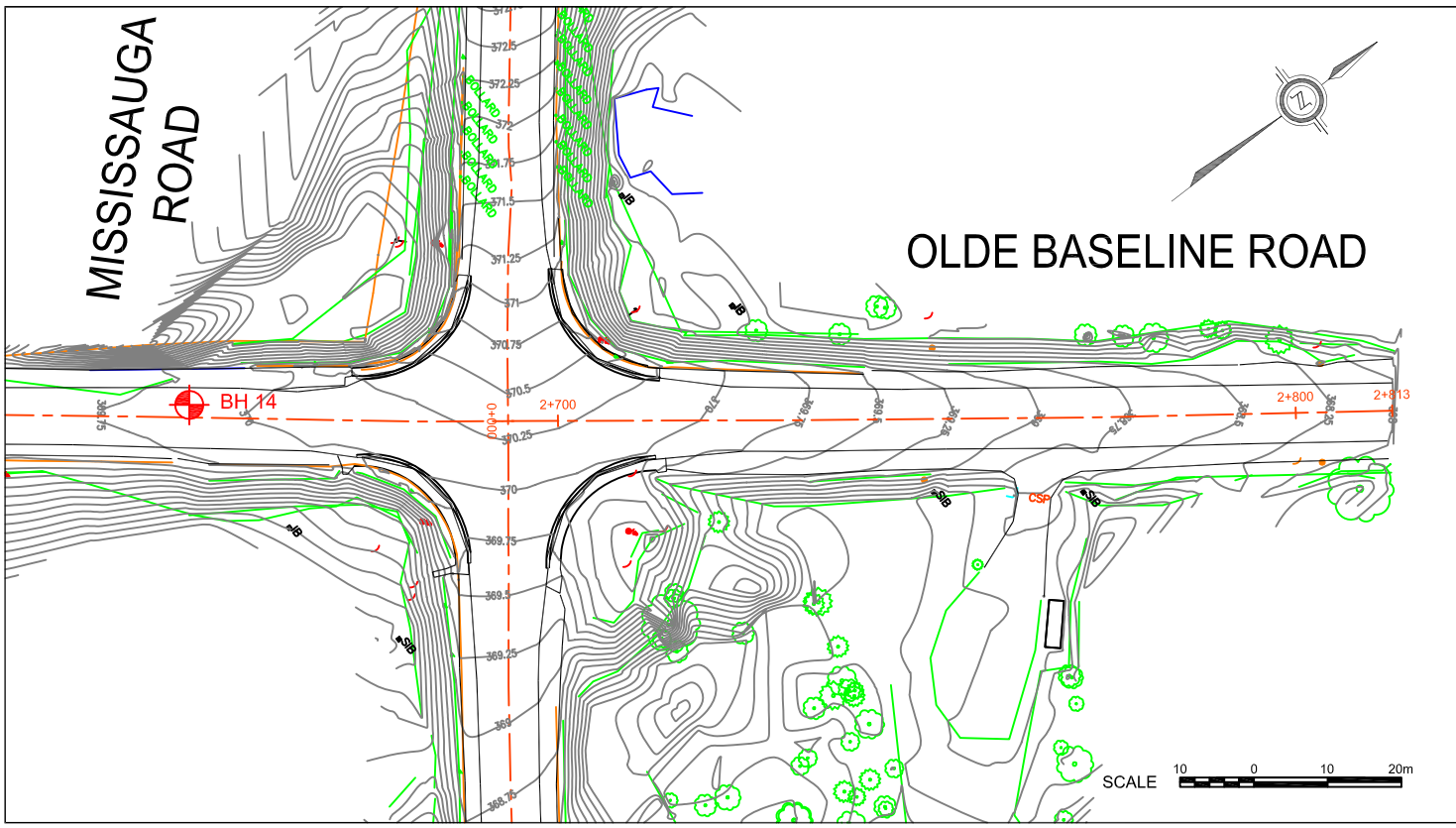


# MISSISSAUGA ROAD

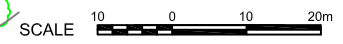
# OLDE BASELINE ROAD



FOR CONTINUATION SEE ABOVE



END OF ALIGNMENT



### LEGEND

- BH BOREHOLE
- CH CORE HOLE

drawn	SH	
approved	PC / BF	
date	FEB., 2014	
scale	AS SHOWN	
original size	Tabloid	

client:	<b>HDR CORPORATION</b>	
project:	<b>GEOTECHNICAL INVESTIGATION                  REGIONAL ROAD CORRIDOR BOUNDED BY WINSTON CHURCHILL BLVD.,                  BUSH ST., OLD MAIN ST., MISSISSAUGA RD., OLDE BASELINE RD.                  WELLINGTON, ONTARIO</b>	
title:	<b>BOREHOLE LOCATION PLAN</b>	
project no:	<b>GEOTETOB21649AA</b>	drawing no: <b>OB-4</b>

Geotechnical Investigation Report Improvements to  
Regional Road Corridor Bounded by Winston Churchill Blvd., Bush St., Old Main St., Mississauga Rd., Olde Base Line Rd.  
Wellington, Ontario  
Regional Municipality of Peel  
Peel Project 11-4360

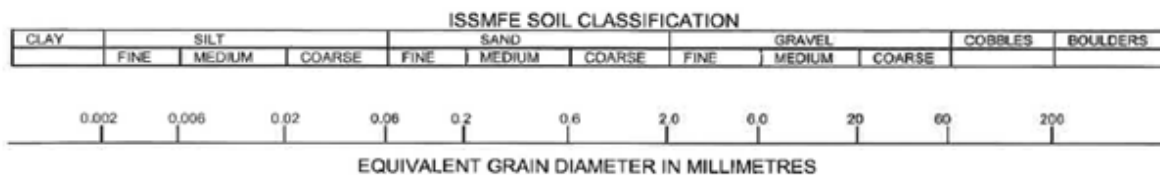
# Appendix A

## Borehole Logs



## Notes on Sample Descriptions

1. All sample descriptions included in this report follow the soil classification system as provided by the “*Canadian Foundation Engineering Manual*”, 4<sup>th</sup> Edition. This system follows the standard proposed by the International Society for Soil Mechanics and Foundation Engineering as shown below. Laboratory grain size analyses provided by Coffey Geotechnics also follow the same system. Different classification systems may be used by others; one such system is the Unified Soil Classification. Please note that, with the exception of those samples where a grain size analysis has been made, all the samples are classified visually.



2. **Fill:** Where fill is designated on the borehole log it is defined as indicated by the sample recovered during the boring process. The reader is cautioned that fills are heterogeneous in nature and variable in density of degree of compaction. The borehole description may therefore not be applicable as a general description of site fill materials. All fills should be expected to contain obstruction such as wood, large concrete pieces or subsurface basements, floors, tanks, etc.; none of these may have been encountered in the boreholes. Since boreholes cannot accurately define the contents of the fill, test pits are recommended to provide supplementary information. Despite the use of test pits, the heterogeneous nature of fill will leave some ambiguity as to the exact composition of the fill. Most fills contain pockets, seams, or layers of organically contaminated soil. This organics material can result in the generation of methane gas and/or significant ongoing and future settlements. Fill at this site may have been monitored for the presence of methane gas and, if so, the results are given on the borehole logs. The monitoring process does not indicate the volume of gas that can be potentially generated nor does it pinpoint the source of the gas. These readings are to advise of the presence of gas only, and a detailed study is recommended for sites where any explosive gas/methane is detected. Some fill material may be contaminated by toxic/hazardous waste that renders it unacceptable for deposition in any but designated land fill sites; unless specifically stated the fill on this site has not been tested for contaminants that may be considered toxic or hazardous. This testing and a potential hazard study can be undertaken if requested. In most residential/commercial areas undergoing reconstruction, buried oil tanks are common and are generally not detected in a conventional geotechnical site investigation.
3. **Till:** The term till on the borehole logs indicates that the material originates from a geological process associated with glaciations. Because of this geological process the till must be considered heterogeneous in composition and as such may contain pockets and/or seams of material such as sand, gravel, silt or clay. Till often contains cobbles (60 to 200mm) or boulders (over 200mm). Contractors may therefore encounter cobbles and boulders during excavation, even if they are not indicated by the borings. It should be appreciated that normal sampling equipment cannot differentiate the size or type of any obstruction. Because of the horizontal and vertical variability of till, the samples description may be applicable to a very limited zone; caution is therefore essential when dealing with sensitive excavations or dewatering programs in till materials.

**TABLE 3.1** *Compactness Condition of Sands from Standard Penetration Tests*

Compactness Condition	SPT N-INDEX (blows per 0.3 m)
Very loose	0 – 4
Loose	4 – 10
Compact	10 – 30
Dense	30 – 50
Very dense	Over 50

**TABLE 3.2** *Approximate Consistency of Cohesive Soils*

Consistency	Field Identification
Very soft	Easily penetrated several centimeters by the fist
Soft	Easily penetrated several centimeters by the thumb
Firm	Can be penetrated several centimeters by the thumb with moderate effort
Stiff	Readily indented by the thumb but penetrated only with great effort
Very stiff	Readily indented by the thumb nail
Hard	Indented with difficulty by the thumbnail

**TABLE 3.3** *Consistency and Undrained Shear Strength of Cohesive Soils*

Consistency	Undrained Shear Strength (kPa)	Spt N-Index (blows/0.3m)
Very soft	< 12	< 2
Soft	12 - 25	2 - 4
Firm	25-50	4 - 8
Stiff	50 - 100	8 - 15
Very stiff	100 - 200	15 - 30
Hard	> 200	>30

Source: Canadian Geotechnical Society "Canadian Foundation Engineering Manual", 4<sup>th</sup> Edition dated 2006.

**Pavement Structur - Winston Churchill Boulevard**

**Note:** Offsets are measured from centerline (C/L) of existing Winston Churchill Blvd. Station 0+000 is at the intersection of Olde Base Line Rd and Winston Churchill Blvd. Stations increase from a south to north direction.

<b>0-050, 1.9 m Rt C/L, (MID)</b>	<b>BH# 1A</b>
0 - 45 Asph	
45 - 650 Gry Gr Sa, Tr Si, Moist (Probable Recycled Asphalt)	AS1
650 - 900 Br Gr Sa, Some Si, Moist	AS2
900 - 1.5 Br Sa and Si Some Cl Tr Gr, Moist	AS3

Sample AS1

FMC	2.2%
% Passing 4.75mm	60.8
% Passing 75µm	5.4
Lab Class: Not acceptable as Granular A Base Material Acceptable as Granular B Type I Subbase Material	

Sample AS2

FMC	2.8%
% Passing 4.75mm	62.9
% Passing 75µm	12.2
Lab Class: Marginally acceptable as Granular B Type I Subbase Material	

Sample AS3

FMC	17.5%
% Passing 4.75mm	98.9
% Passing 75µm	57.5
% Passing 5µm	20.0
Lab Class:	LSFH

<b>0+050, 1.8 m Rt C/L, (MID)</b>	<b>BH# 1</b>
0 - 40 Asph	
40 - 320 Br Sa and Gr, Moist	AS1
320 - 1.3 Br Cl Si, Some Sa, Moist	AS2
1.3 NFP Probable Rock	

**0+250, 2.1 m Lt C/L, (MID)**

<b>BH# 2</b>	
0 - 40 Asph	40
- 400 Gry Sa and Gr, Moist	AS1
400 - 750 Gry/Br Sa and Gr, Tr Si, Moist	AS2
750 - 1.3 Rock Dust	AS3
1.3 NFP Probable Rock	

**0+450, 1.6 m Rt C/L, (MID)**

<b>BH# 3</b>	
0 - 40 Asph	
40 - 400 Probable Recycled Asphalt	
400 - 900 Br Sa and Gr, Moist	AS1
900 - 1.5 Br Sa Si, Moist	AS2

Sample AS1

FMC	4.0%
-----	------

Sample AS2

FMC 7.6%

**0+650, 2.2 m Lt C/L, (MID)**

0 - 45 Asph

**0+650, 1.6 m Lt C/L, (MID)**

0 - 45 Asph  
45 - 500 Gry Sa and Gr, Moist AS1  
500 - 900 Gry Cl Si, Tr Sa, Moist AS2  
900 - 1.3 Br Cl Si, Tr Sa, Moist AS3  
1.3 - 1.5 Lt Br, Rock Dust AS4  
1.5 NFP Probable Rock

Sample AS1

FMC 3.2%

Sample AS2

FMC 21.1%

Sample AS3

FMC 18.2%

**0+850, 1.8 m Rt C/L, (MID)**

0 - 110 Asph  
110 - 355 Br Sa and Gr, Moist AS1  
355 - 610 Br Gr Sa, Moist AS2  
610 - 900 Br Si Sa, Moist AS3

**1+050, 1.7 m Lt C/L, (MID)**

0 - 30 Asph  
30 - 300 Gry Sa and Gr, Moist AS1  
300 - 550 Br Sa and Gr, Tr Si, Moist AS2  
550 - 1.2 Br Si Cl, Tr Sa, Moist AS3

**1+250, 1.9 m Rt C/L, (MID)**

0 - 75 Asph  
75 - 560 Gry Sa and Gr, Tr Si, Moist AS1  
(Probable Recycled Asphalt)  
560 - 1.5 Br Cl Si, Moist AS2

Sample AS1

% Passing 4.75mm 51.0  
% Passing 75µm 5.4  
Lab Class: Acceptable as Granular A Base Material

Sample AS2

FMC 10.0%

**1+450, 3.2 m Lt C/L, (Sh)**

0 - 760 Br Sa and Gr, Moist  
(N= 99 Very Dense) SS1  
760 - 2.3 Br Si Sa, Tr Gr, Moist  
(N= 12, 18 Compact) SS2-SS3  
2.3 - 2.4 Lt Br Limestone Rock  
(N= 55/3" Hard) SS4  
2.4 NFP Probable Rock

<b>1+450, 1.6 m Lt C/L, (MID)</b>	<b>BH# 8</b>		
0 - 40 Asph		<u>Sample AS2</u>	
40 - 505 Br Sa and Gr, Moist	AS1	FMC	13.1%
505 - 1.5 Br Si Sa, Tr Gr, Moist	AS2		
		<b>2+050, 1.8 m Rt C/L, (MID)</b>	<b>BH# 11</b>
<b>1+650, 1.8 m Rt C/L, (MID)</b>	<b>Core# 2</b>	0 - 45 Asph	
0 - 85 Asph		45 - 380 Br Sa and Gr, Moist	AS1
		380 - 1.5 Br Si Sa, Tr Gr, Moist	AS2
<b>1+650, 1.8 m Rt C/L, (MID)</b>	<b>BH# 9</b>		
0 - 85 Asph		<b>2+210, 4.1 m Rt C/L, (Sh)</b>	<b>BH# H1</b>
85 - 535 Br Sa and Gr, Moist	AS1	0 - 760 Gry Recycled Asphalt, Moist	
535 - 1.5 Br Si Sa, Tr Gr, Moist	AS2	(N= 30 Compact)	SS1
		760 - 1.5 Br Sa and Gr, Moist	
		(N= 8 Loose)	SS2
<b>1+850, 4.2 m Lt C/L, (Sh)</b>	<b>BH# 10A</b>	1.5 - 3.8 Gry/Br, Cl Si, Moist	
0 - 760 Br Sa and Gr, Moist		(Seam @ 2.6m: Br Si Sa, Tr Gr, Wet)	
(N= 92 Very Dense)	SS1	(N= 8, 11, 17 Stiff to Very Stiff)	SS3-
760 - 3.0 Br Sa Si, Tr Gr, Moist		SS5	
(N= 9, 21, 33 Loose to Dense)	SS2-SS4	3.8 - 4.6 Gry/Br Si Sa, Tr Gr, Moist	
3.0 - 3.9 Br Si Sa, Wet, (Till)		(N= 26 Compact)	SS6
(N= 19, 50/3" Compact)	SS5-SS6	4.6 - 5.0 Gry Sa and Gr, Moist	
3.9 NFP Probable Rock		(N= 92 Very Dense)	SS7
		5.0 NFP Probable Rock	
<b>1+850, 2.2 m Lt C/L, (MID)</b>	<b>BH# 10</b>		
0 - 100 Asph		<b>2+250, 2.0 m Lt C/L, (MID)</b>	<b>BH# 12</b>
100 - 505 Br Sa and Gr, Moist	AS1	0 - 40 Asph	
505 - 1.5 Br Sa Si, Tr Cl, Moist, (Till)	AS2	40 - 290 Gry Sa and Gr, Moist	AS1
		290 - 600 Br Sa and Gr, Tr Si, Moist	AS2
<u>Sample AS1</u>		600 - 1.5 Br Sa Si, Tr Cl, Moist	AS3
FMC	7.7%		

<b>2+450, 1.8 m Rt C/L, (MID)</b>		<b>BH# 13</b>
0 - 25	Asph	
25 - 305	Gry Sa, With Gr, Some Si, Moist	AS1
305 - 760	Br Sa, With Si and Gr, Moist	AS2
760 - 1.5	Gry Sa Si, With Cl, Tr Gr, Moist	AS3

Sample AS1

FMC	2.5%
% Passing 4.75mm	73.8
% Passing 75µm	11.4
Lab Class: Not acceptable as Granular A Base Material	
Acceptable as Granular B Type I Subbase Material	

Sample AS2

FMC	5.4%
% Passing 4.75mm	78.3
% Passing 75µm	22.7
Lab Class: Not acceptable as Granular B Type I Subbase Material	

Sample AS3

FMC	38.3%
% Passing 4.75mm	97.7
% Passing 75µm	65.1
% Passing 5µm	27.0
Lab Class:	LSFH

**2+650, 1.5 m Lt C/L, (MID)** **Core# 3**

0 - 45 Asph

**2+650, 1.8 m Lt C/L, (MID)** **BH# 14**

0 - 45	Asph	
45 - 460	Gry Sa and Gr, Moist	AS1
460 - 1.5	Br Sa Si, Moist	AS2

**2+850, 1.7 m Rt C/L, (MID)** **BH# 15**

0 - 70	Asph	
70 - 510	Gry Sa and Gr, Moist	AS1
510 - 1.5	Br Cl Si, Tr Sa, Moist	AS2

**3+050, 1.6 m Lt C/L, (MID)** **BH# 16**

0 - 75	Asph	
75 - 560	Br Sa and Gr, Moist	AS1
560 - 1.5	Br Sa Si, Moist	AS2

Sample AS1

FMC	4.5%
-----	------

Sample AS2

FMC	16.6%
-----	-------

**3+250, 2.0 m Rt C/L, (MID)** **BH# 17**

0 - 75	Asph	
75 - 405	Br Sa and Gr, Moist	AS1
405 - 1.5	Br Sa Si, Tr Cl, Moist	AS2

**3+450, 1.6 m Lt C/L, (MID)** **BH# 18**

Geotechnical Investigation Report Improvements to  
Regional Road Corridor Bounded by Winston Churchill Blvd., Bush St., Old Main St., Mississauga Rd., Olde Base Line Rd.  
Wellington, Ontario  
Regional Municipality of Peel  
Peel Project 11-4360

0 - 40	Asph		760 - 1.5	Br Cl Si, Tr Sa, Moist	AS3
40 - 355	Br Sa and Gr, Moist	AS1			
355 - 610	Br Si Sa, Tr Gr, Moist	AS2	<b>4+250, 1.6 m Lt C/L, (MID)</b>	<b>BH# 22</b>	
610 - 1.5	Br Sa Si, Tr Cl, Moist	AS3	0 - 15	Asph	
<b>3+650, 2.1 m Rt C/L, (MID)</b>		<b>BH# 19</b>	15 - 255	Br Sa and Gr, Moist	AS1
0 - 25	Asph		255 - 760	Br Gr Sa, Moist	AS2
25 - 255	Br Sa and Gr, Moist	AS1	760 - 1.5	Br Si Sa, Tr Gr, Moist	AS3
255 - 1.5	Br Si Sa, Some Gr, Moist	AS2	<u>Sample AS1</u>		
			FMC	3.1%	
<u>Sample AS1</u>			<u>Sample AS2</u>		
FMC	3.1%		FMC	2.9%	
<u>Sample AS2</u>			<u>Sample AS3</u>		
FMC	5.8%		FMC	6.1%	
<b>3+650, 2.1 m Rt C/L, (MID)</b>		<b>Core# 4</b>	<b>4+450, 2.1 m Rt C/L, (MID)</b>	<b>BH# 23</b>	
0 - 25	Asph		0 - 60	Asph	
			60 - 760	Br Sa Gr Some Si, Moist	AS1
			760 - 1.5	Br Si Sa, Tr Cl, Wet	AS2
<b>3+850, 1.8 m Lt C/L, (MID)</b>		<b>BH# 20</b>	<u>Sample AS1</u>		
0 - 50	Asph		FMC	3.0%	
50 - 460	Br Sa and Gr, Moist	AS1	% Passing 4.75mm	53.7	
460 - 1.5	Br Si Sa, Tr Gr, Moist	AS2	% Passing 75µm	15.3	
<b>4+050, 1.9 m Rt C/L, (MID)</b>		<b>BH# 21</b>	Lab Class: Not acceptable as Granular A Base Material		
0 - 45	Asph		Not acceptable as Granular B Type I Subbase		
45 - 460	Br Sa and Gr, Moist	AS1	Material		
460 - 760	Br Si Sa, Tr Gr, Moist	AS2			

<u>Sample AS2</u>				280 - 600	Br Sa and Gr, Moist	AS2
FMC	12.4%			600 - 1.2	Gry/Br Sa and Gr, Moist	AS3
				1.2 - 1.5	Gry/Br Sa and Gr, Tr Si, Moist	AS4
<b>4+650, 1.1 m Lt C/L, (MID)</b>			<b>Core# 5</b>			
0 - 15	Asph			<u>Sample AS1</u>		
				FMC	2.2%	
<b>4+650, 2.0 m Lt C/L, (MID)</b>			<b>BH# 24</b>			
0 - 15	Asph			<u>Sample AS2</u>		
15 - 205	Br Sa and Gr, Moist	AS1		FMC	4.5%	
205 - 760	Br Sa and Gr, Tr Si, Moist	AS2				
760	NFP Probable Rock			<u>Sample AS3</u>		
				FMC	3.9%	
<b>4+790, 4.1 m Rt C/L, (Sh)</b>			<b>BH# 25A</b>			
0 - 3.2	Br/Gry Sa and Gr, Moist			<u>Sample AS4</u>		
	(N= 69, 30, 11, 24 Very Dense to Compact)	SS1-SS4		FMC	4.8%	
3.2 - 3.8	Br Org M, Moist			<b>5+050, 1.9 m Lt C/L, (MID)</b>	<b>BH# 26</b>	
	(Decomposed Wood)			0 - 100	Asph	
	(N= 6 Firm)	SS5		100 - 405	Gry Sa and Gr, Moist	AS1
3.8 - 4.6	Gry Si Sa, Wet			405 - 760	Br Si Sa, Tr Gr, Moist	AS2
	(N= 7 Loose)	SS6		760 - 1.5	Sa Si, With Cl, Tr Gr, Moist	AS3
4.6 - 6.7	Gry Sa and Gr, Wet			<u>Sample AS3</u>		
	(N= 11, 43, 51 Compact to Very Dense)	SS7-SS9		% Passing 4.75mm	92.5	
<b>4+790, 2.1 m Rt C/L, (MID)</b>			<b>BH# 25</b>	% Passing 75µm	62.6	
0 - 50	Asph			% Passing 5µm	27.0	
50 - 280	Gry Sa and Gr, Moist	AS1		Lab Class:	LSFH	
	(Probable Recycled Asphalt)			<b>5+250, 1.3 m Rt C/L, (MID)</b>	<b>BH# 27</b>	



0	-	100	Asph	
100	-	610	Br Sa and Gr, Moist	AS1
610	-	1.5	Br Sa and Gr, Tr Si, Moist	AS2

**5+450, 1.5 m Lt C/L, (MID)**

**BH# 28**

0	-	45	Asph	
45	-	460	Br Sa and Gr, Moist	AS1
460	-	1.5	Br Si Sa, Some Gr, Moist	AS2

**Explanation of Terms Used**

Rt = Right

Lt = Left

Sh = Shoulder

Mid = Midlane

LSFH = Low Susceptibility Frost Heaving

MSFH = Moderate Susceptibility Frost Heaving

HSFH = High Susceptibility Frost Heaving

FMC = Field Moisture Content

NFP = No Further Progress

C/L = Centreline

SS = Split Spoon

AS = Auger Sample

Sample AS1

FMC 3.8%

Sample AS2

FMC 6.6%

**5+650, 1.8 m Rt C/L, (MID)**

**BH# 29**

0	-	80	Asph	
80	-	610	Br Sa and Gr, Moist	AS1
610	-	1.5	Br Gr Sa, Tr Si, Moist	AS2

**5+650, 1.9 m Rt C/L, (MID)**

**Core# 6**

0 - 80 Asph

**5+850, 1.8 m Lt C/L, (MID)**

**BH# 30**

0	-	40	Asph	
40	-	205	Br Sa and Gr, Moist	AS1
205	-	1.5	Br Sa, Moist	AS2

**Olde Base Line Road**

**Note:** Offsets are measured from centerline (C/L) of existing Olde Base Line Rd. Station 0+000 is at the intersection of Olde Base Line Rd and Winston Churchill Blvd. Stations increase from a west to east direction.

0 - 120	Asph	
120 - 350	Br Sa and Gr, Moist	AS1
350 - 1.2	Br Sa, Some Gr, Moist	AS2
1.2	NFP Probable Rock	

Sample AS1

FMC	3.5%
-----	------

Sample AS2

FMC	5.0%
-----	------

**0+050, 1.7 m Rt C/L, (MID)**

**BH# 1**

0 - 200	Asph	
200 - 380	Br Gr Sa With Si, Moist	AS1
380 - 1.5	Br Si Sa, Some Gr, Moist	AS2

Sample AS1

FMC	3.3%
% Passing 4.75mm	69.5
% Passing 75µm	21.6
Lab Class: Not acceptable as Granular A Base material	
Not acceptable as Granular B Type I Subbase Material	

Sample AS2

FMC	8.6%
-----	------

**0+250, 2.0 m Lt C/L, (MID)**

**BH# 2**

0 - 190	Asph	
190 - 850	Br Sa and Gr, Moist	AS1
850 - 1.2	Br Cl Si, Some Sa, Moist	AS2
1.2 NF	P Probable Rock	

**0+450, 2.3 m Rt C/L, (MID)**

**BH# 3**

**0+455, 2.4 m Rt C/L, (MID)**

**Core# 1**

0 - 120	Asph
---------	------

**0+650, 2.1 m Lt C/L, (MID)**

**BH# 4**

0 - 140	Asph	
140 - 270	Br Sa and Gr, Moist	AS1
270 - 1.5	Br Si Sa, Some Gr, Moist	AS2

Sample AS1

FMC	4.0%
-----	------

Sample AS2

FMC	5.1%
-----	------

**0+750, 4.1 m Rt C/L, (Sh)**

**BH# H3**

0 - 610	Br Sa and Gr, Moist (N= 13 Compact)	SS1
610 - 3.0	Br Cl Si, Moist	

	(N= 4, 8, 29 Firm)	SS2-SS4	890 - 1.5	Br Sa and Gr, Tr Cob, Moist	AS3
	Note: N=29 @ SS4 due to rock in spoon				
3.0 - 3.5	Br Sa Si, Some Cl, Tr Gr, Moist to Wet		<b>1+250, 1.8 m Rt C/L, (MID)</b>		<b>BH# 7</b>
	(N= 55 Very Dense)	SS5	0 - 85	Asph	
3.5	NFP Probable Rock		85 - 650	Br Sa With Gr Some Si, Moist	AS1
			650 - 1.0	Br Si With Sa and Cl Tr Gr, Moist	AS2
			1.0 - 1.5	Br Cl Si, Some Gr, Moist	AS3
	<b>0+850, 1.6 m Rt C/L, (MID)</b>	<b>BH# 5</b>			
0 - 40	Asph		<u>Sample AS1</u>		
40 - 580	Br Sa and Gr, Moist	AS1	FMC	2.9%	
580 - 1.5	Br Sa, Some Gr, Moist	AS2	% Passing 4.75mm	74.7	
			% Passing 75µm	17.0	
			Lab Class: Not acceptable as Granular A Base material		
			Not acceptable as Granular B Type I Subbase Material		
	<u>Sample AS1</u>				
FMC	4.5%				
	<u>Sample AS2</u>		<u>Sample AS2</u>		
FMC	4.5%		FMC	17.8%	
	<b>0+950, 4.2 m Lt C/L, (Sh)</b>	<b>BH# H2</b>	% Passing 4.75mm	96.3	
0 - 1.7	Br Sa and Gr, Moist		% Passing 75µm	71.7	
	(N= 22, 11 Compact)	SS1-SS2	% Passing 5µm	33.0	
1.7 - 3.0	Br/Blk/Red, Peat, Moist		Lab Class: LSFH		
	(N= 4, 3 Soft)	SS3-SS4			
	NFP Probable Rock		<b>1+400, 4.0 m Lt C/L, (Sh)</b>		<b>BH# H1</b>
			0 - 1.1	Br Sa and Gr, Moist	
				(N= 17, 13 Compact)	SS1-SS2
<b>1+050, 1.8 m Lt C/L, (MID)</b>		<b>BH# 6</b>	1.1 - 1.5	Br/Blk, Sa Si, Some Peat, Moist	
0 - 165	Asph		1.5 - 2.3	Br Sa and Gr, Moist	
165 - 390	Br Sa and Gr, Moist	AS1		(N= 9 Loose)	SS3
390 - 890	Br Si Sa, Some Gr, Moist	AS2			

2.3 - 3.8	Br/Red, Sa Si, Tr Cl, Moist (N= 9, 37 Loose to Dense)	SS4-SS5	<b>1+850, 1.5 m Lt C/L, (MID)</b>	<b>BH# 10</b>
			0 - 130	Asph
3.8 - 3.9	Gry Limestone (N= 50/8cm Hard)	SS6	130 - 380	Br Sa and Gr, Moist AS1
			380 - 880	Br/Red Sa Si, Some Gr, Moist
			880 - 1.5	Br/Red Cl Si, Moist

**1+450, 1.8 m Lt C/L, (MID) BH# 8**

0 - 105	Asph	
105 - 900	Br Sa and Gr, Moist	AS1
900 - 1.5	Gry Cl Si, Some Sa, Moist	AS2

Sample AS1

FMC 5.3%

Sample AS2

FMC 23.4%

**1+450, 1.5 m Lt C/L, (MID) Core# 2**

0 - 105	Asph	
110 - 540	Br Sa and Gr, Moist	AS1
540 - 1.5	Br Cl Si, Moist	AS2

**1+650, 1.6 m Rt C/L, (MID) BH# 9**

0 - 110	Asph	
110 - 540	Br Sa and Gr, Moist	AS1
540 - 1.5	Br Cl Si, Moist	AS2

Sample AS1

FMC 3.2%

Sample AS2

FMC 18.5%

**2+050, 1.8 m Rt C/L, (MID) BH# 11**

0 - 55	Asph	
55 - 620	Br Sa and Gr Some Si, Moist	AS1
620 - 1.1	Br Sa and Gr Some Si, Moist	AS2
1.1 NF	P Probable Rock	

Sample AS1

FMC 3.7%  
% Passing 4.75mm 52.8  
% Passing 75µm 13.0

Lab Class: Not acceptable as Granular A Base material  
Marginally acceptable as Granular B Type I Subbase Material

Sample AS2

FMC 3.4%  
% Passing 4.75mm 56.5  
% Passing 75µm 16.2

Lab Class: Not acceptable as Granular B Type I Subbase Material

**2+250, 1.4 m Lt C/L, (MID) BH# 12**

0 - 60	Asph	
60 - 320	Br Sa and Gr, Moist	AS1
320 - 1.5	Br Gr Sa, Moist	AS2

760 - 1.5 Dk Br Si Sa, Some Gr, Moist AS2

Sample AS1

FMC 3.6%

Sample AS2

FMC 7.6%

**2+450, 2.2 m Rt C/L, (MID)**

**BH# 13**

0 - 140 Asph  
140 - 530 Br Sa and Gr, Moist AS1  
530 - 1.2 Br Si With Sa and Cl Tr Gr, Moist AS2  
1.2 NF P Probable Rock

Sample AS1

FMC 3.1%

Sample AS2

FMC 20.4%  
% Passing 4.75mm 98.7  
% Passing 75µm 79.6  
% Passing 5µm 32.0  
Lab Class: MSFH

**2+450, 2.7 m Rt C/L, (MID)**

**Core# 3**

0 - 140 Asph

**2+650, 1.7 m Lt C/L, (MID)**

**BH# 14**

0 - 70 Asph  
70 - 760 Br Sa and Gr, Moist AS1

**Explanation of Terms Used**

Rt = Right

Lt = Left

Sh = Shoulder

Mid = Midlane

LSFH = Low Susceptibility Frost Heaving

MSFH = Moderate Susceptibility Frost Heaving

HSFH = High Susceptibility Frost Heaving

FMC = Field Moisture Content

NFP = No Further Progress

C/L = Centreline

SS = Split Spoon

AS = Auger Sample

Geotechnical Investigation Report Improvements to  
Regional Road Corridor Bounded by Winston Churchill Blvd., Bush St., Old Main St., Mississauga Rd., Olde Base Line Rd.  
Wellington, Ontario  
Regional Municipality of Peel  
Peel Project 11-4360

# Appendix B

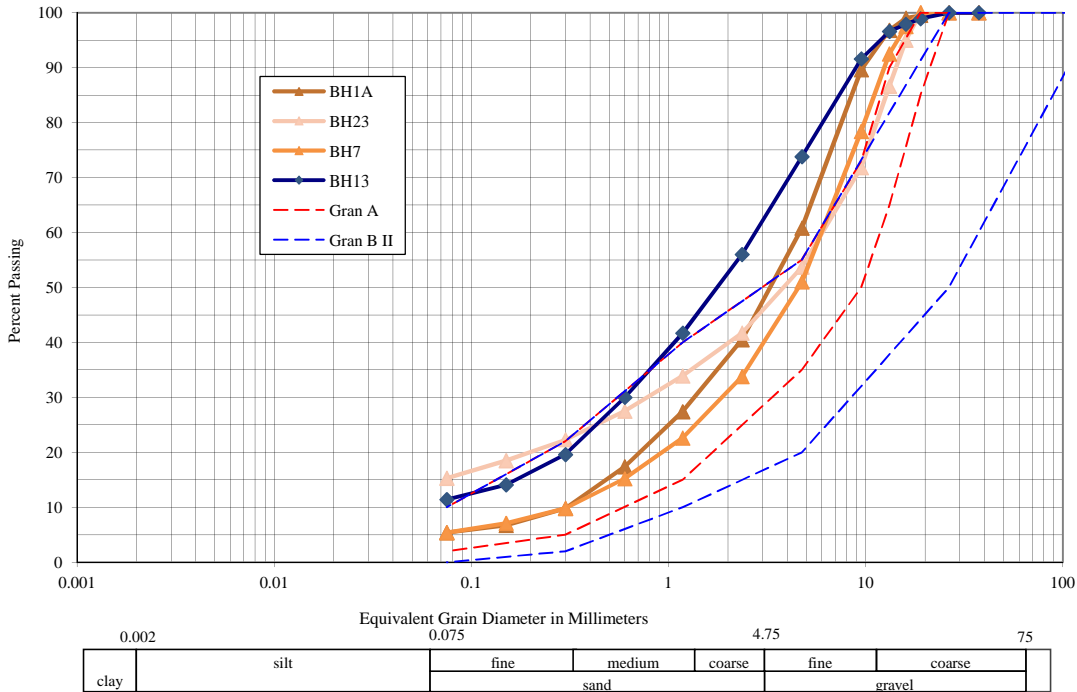
## **Geotechnical Laboratory Testing Results**

# Grain Size Analysis



**STATION:** Multiple Locations  
**SAMPLE NUMBER:** Granular Base Material  
**PROJECT NUMBER:** GEOTETOB21649AA  
**PROJECT:** Winston Churchill Blvd  
**CLIENT:** HDR c/o Peel Region  
**CONTRACTOR:**  
**PROJECT SITE:** Winston Churchill Blvd  
**SAMPLED BY:** Lorne G  
**DATE SAMPLED:** December 18, 2012  
**SUPPLIER:**  
**SAMPLE LOCATION:** Multiple Locations  
**DESCRIPTION:**  
**DATE TESTED:** February 19, 2013  
**SPECIFICATION:** OPSS Granular A  
**COMMENTS:**

SIEVE SIZE	SPECIFICATIONS	BH1A	BH7	BH13	BH23
		PERCENT PASSING	PERCENT PASSING	PERCENT PASSING	PERCENT PASSING
37.5 mm		100.0	100.0	100	100
26.5 mm	100	100.0	100.0	100	100
19.0 mm	85-100	99.5	100.0	98.9	100
16.0 mm		99.0	97.5	97.9	95
13.2 mm	65-90	96.8	92.5	96.6	86.6
9.5 mm	50-73	89.6	78.4	91.6	71.8
4.75 mm	35-55	60.8	51.0	73.8	53.7
2.36 mm		40.5	33.8	56	41.7
1.18 mm	15-40	27.4	22.6	41.7	33.9
600 µm		17.4	15.2	30	27.5
300 µm	5-22	9.8	9.8	19.6	22.3
150 µm		6.7	7.1	14.1	18.5
75 µm	2-10	5.4	5.4	11.4	15.3



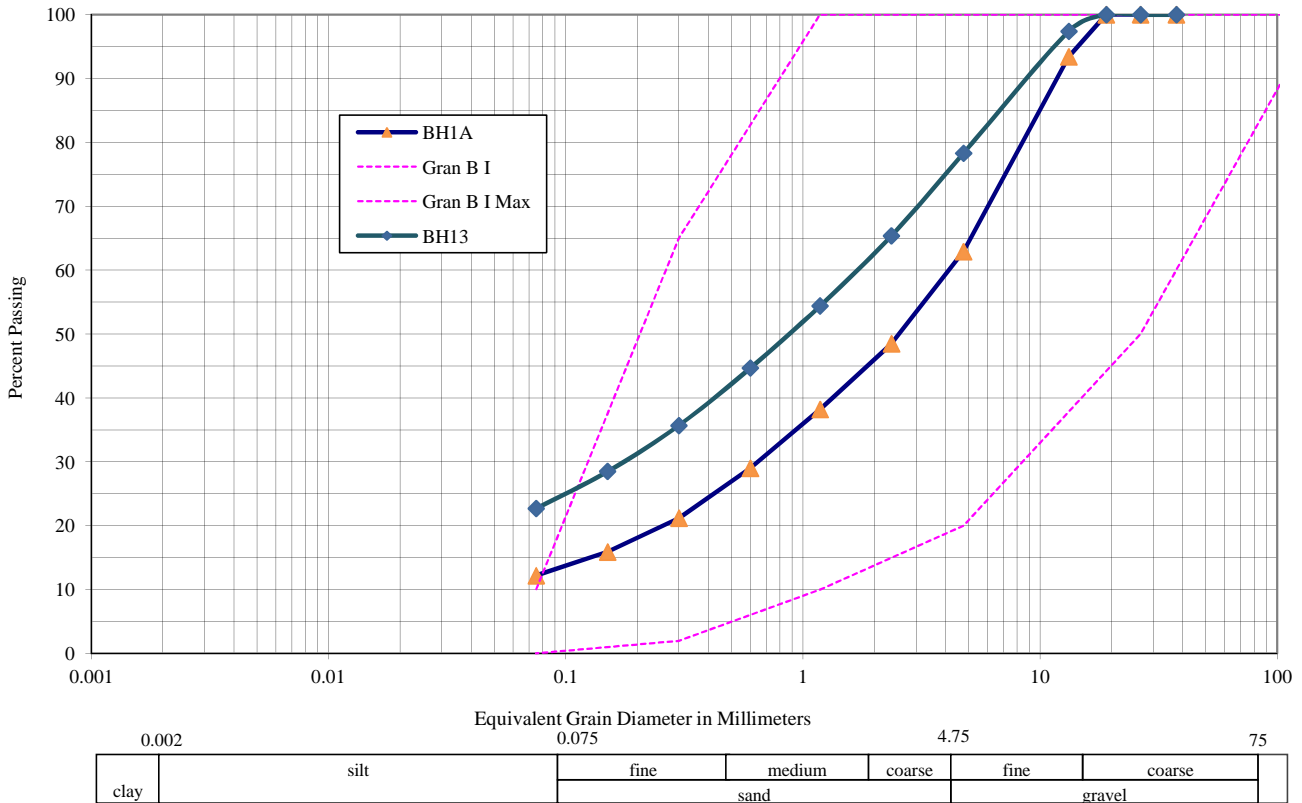
# Grain Size Analysis



**STATION:** 0-050 BH 1A  
**SAMPLE NUMBER:** AS2  
**PROJECT NUMBER:** GEOTETOB21649AA  
**PROJECT:**  
**CLIENT:** HDR  
**CONTRACTOR:**  
**PROJECT SITE:** Winston Churchill Blvd, from 50m south of Olde Baseline Rd to Bush St  
**SAMPLED BY:** Lorne G  
**DATE SAMPLED:** December 18, 2012  
**SUPPLIER:**  
**SAMPLE LOCATION:** Winston Churchill Blvd, 1.9m Rt CL (Mid)  
**DESCRIPTION:** Gr Sa Some Si, from 650mm to 900mm  
**DATE TESTED:** February 19, 2013  
**SPECIFICATION:** Granular B Type I Subbase Material  
**COMMENTS:** Marginally acceptable as Granular B Type I Subbase Material

SIEVE SIZE	SPECIFICAT IONS	BH1A	BH13
		PERCENT PASSING	% Passing
37.5 mm		100.0	100
26.5 mm	50-100	100.0	100
19.0 mm		100.0	100
13.2 mm		93.4	97.4
4.75 mm	20-100	62.9	78.3
2.36 mm		48.5	65.4
1.18 mm	10-100	38.2	54.4
600 µm		29.0	44.7
300 µm	2-65	21.2	35.7
150 µm		15.9	28.5
75 µm	0-10	12.2	22.7

Lt = Left; Rt = Right; CL = Centerline; EP = Edge of Pavement; Mid = Mid-Lane; Sh=Shoulder





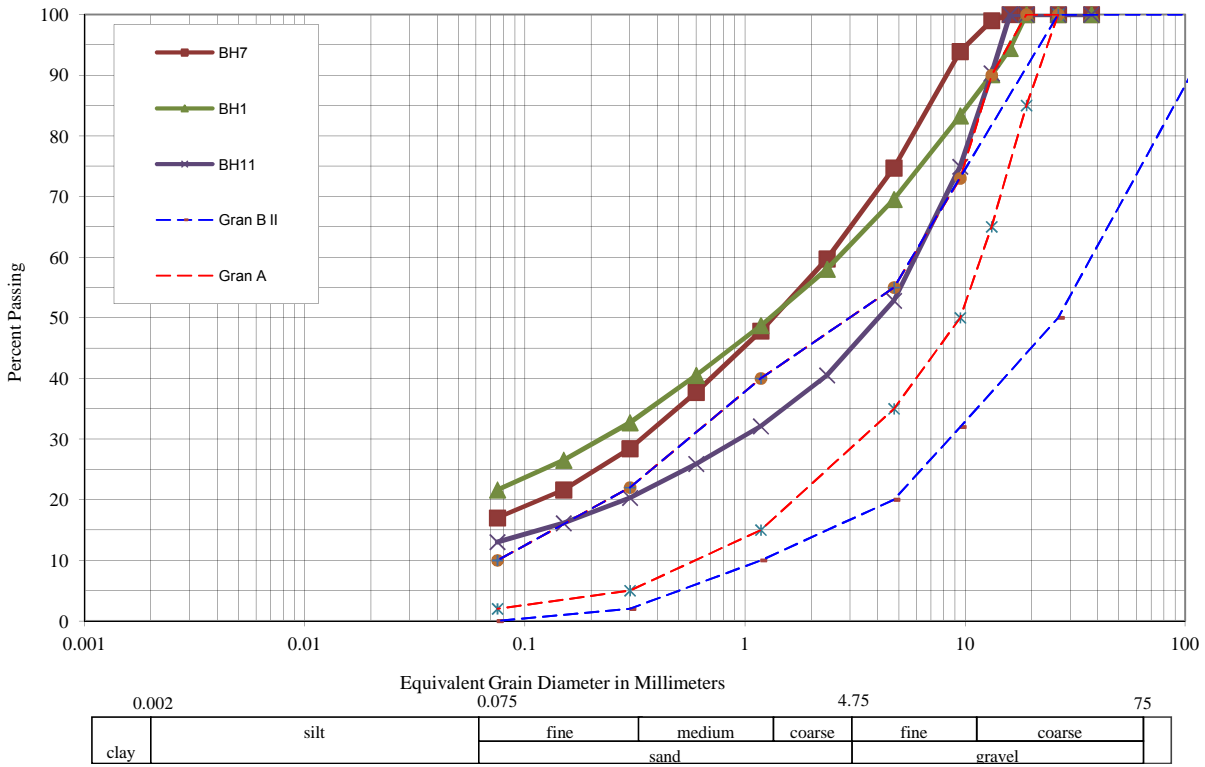
# Grain Size Analysis



**STATION:** 0+050 BH 1  
**SAMPLE NUMBER:** AS1  
**PROJECT NUMBER:** GEOTETOB21649AA  
**PROJECT:**  
**CLIENT:** HDR  
**CONTRACTOR:**  
**PROJECT SITE:** Olde Baseline Rd, from Winston Churchill Blvd to Mississauga Rd  
**SAMPLED BY:** Lorne G  
**DATE SAMPLED:** December 17, 2012  
**SUPPLIER:**  
**SAMPLE LOCATION:** Olde Baseline Rd, 1.7m Rt CL (Mid)  
**DESCRIPTION:** Gr Sa With Si, from 200mm to 380mm  
**DATE TESTED:** February 20, 2013  
**SPECIFICATION:** Granular A Base Material  
**COMMENTS:** Not acceptable as Granular A Base Material  
 Not acceptable as Granular B Type I Subbase Material

SIEVE SIZE	SPECIFICATIONS	BH1	BH7	BH11
		PERCENT PASSING	PERCENT PASSING	PERCENT PASSING
37.5 mm		100.0	100	100
26.5 mm	100	100.0	100	100
19.0 mm	85-100	100.0	100	100
16.0 mm		94.4	100	100
13.2 mm	65-90	90.1	99	90.3
9.5 mm	50-73	83.3	93.9	74.9
4.75 mm	35-55	69.5	74.7	52.8
2.36 mm		58.0	59.7	40.5
1.18 mm	15-40	48.7	47.8	32.1
600 µm		40.5	37.7	25.9
300 µm	5-22	32.7	28.4	20.3
150 µm		26.5	21.6	16.1
75 µm	2-10	21.6	17	13

Lt = Left; Rt = Right; CL = Centerline; EP = Edge of Pavement; Mid = Mid-Lane; Sh=Shoulder



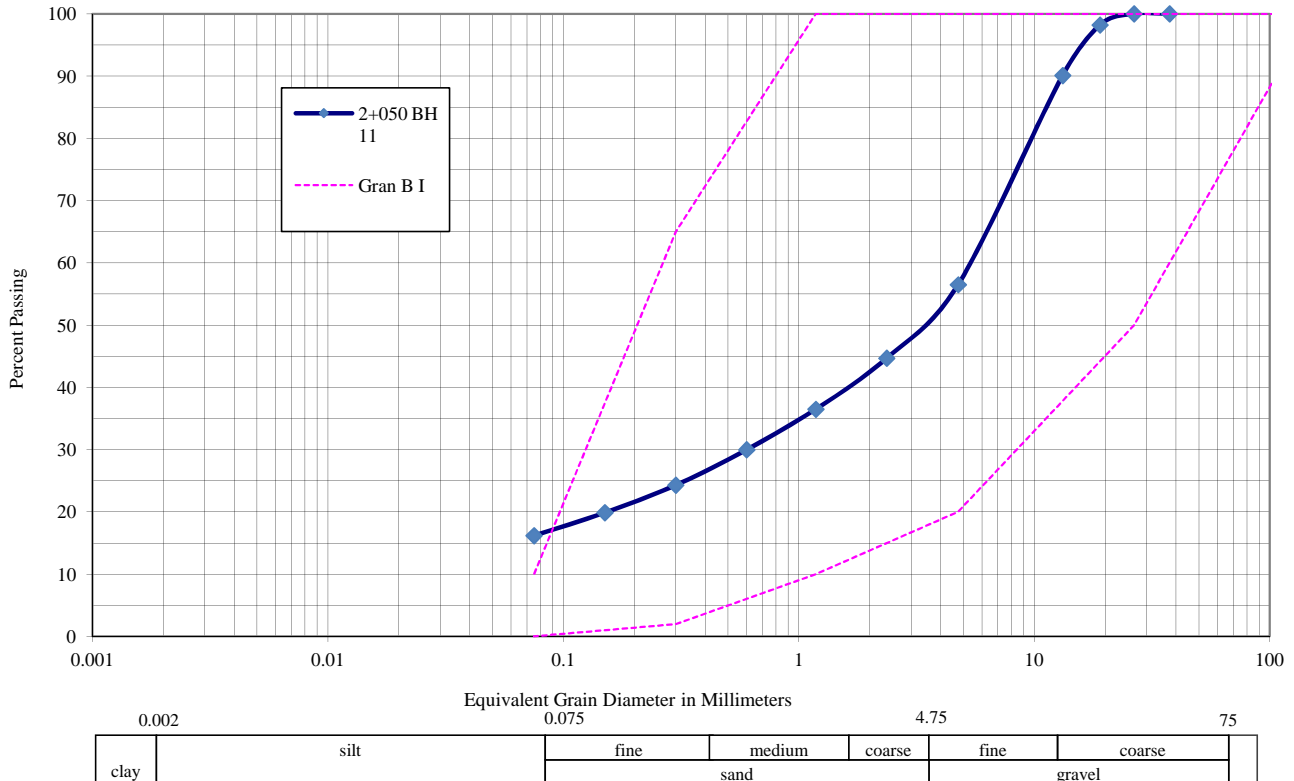
# Grain Size Analysis



**STATION:** 2+050 BH 11  
**SAMPLE NUMBER:** AS2  
**PROJECT NUMBER:** GEOTETOB21649AA  
**PROJECT:**  
**CLIENT:** HDR  
**CONTRACTOR:**  
**PROJECT SITE:** Olde Baseline Rd, from Winston Churchill Blvd to Mississauga Rd  
**SAMPLED BY:** Lorne G  
**DATE SAMPLED:** December 18, 2012  
**SUPPLIER:**  
**SAMPLE LOCATION:** Olde Baseline Rd, 1.8m Rt CL (Mid)  
**DESCRIPTION:** Sa and Gr Some Si, from 620mm to 1.1m  
**DATE TESTED:** February 20, 2013  
**SPECIFICATION:** Granular B Type I Subbase Material  
**COMMENTS:** Not acceptable as Granular B Type I Subbase Material

SIEVE SIZE	PERCENT PASSING	SPECIFICATIONS
37.5 mm	100.0	
26.5 mm	100.0	50-100
19.0 mm	98.2	
13.2 mm	90.1	
4.75 mm	56.5	20-100
2.36 mm	44.7	
1.18 mm	36.5	10-100
600 µm	30.0	
300 µm	24.3	2-65
150 µm	19.9	
75 µm	16.2	0-10

Lt = Left; Rt = Right; CL = Centerline; EP = Edge of Pavement; Mid = Mid-Lane; Sh=Shoulder



0.002	silt	0.075	4.75	75
clay		fine	medium	coarse
		sand		fine
				coarse
				gravel

Geotechnical Investigation Report Improvements to  
Regional Road Corridor Bounded by Winston Churchill Blvd., Bush St., Old Main St., Mississauga Rd., Olde Base Line Rd.  
Wellington, Ontario  
Regional Municipality of Peel  
Peel Project 11-4360

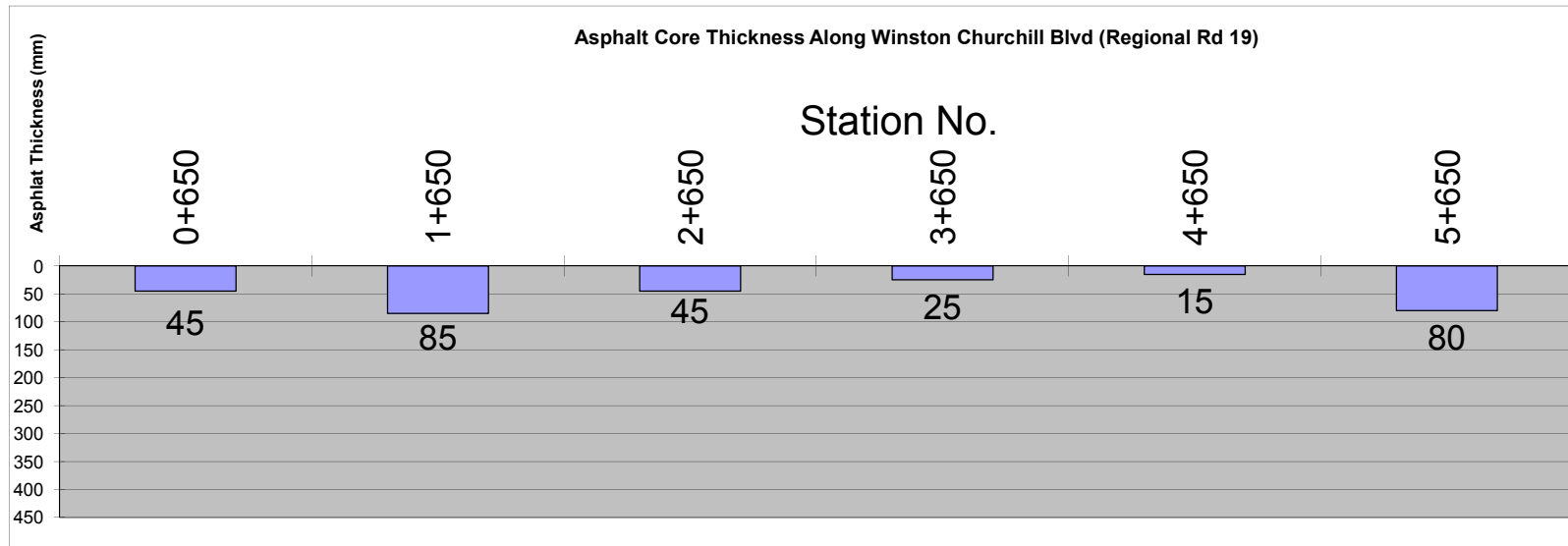
# Appendix C

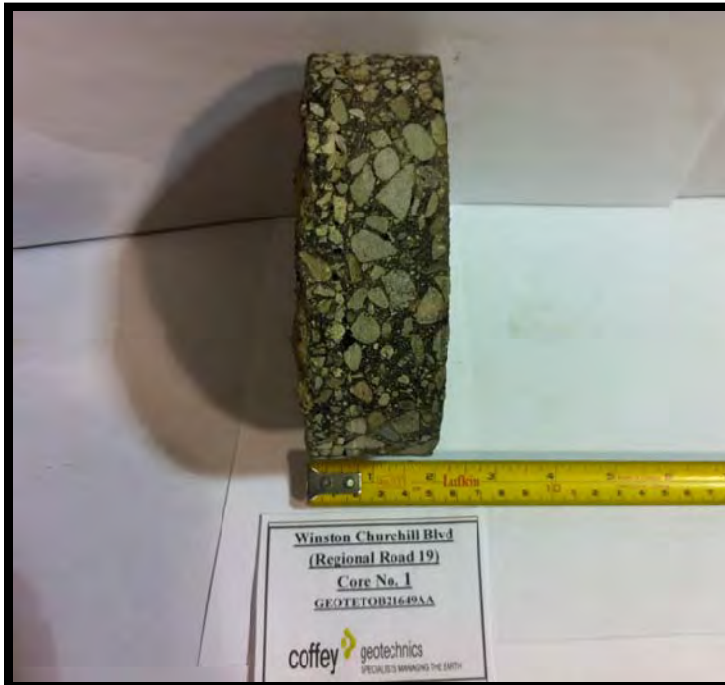
## **Pavement Core Logs and Core Photographs**

**CORE LOGS**

COFFEY PROJECT NUMBER: TRANETOB21649AA (Winston Churchill Blvd from Olde Baseline Rd northward towards Bush St)  
Date of Coring: Dec 17th 2012 to Dec 20th 2012

Station	Offset from Hwy C/L (m)	Direction (Lt/Rt)	Core No.	Total Asphalt Thickness (mm)	Asphalt Mix Types and Thickness (mm)	Remarks
Winston Churchill Blvd (Regional Road 19)						
0+650	2.20	Lt	1	45	Top 30 HL3, 15 HL2 Bottom	
1+650	1.80	Rt	2	85	Top 55 HL3, 30 HL4 Bottom	
2+650	1.50	Lt	3	45	45 HL4	
3+650	2.10	Rt	4	25	25 HL4	
4+650	1.10	Lt	5	15	15 HL4	
5+650	1.90	Rt	6	80	Top 55 HL3, 25 HL4 Bottom	
Count				6		
Minimum				15		
Maximum				85		
Mean				49.2		





**Photograph No. (1)**

**Core No.:** 1  
**Station:** 0+650  
**Offset:** 2.2 m Lt C/L  
**Total Thickness:** 45 mm  
**Asphalt Mix Types**  
**& Thickness**  
Top 30mm HL3, 15mm HL2  
Bottom



**Photograph No. (2)**

**Core No.:** 2  
**Station:** 1+650  
**Offset:** 1.8 m Rt C/L  
**Total Thickness:** 85 mm  
**Asphalt Mix Types**  
**& Thickness**  
Top 55mm HL3, 30mm HL4  
Bottom



**Photograph No. (3)**

**Core No.:** 3  
**Station:** 2+650  
**Offset:** 1.5 m Lt C/L  
**Total Thickness:** 45 mm  
**Asphalt Mix Types**  
**& Thickness**  
45mm HL4



**Photograph No. (4)**

**Core No.:** 4  
**Station:** 3+650  
**Offset:** 2.1 m Rt C/L  
**Total Thickness:** 25 mm  
**Asphalt Mix Types**  
**& Thickness**  
25mm HL4



**Photograph No. (5)**

**Core No.:** 5  
**Station:** 4+650  
**Offset:** 1.1 m Lt C/L  
**Total Thickness:** 15 mm  
**Asphalt Mix Types**  
**& Thickness**  
15mm HL4



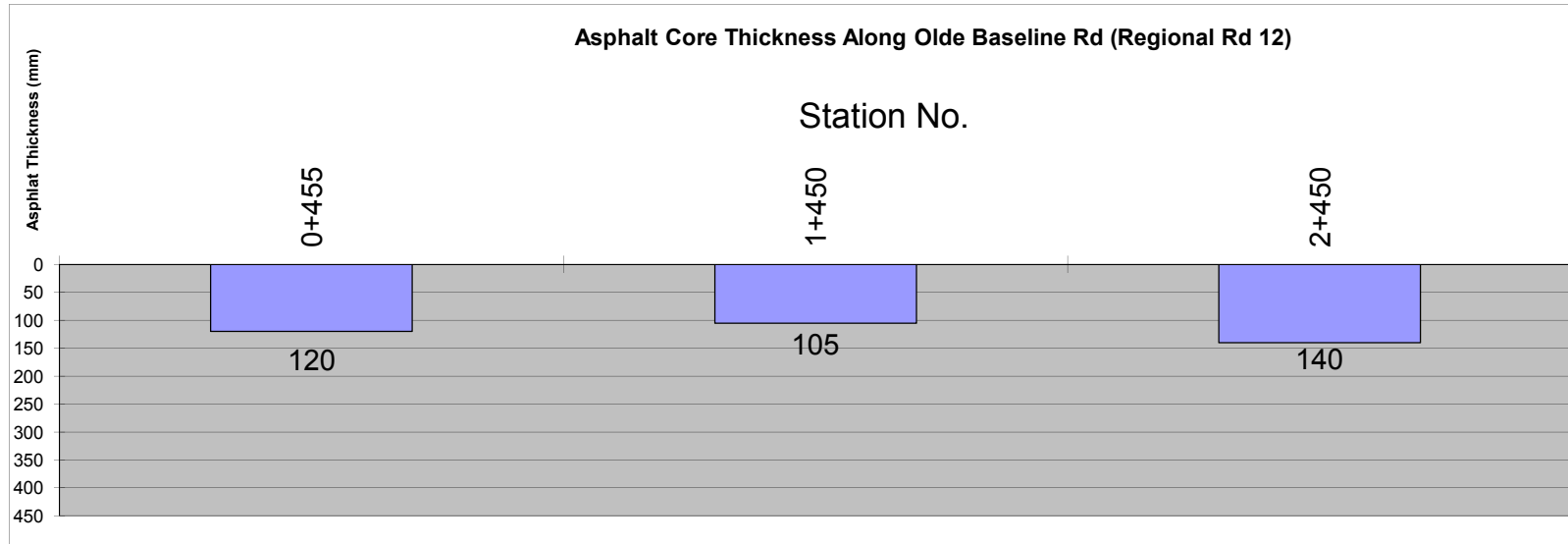
**Photograph No. (6)**

**Core No.:** 6  
**Station:** 5+650  
**Offset:** 1.9 m Rt C/L  
**Total Thickness:** 80 mm  
**Asphalt Mix Types**  
**& Thickness**  
Top 55mm HL3, 25mm HL4  
Bottom

CORE LOGS

COFFEY PROJECT NUMBER: TRANETOB21649AA (Olde Baseline Rd from Winston Churchill Blvd eastward towards Mississauga Rd)  
Date of Coring: Dec 17th 2012 to Dec 20th 2012

Station	Offset from Hwy C/L (m)	Direction (Lt/Rt)	Core No.	Total Asphalt Thickness (mm)	Asphalt Mix Types and Thickness (mm)	Remarks
Olde Baseline Rd (Regional Road 12)						
0+455	2.40	Rt	1	120	Top 45 HL3, 45 HL3, 30 HL4 Bottom	Weak bonding between HL4 and HL3 layers
1+450	1.50	Lt	2	105	Top 60 HL3, 25 HL3, 20 HL4 Bottom	Weak bonding between layers
2+450	2.70	Rt	3	140	Top 55 HL3, 50 HL3, 35 HL4 Bottom	Weak bonding between layers
Count				3		
Minimum				105		
Maximum				140		
Mean				121.7		







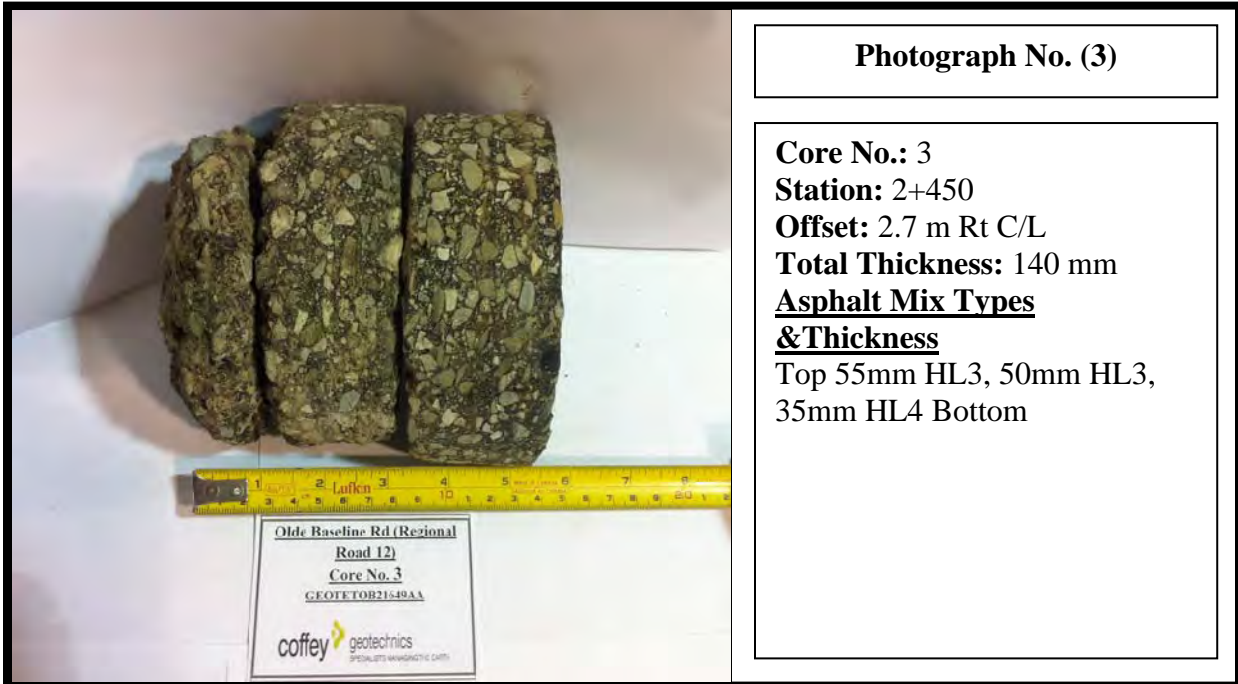
**Photograph No. (1)**

**Core No.:** 1  
**Station:** 0+455  
**Offset:** 2.4 m Rt C/L  
**Total Thickness:** 120 mm  
**Asphalt Mix Types & Thickness**  
Top 45mm HL3, 45mm HL3,  
30mm HL4 Bottom



**Photograph No. (2)**

**Core No.:** 2  
**Station:** 1+450  
**Offset:** 1.5 m Lt C/L  
**Total Thickness:** 105 mm  
**Asphalt Mix Types & Thickness**  
Top 60mm HL3, 25mm HL3,  
20mm HL4 Bottom



**Photograph No. (3)**

**Core No.:** 3  
**Station:** 2+450  
**Offset:** 2.7 m Rt C/L  
**Total Thickness:** 140 mm  
**Asphalt Mix Types**  
**& Thickness**  
Top 55mm HL3, 50mm HL3,  
35mm HL4 Bottom

Geotechnical Investigation Report Improvements to  
Regional Road Corridor Bounded by Winston Churchill Blvd., Bush St., Old Main St., Mississauga Rd., Olde Base Line Rd.  
Wellington, Ontario  
Regional Municipality of Peel  
Peel Project 11-4360

# Appendix D

## Important Information about your Coffey Report



## Important information about your Coffey Report

As a client of Coffey you should know that site subsurface conditions cause more construction problems than any other factor. These notes have been prepared by Coffey to help you interpret and understand the limitations of your report.

### **Your report is based on project specific criteria**

Your report has been developed on the basis of your unique project specific requirements as understood by Coffey and applies only to the site investigated. Project criteria typically include the general nature of the project; its size and configuration; the location of any structure on the site; other site improvements; the presence of underground utilities; and the additional risk imposed by scope-of-service limitations imposed by the client. Your report should not be used if there are any changes to the project without first asking Coffey to assess how factors that changed subsequent to the date of the report affect the report's recommendations. Coffey can not accept responsibility for problems that may occur due to changed factors if they are not consulted.

### **Subsurface conditions can change**

Subsurface conditions are created by natural processes and the activity of man. For example, water levels can vary with time, fill may be placed on a site and pollutants may migrate with time. Because a report is based on conditions which existed at the time of subsurface exploration, decisions should not be based on a report whose adequacy may have been affected by time. Consult Coffey to be advised how time may have impacted on the project.

### **Interpretation of factual data**

Site assessment identifies actual subsurface conditions only at those points where samples are taken and when they are taken.

Data derived from literature and external data source review, sampling and subsequent laboratory testing are interpreted by geologists, engineers or scientists to provide an opinion about overall site

conditions, their likely impact on proposed development and recommended actions. Actual conditions may differ from those inferred to exist, because no professional, no matter how qualified can reveal what is hidden by earth rock and time. The actual interface between materials may be far more gradual or abrupt than assumed based on the facts obtained. Nothing can be done to change the actual site conditions which exist, but steps can be taken to reduce the impact of unexpected conditions. For this reason, owners should retain the services of Coffey through the development stage, to identify variances, conduct additional tests if required, and recommend solutions to problems encountered on site.

### **Your report will only give preliminary recommendations**

Your report is based on the assumption that the site conditions as revealed through selective point sampling are indicative of actual conditions throughout an area. This assumption cannot be substantiated until project implementation has commenced and therefore your report recommendations can only be regarded as preliminary. Only Coffey, who prepared the report, is fully familiar with the background information needed to assess whether or not the report's recommendations are valid and whether or not changes should be considered as the project develops. If another party undertakes the implementation of the recommendations of this report there is a risk that the report will be misinterpreted and Coffey can not be held responsible for such misinterpretation.



### **Your report is prepared for specific purposes and persons**

To avoid the misuse of the information contained in your report it is recommended that you confer with Coffey before passing your report on to another party who may not be familiar with the background and the purpose of the report. Your report should not be applied to any project other than that originally specified at the time the report was issued.

### **Interpretation by other design professionals**

Costly problems can occur when other design professionals develop their plans based on misinterpretations of a report. To help avoid misinterpretations, retain Coffey to work with other project design professionals who are affected by the report. Have Coffey explain the report implications to design professionals affected by them and then review plans and specifications produced to see how they incorporated the report findings.

### **Data should not be separated from the report**

The report as a whole presents the findings of the site assessment and the report should not be copied in part or altered in any way.

Logs, figures, drawings, etc. are customarily included in our reports and are developed by scientists, engineers or geologists based on their interpretation of field logs (assembled by field personnel) and laboratory evaluation of field samples. These logs etc. should not under any circumstances be redrawn for inclusion in other documents or separated from the report in any way.

### **Geoenvironmental concerns are not at issue**

Your report is not likely to relate any findings, conclusions, or recommendations about the

potential for hazardous materials existing at the site unless specifically required to do so by the client. Specialist equipment, techniques, and personnel are used to perform geoenvironmental assessment.

Contamination can create major health, safety and environmental risks. If you have no information about the potential for your site to be contaminated or create an environmental hazard, you are advised to contact Coffey for information relating to geoenvironmental issues.

### **Rely on Coffey for additional assistance**

Coffey is familiar with a variety of techniques and approaches that can be used to help reduce risks for all parties to a project, from design to construction. It is common that not all approaches will be necessarily dealt with in your site assessment report due to concepts proposed at that time. As the project progresses through design towards construction, speak with Coffey to develop alternative approaches to problems that may be of genuine benefit both in time and cost.

### **Responsibility**

Reporting relies on interpretation of factual information based on judgement and opinion and has a level of uncertainty attached to it, which is far less exact than the design disciplines. This has often resulted in claims being lodged against consultants, which are unfounded. To help prevent this problem, a number of clauses have been developed for use in contracts, reports and other documents. Responsibility clauses do not transfer appropriate liabilities from Coffey to other parties but are included to identify where Coffey's responsibilities begin and end. Their use is intended to help all parties involved to recognise their individual responsibilities. Read all documents from Coffey closely and do not hesitate to ask any questions you may have.